



GRIGOL ROBAKIDZE  
UNIVERSITY



# EURASIAN MULTIDISCIPLINARY FORUM

PROCEEDINGS Vol. 3

**1<sup>st</sup> Eurasian Multidisciplinary Forum, EMF 2013**

*24-26 October 2013, Tbilisi, Georgia*

*(Forum`s place: GrigolRobakidze University, Tbilisi)*

**EMF, Tbilisi, 24-26 October 2013**

# **PROCEEDINGS**

***Vol. 3***

**1<sup>st</sup> Eurasian Multidisciplinary Forum, EMF 2013**  
***24-26 October 2013, Tbilisi, Georgia***  
***(Forum`s place: Grigol Robakidze University, Tbilisi)***

**European Scientific Institute, ESI (publishing)**

***Impressum***

Bibliographic information published by the National and University Library "St. Kliment Ohridski" in Skopje, Macedonia; detailed bibliographic data are available in the internet at <http://www.nubsk.edu.mk/>;

CIP - 3(062)

COBISS. MK-ID 95072522

Any brand names and product names mentioned in this book are subject to trademark, brand or patent protection and trademarks or registered trademarks of their respective holders.

The use of brand names, product names, common names, trade names, product descriptions etc. even without a particular marking in this works is in no way to be construed to mean that such names may be regarded as unrestricted in respect of trademark and brand protection legislation and could thus be used by anyone.

PROCEEDINGS: 1st Eurasian Multidisciplinary Forum, EMF 2013, 24-26 October 2013, Tbilisi, Georgia.

European Scientific Institute, ESI, 2013. - 3 vol. (465, 544, 149 p.) : ilustr. ; 28 cm

Kocani, Republic of Macedonia

Email: [contact@eujournal.org](mailto:contact@eujournal.org)

Printed in Republic of Macedonia

**ISBN 978-608-4642-12-1**

Copyright © 2013 by the authors, ESI and licensors

All rights reserved. 2013

# **PROCEEDINGS**

***Vol. 3***

**1<sup>st</sup> Eurasian Multidisciplinary Forum, EMF 2013**  
***24-26 October 2013, Tbilisi, Georgia***  
***(Forum`s place: Grigol Robakidze University, Tbilisi)***

# Table of Contents

<b>CRITICAL FACTORS IN MANAGING CUSTOMER-SUPPLIER RELATIONS.....</b>	<b>1</b>
<i>Satya Jaya Aparna Pasi</i>	
<b>MULTI-PORT ELECTRIC STIMULATION SYSTEM USING HIGH SPEED PROCESSORS.....</b>	<b>12</b>
<i>Lopez de la Fuente</i>	
<i>Martha Salome</i>	
<b>DETERMINING THE PREFERENCES OF A SOCIAL GROUP STATISTICALLY AND DYNAMICALLY.....</b>	<b>20</b>
<i>Kamal Taha</i>	
<b>PROPOSING A REAL TIME INTERNAL INTRUSION DETECTION SYSTEM TOWARDS A SECURED DEVELOPMENT OF E-GOVERNMENT WEB SITE.....</b>	<b>27</b>
<i>Al-Khanjari, Z.</i>	
<i>Alanee, A.</i>	
<i>Kraiem, N.</i>	
<i>Jamoussi, Y.</i>	
<b>IMPROVING THE CITIZEN EXPERIENCE IN THE USE OF MEXICAN GOVERNMENT WEBSITES.....</b>	<b>38</b>
<i>Marta Sylvia del Rio</i>	
<b>BUSINESS' PARTICIPANTS MOTIVATION IN OFFICIAL SURVEYS BY FUZZY LOGIC.....</b>	<b>42</b>
<i>Miroslav Hudec</i>	
<i>Vanessa Torres van Grinsven</i>	
<b>EXPERIMENTAL HYBRID SOLAR CONCENTRATOR UNIT SYSTEM FOR SANITARY WATER.....</b>	<b>53</b>
<i>Vitali, A.</i>	
<i>Modai, E.</i>	
<i>Jimenez Placer, G.</i>	
<i>Moron, I.</i>	
<i>Zambrano, Daniel</i>	
<b>POTENTIAL OF RAINWATER HARVESTING IN BUILDINGS TO REDUCE OVER EXTRACTION OF GROUNDWATER IN URBAN AREAS OF BANGLADESH.....</b>	<b>68</b>
<i>Maharam Dakua</i>	
<i>Fahmida Akhter</i>	
<i>Partha Protim Biswas</i>	
<i>Md. Latifur Rahman Siddique</i>	
<i>Reyad Morshed Shihab</i>	
<b>THE CVD VARIABLES METHOD FOR TAILORING HFCVD CARBON NANOTUBE MORPHOLOGY.....</b>	<b>75</b>
<i>Ashfaq Hussain</i>	

<b>A SURVEY OF ANT COLONY BASED ROUTING ALGORITHMS FOR MANET .....</b>	<b>82</b>
<i>Dharmendra Sutariya</i>	
<i>Pariza Kamboj</i>	
<b>ADDRESSING COMMUNITY BASED PROBLEMS: EXPLORING THE ROLE OF CBO THROUGH PARTICIPATORY APPROACH.....</b>	<b>92</b>
<i>Sadya Islam</i>	
<i>Antora M. Haque</i>	
<i>Mohammad T. H. Shubho</i>	
<i>Ishrat Islam</i>	
<i>Farzana Khatun</i>	
<i>Dipita Hossain</i>	
<b>CYCLIC BENDING OF VARIOUS GLASS FIBRES REINFORCED WITH POLYMER COMPOSITE ARCHITECTURES.....</b>	<b>105</b>
<i>Mihai Alin Pop</i>	
<i>Virgil Geamqñ</i>	
<i>Dana Luca Motoc</i>	
<i>Vlad Monescu</i>	
<i>Irinel Radomir</i>	
<b>EFFECT OF THICKNESS AND ANNEALING TEMPERATURE ON D.C. ELECTRICAL CONDUCTIVITY OF GaAs FILMS AND (C-V) CHARACTERIZATION OF GaAs/Ge HETEROJUNCTION.....</b>	<b>110</b>
<i>Nahida B. Hasan</i>	
<i>Maysoon F. Alias</i>	
<i>Raad M. Al-Haddad</i>	
<i>Huda B. Hasan</i>	
<b>NO REFERENCE IMAGE QUALITY ASSESSMENT DEPENDING ON YCbCr AND L*u*v*.....</b>	<b>119</b>
<i>Musa Kadhim Mohsin</i>	
<b>STUDY THE OPTICAL PROPERTIES OF POLYVINYLPIRROLIDONE (PVP) DOPED WITH KBr.....</b>	<b>132</b>
<i>Hussein Hakim</i>	
<i>Ahmed Hashim</i>	
<i>Ghaidaa Abdul-Hafidh</i>	
<i>Alyaa .H.A</i>	
<i>Saif Mohammed</i>	
<b>CONTRIBUTION TO OPTIMIZING THE PERFORMANCES OF ANAEROBIC REACTOR.....</b>	<b>138</b>
<i>Abid Abdelilah</i>	
<i>Jellal Jamal Eddine</i>	
<b>ASPECTS ABOUT THE PROPERTIES OF A BAINITIC DUAL-PHASE S.G. CAST IRON.....</b>	<b>149</b>
<i>Ioan Milosan</i>	
<b>TRIBOLOGICAL PROPERTIES OF THERMAL SPRAY COATINGS.....</b>	<b>154</b>
<i>Virgil Geaman</i>	
<i>Mihai Alin Pop</i>	
<i>Dana Luca Motoc</i>	
<i>Irinel Radomir</i>	

- ENERGY COST AND OPTIMIZATION OF A CLOSED CIRCUIT CRUSHING PLANT WITH A CENTRIFUGAL CRUSHER.....160**  
*Elias Stamboliadis*  
*Dimitris Stamboliadis*
- THEORETICAL AND PRACTICAL CONSIDERATIONS ON SOME OF THE DIFFUSION ASPECTS IN THE PRESENCE OF MECHANICAL VIBRATIONS.....169**  
*Stoicanescu Maria*
- SIMPLE REGRESSION MODELS FOR PREDICTING SOIL HYDROLYTIC ACIDITY....173**  
*Zdenko Loncaric*  
*Vlado Kovacevic*  
*Domagoj Rastija*  
*Krunoslav Karalic*  
*Brigita Popovic*  
*Vladimir Ivezic*  
*Zoran Semialjac*
- EXPERIMENTAL AND CALCULATION-BASED FORECASTING OF FUEL CONSUMPTION ON ZINC-BEARING SLAG PROCESSING UNIT BASED ON PHASE INVERSION REACTOR.....180**  
*B. Dikhanbayev*  
*K. Baubekov*  
*A. Dikhanbayev*
- ECONOMICAL ASPECTS OF DILUTED HF SOLUTIONS ON THE ANTIREFLECTIONS PROPERTIES OF THE FLOAT GLASS SURFACES.....186**  
*Jan Wasylak*  
*Joanna Zontek-Wilkowska*
- MITIGATION OF METALLIC ION CONCENTRATIONS IN THE ENVIRONMENT USING MICROORGANISMS.....192**  
*Vasile-Sorin Manoiu*  
*Valentina-Mariana Manoiu*  
*Manuel Drugulescu*  
*Ovidiu Popa*
- INFLUENCE OF AIR-DECK LENGTH ON FRAGMENTATION IN QUARRY BLASTING.....200**  
*Suttitthep Rommayawes*  
*Chewchan Leelasukseree*  
*Pirat Jaroonpattanapong*
- TRACE METALS CHARACTERISATION IN ENVIRONMENTAL MEDIA: A CASE STUDY OF CEMENT PRODUCTION AREA, EWEKORO, SOUTHWEST, NIGERIA.....208**  
*A.O. Majolagbe*  
*K.A. Yusuf*  
*A.E.Duru*
- APPROACH UNDER THE FORM OF SEMIQUANTITATIVE CYTOLOGICAL EVALUATION FOR CHRONIC PHARYNGITIS.....218**  
*Lydia Ferrara*  
*Daniele Naviglio*  
*Arturo Armone Caruso*

- IN VIVO ASSESSMENT OF GROWTH PROMOTING ACTIVITY OF A SYNTHETIC B-FGF IN WOUND HEALING OF RAT'S SKIN.....222**  
*Ayoub A Bazzaz*  
*Fatin O Bukhari*  
*Zumrud A Bazzaz*  
*Noorhan A Chelebi*
- GAMMA IRRADIATION PRESERVATION OF CHESTNUT FRUITS: EFFECTS ON COLOR AND TEXTURE.....239**  
*Amilcar L. Antonio*  
*Angela Fernandes*  
*Albino Bento*  
*Armando Ferreira*  
*M. Joao Trigo*  
*M. Luisa Botelho*  
*Begona Quintana*  
*Elsa Ramalhosa*
- LONG-TERM PROGNOSIS AND MODES OF DEATH IN HEART FAILURE PATIENTS WITH REDUCED VERSUS PRESERVED LEFT VENTRICULAR SYSTOLIC FUNCTION.....246**  
*Adelina Mavrea*  
*I. Korpos-Gyalai*  
*Ioana Citu*  
*Oana Ancusa*  
*Aurora Bordejevic*  
*Mirela C. Tomescu*
- USING OF ACCELEROMETER IN REHABILITATION OF BRAIN DAMAGE PATIENTS WITH UPPER ARM PARESIS.....254**  
*Petra Sladkova*  
*Pavlina Oborna*  
*Olga Svestkova*
- PSYCHOTHERAPY IN GEORGIA: PAST, PRESENT AND FUTURE.....257**  
*Revaz Korinteli*
- MOLECULAR GENETIC DETECTION OF BACTERIAL VAGINOSIS AT KAZAKH WOMEN IN REPRODUCTIVE AGE.....264**  
*Axoltan Oradova*  
*Bilimzhan Duysembayev*
- RISK ASSESSMENT OF BENZENE, TOLUENE, ETHYLBENZENE, AND XYLENES (BTEX) IN PAINT PLANTS OF TWO AUTOMOTIVE INDUSTRIES IN IRAN BY USING THE COSHH GUIDELINE.....270**  
*Aliasghar Farshad*  
*Hamid Khabazi Oliaei*  
*Roksana Mirkazemi*  
*Shahnaz Bakand*
- VEGETATIVE CORRELATES OF COGNITIVE PROCESSES IN STRESS SITUATION.....277**  
*Anastasya V. Bakhchina*  
*Sophya A. Polevaya*  
*Sergey B. Parin*



**COMBINED TELMISARTAN / HYDROCHLORTHIAZIDE THERAPY OF THE PATIENTS WITH ESSENTIAL HYPERTENSION AND ASSOCIATED ATHEROSCLEROSIS OF THE LOWER EXTREMITIES' MAIN ARTERIES.....281***Nadiya Yarem**Viktoriya Bilochytska***INFLUENCE OF BUILDING FORM OF HOSPITAL ON ITS ENERGY PERFORMANCE.....286***Vladyslav Shchuchenko**Bernt Lie**Trond Thorgeir Harsem***ANALYSIS OF EFFICIENCY OF TEAM BASED LEARNING (TBL) TECHNOLOGY.....296***Klara Baildinova**Aigul Zhunusova**Anar Kuanysheva**Saule Maukayeva**Saule Kozhanova**Marat Zhanaspayev**Gulnar Nuralinova**Karlygash Tusupova**Almira Achmetova**Ainash Orazalina***KNOWLEDGE ABOUT HEPATITIS B INFECTION AMONG MEDICAL STUDENTS IN ERBIL CITY, IRAQ.....299***Samir M Othman**Abubakir M Saleh**Nazar P Shabila***ADJUVANT CHEMOTHERAPY EFFECTIVENESS FOR I-II STAGE NON-SMALL CELL LUNG CANCER (NSCLC) PATIENTS DEPENDING ON THE TUMOR MOLECULAR PROPERTIES.....306***O. P. Kolesnik***CONTROL OF HINDMARSH-ROSE MODEL BY NONLINEAR-OPEN-PLUS-CLOSED-LOOP (NOPCL).....314***Tounsia Benzekri***TEACHING MATHEMATICS WITH NEW TECHNOLOGIES, SOME PERCEPTIONS OF EFFECTIVENESS OF ICT USE IN MOROCCO.....320***Karima Hamdane**Mohamed Khaldi**Ali Bouzinab***DESCRIPTION OF HARMONIC QUASICONFORMAL MAPPINGS.....324***Anila Duka***THE CULTURAL LANDSCAPE OF GEORGIA: FOR A PARTICULAR BORDERLINE OF THE GEORGIAN SITES SAFEGUARD.....328***Bianca Gioia Marino***RELATIONS BETWEEN THE TRADITIONAL WOODEN SACRAL ARCHITECTURE OF THE PODHALE REGION AND CONTEMPORARY ARCHITECTURE OF CHURCHES.....336***Kinga Palus*

<b>INCREASING THE CARRYING CAPACITY OF REINFORCED CONCRETE DRIVEN PILES BY CHANGING THEIR CROSS SECTIONAL GEOMETRY.....</b>	<b>342</b>
<i>Ala'a M. Darwish</i>	
<b>APPLIED THEATRE RESEARCH: DISCOURSES IN THE FIELD.....</b>	<b>347</b>
<i>Rikke Gurgens Gjaerum</i>	
<b>RICHARD WAGNER'S OPERAS IN 21<sup>ST</sup> CENTURY BALTICS: THE SAME WAGNER OR ANOTHER?.....</b>	<b>362</b>
<i>Lauma Mellena-Bartkevica</i>	
<b>METEOROLOGICAL AND HUMAN FACTORS INFLUENCE ON LEACHATE DYNAMICS.....</b>	<b>369</b>
<i>Vilda Grybauskiene</i> <i>Gitana Vyciene</i>	
<b>STUDY OF THE EFFECT OF CYANO SUBGROUP ON THE ELECTRONIC PROPERTIES OF AZULENE MOLECULE:B3LYP-DFT CALCULATION.....</b>	<b>377</b>
<i>Ghaidaa. A. Hafedh Jaber</i> <i>Basim Abdullattif Ghalib</i> <i>H. I. Abbood</i>	

# CRITICAL FACTORS IN MANAGING CUSTOMER-SUPPLIER RELATIONS

*Satya Jaya Aparna Pasi, M.Sc*

Department of Information Technology, Lappeenranta, Finland

---

## Abstract

This paper approaches the customer-supplier relations in tailored offshore software development projects. The objective of the study is to evaluate the critical factors that can accomplish the project lead's task to manage the project well. The root cause of software project failures is due to the problems in customer-supplier relations. An analysis of the literature suggests that the managing customer-supplier relations in tailored offshore software development have been relatively unexplored. Therefore, a detailed investigation of the critical factors in managing customer-supplier relations in offshore software development is presented. In this study we collected qualitative data through theme-based open-ended interviews, and analyzed it through a grounded theory approach. Our analysis shows symmetrical power relations, unrealistic promises in contract negotiations, expectation management, transparency and honesty, communication as factors in managing customer-supplier relations. We claim that these factors can be considered critical in managing offshore software development projects effectively.

---

**Keywords:** Software development, customer-supplier relation, critical factors

## 1. Introduction

Global software development has seen offshoring as a new established business practice (King 2005). One aspect of IT off shoring is the relocation of software services abroad to either near shore or offshore (Krishna et al. 2004), often referred to as offshore software development (OSD). This form of offshoring software development was considered relatively new in 2000's (Delmonte and McCarthy 2003), one of the main reasons for the advent of this particular business practice was the Y2K problem (Amoribieta et al. 2001). As a result, software is being developed remotely at the supplier premises without customer company interference and the development is based only on the guidelines that are provided by the customer team. Abundance of OSD project failures in terms of cost, time and quality can be found in media reports (BrrKOM 2005). Critical factors concept is gaining momentum in this era of OSD project management to facilitate successful implementation of OSD projects. King and Torkzadeh (2008) emphasized on researching the critical factors for offshore software development "as one of the most important issues for the future".

The customer-supplier interface is of big importance in software development. As any other interface, customer-supplier interface has its own set of challenges and ways to overcome them. As a result, the management of customer-supplier relations has attracted quite much of attention (Krishna et al. 2004, Oza and Palvia 2006; Alborz et al. 2003). Increase in such interest is reflected in magnitude change in work on software failures, and on how the customer-supplier relations can be made successful (Kern and Willcocks 2000; Lonsdale and Cox 2000). Despite of this, there remains a lack of research in the management of customer-supplier relations in offshore software development. Only few studies (e.g. Lacity, 2002; Kern and Willcocks, 2000; Kishore et al. 2004) concentrate on the critical factors to manage the relationship in offshore software development. Kern and Willcocks

(2000) suggest that customer-supplier relation is the area that has received least attention and that there have been numerous calls for further research.

Ensuring project success is not easy and that has been seen from many studies. For example, Ozonne (2000) reported that 20 – 25% of the relations between customer and supplier fail within 2 years, and 50% fail in 5 years. Lacity et al. (1995) claim that 70% of the customer companies whose projects are outsourced are unhappy with one or many aspects of the supplier companies. Adding to these studies few other studies prove that problems with the relationship between customer and supplier are the underlying causes for many software project failures (Foote 2004; Palvia, 1995; Prakhe, 1998; Miles and Snow, 1992).

According to Kern and Willcocks (2000) relationship can be managed if issues such as communication, information exchange and cultural convergence can be addressed. During his study on supply chain Brereton (2004) came up with mutual respect and willingness to share information transparently as other critical factors in managing relationships. Other researchers claim that level of customer satisfaction, achievement of expectation and project lastingness are the factors that define the success of customer supplier relationship (Stratkowski and Billon 1998). In their study, Kishore et al (2003) found that mutual understanding between the customer and supplier teams plays a vital role in customer-supplier relationship success. From the above studies, it is wise to conclude that prior research study results in managing customer supplier relation factors can be interpreted differently due to the fact that they vary and are undefined.

Other fields of the customer-supplier relationships researched with numerous studies when compared to that of the software industry. For example organizational (Kramer and Tyler 1996), behavioural, management (Blois 1999), and social science fields (Gambetta 2000) include a great deal of research in managing various forms of relations. Lack of information on managing customer supplier relations in software development implies the fact that the area of customer supplier relation in software development received least attention and thus it is important to address this area to fill in the gap through empirical research contributions. As a result, a deep empirical investigation into critical factors in managing customer-supplier relationships in offshore software development can be helpful to establish the best practices for tailored software development, and to reap more benefits for the customer and supplier companies. In this spirit, we chose to undertake the following research question “*What are the critical factors in managing customer-supplier relations in tailored offshore software development?*”

In this paper we present the results of an empirical study that has been performed in two Finnish companies comprising 8 different tailored offshore software development projects. The objective of our study is to contribute to the lack of literature in understanding and managing the customer-supplier relationships in software development, and thus to answer to the calls from the research community. At the same time this study is also beneficial to practitioners as the work will help them to know more about managing relations with their customers. This work is done exclusively on tailored software development projects. The rest of the paper is organized as follows. In Section 2 we first introduce the research methodology, and data collection and analysis techniques. In Section 3 we describe the results. Finally, in Section 4 we discuss and conclude the paper.

## **2. Research Methodology**

Qualitative approaches are used widely in social sciences. Also engineering fields, such as software engineering have begun to use qualitative approaches when making inquiries into the activities of human organizations. This study attempts to understand customer-supplier relations in tailored offshore software development, and it is therefore also an inquiry into the human organizations in software development. The overall approach in this study is grounded theory (Strauss and Corbin 1998), where the units of analyzes are cases (Eisenhardt

1989). Data was collected through multiple interviews using theme-based interviews. Data analysis was carried out according to the principles of grounded theory (Strauss and Corbin 1998; Glaser and Strauss 1967).

The grounded theory (GT) evolves during the research process and is a product of continuous interplay between the analysis and data collection (Strauss and Corbin 1990). The GT method is useful in developing context-based descriptions and explanations of the phenomenon (Myers and Avison 2002). In selective coding data is refined and core categories selected. These categories form the main elements of the grounded theory. Due to the reason that data analysis and collection occur in interplay, coding is complete when theoretical saturation is reached. Thus, no new data appears from the data, and the concepts remain the same. In our study open coding started with identifying themes in all the transcripts. For example we identified commitment, additional values, being open from one transcript. These themes were further grouped into expectation management and transparency which represent the area of our research questions. This regrouping of themes is done in axial coding phase.

The fact that the critical factors in managing customer-supplier relationships have not received much attention in the software engineering research makes the topic well suited for qualitative research approach. It is claimed that the qualitative research approach is best suited to the areas that lack previous theories, and it has been found suitable for in-depth study in a given organizational setting (Benbasat et al 1987; Eisenhardt 1989; Yin 2003). The grounded theory approach is a well-known and respected qualitative research methodology for the data collection and analysis that uses a systematically applied set of methods to generate an inductive theory about substantive data. Seaman (1999) reports that the theory-forming grounded approach suits well for the identification of new theories and concepts. Furthermore grounded theory has been found to fit the study of software and information systems (e.g. Hansen and Kautz, 2005; Kirsch and Haney, 2006; Seaman, 1999).

In our study we used theme-based interviews to collect qualitative data. In the beginning of data collection the research plan was sent to the department managers of two large Finnish software companies, who further forwarded the plan to the company's vice presidents. The first software company employed more than 800 people, and the second software company employed more than 400 people. Both of the software companies develop software for the forest industry. After being given the permission from both the companies to go ahead with the research we were given the list of the top managers, the middle managers, and the project managers for the interviews. The interviewees had in average an experience of 15 years in managing tailored software and information systems development projects, and they belonged to the leading positions in their departments. The data was collected using theme-based interviews during the beginning of March 2007 to April 2009. The interviews covered four themes: Background information; Customer and user participation and the factors influence on software and information system (IS) development projects and process; Phases of customer and user participation and level of following agreements; and Customer-supplier relationship management. The interviews were carried out with the upper managers, the middle managers (service manager, and department manager), and project managers. The interviews included frequent elaboration and clarification of the terms that were not understood by the interviewee. Finally the interviews were audio recorded, and transcribed to text yielding 300 pages of transcripts. Table 1 shows the demographics of the interviewees participated in this study.

Interviewee	Profile of the interviewee	Size of the project (person years)	Experience of interviewee in the software industry	Experience of interviewee in managing customer supplier relations in offshore software projects
I1	Upper manager	10	20 years	19 years
I2	Department manager	8	21 years	14 years
I3	Service manager	12	23 years	15 years
I4	Project manager	6	15 years	14 years
I5	Vice President		21 years	15 years
I6	Upper manager	10	19 years	17 years
I7	Department manager	5	14 years	12 years
I8	Project manager	9	15 years	13 years

Table 1: Demographics of the interviewees.

As seen from the Table 1, all the interviewees had more than 10 years of experience in managing the customer-supplier relationships in the tailored software development. The sizes of projects varied from one to another but overall all the projects were of medium size.

### 2.1. Data Analysis

The data collected through qualitative interviewing was analyzed through the broad principles of grounded theory approach (Glaser and Strauss, 1967). The aim of grounded theory is to develop a theory or categories from the data rather than to gather data in order to test a theory or hypothesis (Glaser and Strauss, 1967). Grounded theory can be presented either as a well-codified set of propositions or in a running theoretical discussion, using conceptual categories and their properties (Glaser and Strauss, 1967). A grounded theory is defined by Strauss and Corbin (1998:22) as

*'A set of well-developed categories (e.g. themes, concepts) that are systematically interrelated through statements of relationship to form a theoretical framework that explains some relevant social, psychological, educational, nursing or other phenomenon'.*

Coding is the central method of analysis in transforming data to theory or categories. Coding is defined as the analytic process through which data is fractured, conceptualized, and integrated to form a theory (Strauss and Corbin, 1998:3). Its aim is to develop and relate the concepts that are building blocks to theory. Categories emerge from similar concepts that have similar properties. Strauss and Corbin suggest that the categories should be grounded in the sense that they are formed from evidence in the research situation.

In this study data was collected from the interviews and the transcripts of each interview. Each transcript was coded using Strauss and Corbin's (1998) open coding method. Using the open coding technique, data is broken into discrete parts, closely examined and compared with each for similarities and differences. Events, happenings, actions and interactions that were found to be conceptually similar in nature or related in meaning were grouped under more abstract categories. Adhering to the grounded theory approach, we analyzed each interview transcripts in relation to our research objectives, and categorized data into high level categories defined in relation to our research objectives. Our aim for data analysis was to allow understanding to emerge from a close study of the data. Specifically, we analyzed each transcript and identified the major emergent themes, and concepts to group them in order to form categories of similar nature. Our analysis, identified four factors in managing customer-supplier relations for the research question that was mentioned earlier.

### 3. Results

To answer the research question *"What are the critical factors for managing customer-supplier relations in tailored software development?"* the interviewees of the study were asked the following two questions among other questions:

- What kind of difficulties you have had in managing the relations with the customer?
- What according to you are the important factors in managing customer supplier relations?

The answers to the questions above revealed factors for managing customer-supplier relations in tailored offshore software development, which are:

1. Symmetrical power relations,
2. Contract negotiations
  - a. Unrealistic promises in contract negotiations,
  - b. Expectation management,
3. Transparency and honesty,
4. Communication.

### 3.1. Symmetrical power relations

The loss of control in managing and ending the projects was the result of unbalanced power symmetry between the customer and the supplier. The power asymmetry means the imbalance that exists in between the customer and supplier. An upper manager and a project manager stated that there was a lack of control in managing and ending the projects even when the customer's terms were followed exactly while executing the projects. The lack of control resulted from an imbalance, or a power asymmetry between the customer and supplier. The power relation in which both the customer and supplier teams have an equal say, and liberty to conclude on similar terms without any kind of pressure will lead to a balanced relation between the two teams. Achieving a balanced power relation does not happen often because of the supplier's fear of losing the customer. The same was expressed in the words of an upper manager:

*"In general, too often the customer has too much power in these deliverables. We have to follow everything what has been agreed very exactly but when it is time to discuss about for example closing the project I have a feeling that we are really without power. For instance when the projects are big and your money is lying there on the customer table and you will get it when a certain acceptance is done and the customer can prolong that acceptance as long as they want to. And we have burnt that money before hand and in my mind it is not too often a fair play."*

The above mentioned customer attitude towards the supplier is causing a strain in the customer-supplier relation. Due to the fear of losing the customer, the suppliers are left with no or little power when it comes to the project ending as most of the deliverables are available to the customer, but the money matters are not yet settled between the customer and the supplier. The supplier company can face a financial crisis as the supplier team has already burnt the money even before getting it.

### 3.2. Contract negotiations

A contract is used between customer and supplier to regulate their expectations from project activities. A contract is considered as the most important tool to manage projects. Lacity and Hirschheim (1994) say that:

*'If a company decides to outsource, the contract is the only mechanism to ensure that expectations are realized'.*

However, it is unlikely that the contract can cover all possible future contingencies. For example, Brynjolfsson (1994) in his work on incomplete contracts theory notes that:

*'Real world contracts are almost always incomplete, in the sense that there are inevitably some circumstances or contingencies that are left out of the contract, because they were either unforeseen or simply too expensive to enumerate in sufficient detail'.*

Furthermore, Beulen and Ribbers (2002) in their work on software project contracts also claim that the opportunity to include all details in the contract is very limited. Beulen and

Ribbers relate this limitation to time pressure and the costs associated with the preparation of the outsourcing contract. For example, in some cases the company may consider it essential for certain software services to be quickly available. Therefore customer and supplier often agree on a procedure for dealing with changes that lead to situations that are not covered by the contract (Gietzmann, 1996). Contracts in software projects are almost always incomplete. It is difficult to include all relevant details in the contract. Therefore, the 'incomplete' nature of contracts means that a good working relationship between customer and supplier is necessary. The same nature of contracts is noted in our study as well. We reported the results regarding the contracts in two steps of unrealistic promises in contract negotiations and expectation management.

### 3.2.1. Unrealistic promises in contract negotiations

Another critical factor is about the unrealistic promises in contract negotiations. This ultimately results in deteriorating the customer-supplier relations. Either since the supplier team fails to meet the customer terms they have failed both schedule and budget by meeting the promises. Culprit for such failures is the unrealistic promises made by the supplier team. Hence, many of the interviewees reported that to have a proper understanding in terms of contractual issues leads to stronger customer-supplier relations in the offshore software development process. The same is reported by the upper manager and department manager:

*"We are too often forced to promise some things that we most probably know that we are not able to keep. First of all that causes harm for the project and then when you have sanctions settled in the contract that you are forced to pay something back if you are not in the schedule, you try to keep the schedule in every circumstances. Then you are starting to lose the quality, target and you are starting to fool yourself even trying to deliver every way and other what you have promised to. Then we are in bad quality problems, and too often there is no place for this kind of discussion that what if we transfer the schedule and they are no sanctions. But that's when we realize that yes we have failed with the schedule we have failed with quality and so on, and then we are coming to the problems. If we can avoid promising unrealistic outcomes then we can have a smooth relation with the customer" – Upper manager*

The upper manager felt that due to the competition from other companies, they are forced to accept everything that the customer wishes and wants. The same is also applied to the contracts, where they agree to pay a "certain sum" in case of the failed schedules. This keeps pressure on the team right from the early phases of the project, and leads to many levels of compromises in both the quality and schedules. A good quality product with all the promised specifications may require more time and budget than what is in the contract. This situation escalates when the customers are not ready to listen to the supplier, and no relief, such as extra budget or time, are given to the supplier team. Having said this, interviewees felt that it is important to add supplier company's own terms and conditions to the contract while it is being implemented. Omitting certain terms and conditions from contracts - such as extra payment fees to the customer if the supplier team fails in schedule, and giving a more flexible budget to the supplier team by the customer- can add to the project quality, which results in an end product that meets the customer expectations hence leading to a long term relation between customer-supplier companies.

*"So with the biggest customers we have this kind of company level agreements and special terms while acting with the company. But yes they are cases when the customer is saying that this template is to be used and they are not too many benefits for us in using such templates. But if you want to deal with that customer then you have to accept. In such cases unfortunately we are doing quite much that kind of work that we don't get any budget. It also has an affect for the schedule that there is this kind of hidden work that we are doing which is*



*not visible for anyone, and yeah it causes harm for all the aspects in the project and customer relations.” - Department manager*

The department manager stated that sometimes even though they do not see any benefits from the contracts with certain customers, they say *yes* to the contract to keep up the business with them, and by doing so the supplier team is forced to do hidden work that is not seen by anyone, and is not budgeted, and this affects to the project overall. These hidden works can delay project schedules and strain the customer supplier relations.

### **3.2.2. Expectation management**

The data showed that another critical factor reported by most of the interviewees is the expectation mismatch in the deliveries. Many interviewees felt managing the expectations from the customer side as challenging and difficult. The suppliers reported that both their team and the customer team should know what they are going to achieve from the project. In many projects, customers assume that they get a lot more than what the supplier can offer. Seldom have the both teams discussed these expectations, which may result in end product expectation mismatch. An understanding between the teams can be achieved through regular meetings and stating all the expectations clearly during requirement specification phase. Suppliers further state that all the expectations should be discussed, reported and agreed.

*“Expectation mismatch is always there in the IT projects, this kind of change management in the customer organization must be done in much better way that it is done. Because if you think of a new delivery, lets say that it is totally new system or renewal for the customer. Previous system customer thinks very often that he will get all the features that were there in the previous system which was developed 25 years before and then they will get those add-ons and everything works smoothly. Really it happens in all the IT projects. Their expectations are much higher than in the beginning. It varies from company to company and we have to be very careful in what we are saying. Customer can say anything but we need to be careful. If these expectations are clear then we do not have any tensions between our teams.” – Vice president*

### **3.3. Transparency and honesty**

Suppliers identified transparency as one of the critical factors. By transparency we mean the actions and outcomes of supplier's work in terms of the communication that take place, processes followed or any other actions performed in respect to the outsourced work. Suppliers mainly highlighted the importance of transparency in their processes, demonstrating the progress of the project and communication. Particularly, transparency will increase customer's confidence on controlling the outsourced work to the supplier. A department manager said:

*“I think being open is one of the most important things. You need to be honest not to hide any mistakes that you have made. We need to respect our customers, we need to respect their wishes, and we need to be honest on that side that if you cannot deliver or you cannot do the job you need to tell it. Don't promise more that what you can deliver or handle.” – Upper manager*

In relation with the transparency, many interviewees emphasized the importance of being honest as another critical factor. By honesty we mean working honestly in tailored software development relationships. Suppliers reported that honesty required at both ends in transactions. The same is reported by the two managers.

*“Honesty is really important, and we try to be very open and that we expect from the customer side, too. Every project is with cooperation and we get success only with good cooperation. Openness and trust are the key issues there.”*

*“We have to be professionals in these IT projects by being honest and transparent.”*

### 3.4. Communication

Maintaining constant communication with the customers was another frequently identified critical factor. The software vendors identified various means of communication, including an email, the phone calls, conference calls, net meetings, and video conferencing as an essential part of maintaining a healthy relationship. Most of the interviewees reported that communication is important in the initial stages to establish the relationship. Additionally they also mentioned that giving the information that customer wants and giving that often will help in building the relationship. Maintaining such communication helps to carry the relationship between customer and supplier teams for a long time. A project manager reported that there should be constant communication in the beginning of the project even though they do not have much to discuss. These means of communication can help both teams to know each other well and henceforth will help in leading a long term relationship.

*”Every project is with communication and cooperation and we get success only with good cooperation. Daily communication is another factor and having good relation and openness between them is important.” – Service manager*

*“Keeping up the conversation with the customer, giving the information that customer wants and giving it frequently so that they don’t forget that you are there. Then we have frequent meetings, to keep the communication on an excellent level.” – Upper manager*

*”The most important aspect is to have regular communication between these two teams of customer and supplier. Even if you have no clear agenda in the beginning, it is even more important to just have time to communicate in the beginning of the project and to get people to know each other. That’s really quite important and also after that to have quite regular communication between these two teams is essential for the relation to go on for a long run.” – Project manager*

## 4. Discussion and Conclusions

Our study examined the critical factors in managing the customer-supplier relations in tailored offshore software development, and the study shows a correlation between the prior work of Oza and Palvia (2006), Kern and Willocks (2000), Brereton et al. (2004), and Remus and Wiener (2009). Lacity (2002) on the basis of long term research experience in outsourcing suggests that the ability to commit to what was agreed, to fairly adapt to change, and to identify value-added services are critical. Nam et al. (1996) emphasise the technical competence of the vendor as critical in the relationship. Results of our work are correlating with critical factors identified in these studies.

The most crucial factors managing the customer-supplier relationships were symmetrical power relations, unrealistic promises in contract negotiations, expectation management, transparency and honesty, and communication. The communication mainly involved undertaking regular meetings and exchanging the information regularly with each other over the phone and emails. In our study, however, we also found out symmetrical power relations and contract negotiations as new factors adding to the list of factors in the areas current state of research. Our results thus point out the fact that these all are important factors in managing the customer-supplier relationship in tailored software development. Summary of the same results is presented in Table 2.

Critical factors	Discovered in our study	Literature reference
Symmetrical power relations	Lack of control in project implementation	Discovered in our study
Unrealistic promises in contract management	Contracts are not done with mutual agreement and very often according to customer company views	Discovered in our study
Expectation management	Have a clear idea on what to expect, and what to not expect from the project being implemented	Oza and Palvia 2006; Kern and Willocks 2000; confirmed by our study
Transparency and honesty	Be open and clear with the customer team, even if the supplier team is at fault	Oza and Palvia 2006; Reimus and Weiner 2009; confirmed from our study
Communication	Maintain clear and constant communication for cooperation with the supplier team	Oza and Palvia 2006; Reimus and Weiner 2009; confirmed from our study

Table 2: Summary of critical factors.

This study has several practical implications. First, our empirical investigation will help the companies to understand the potential factors mentioned in our results that could be faced in managing the software development projects. Second, the emergent critical factors reported in this study can help the companies to understand the current practices needed for managing customer-supplier relationships. Third, it may be worth to explore the similar critical factors experienced in the other countries. Fourth, the research approach established in this study may also be replicated by collecting similar data from destinations other than Finland.

Though we have only used broad principles of grounded theory in this study, emergent themes of the empirical study will help us to build the basis for substantive theory in managing customer-supplier relationships. Our study however has some limitations. Data collection method, the standardized open ended interview, is limited in the sense that it reduces the extent to which individual differences and circumstances can be taken into account (Patton, 1980). Furthermore, in this study, the participating companies identified the interviewees based on our criteria. Therefore, we could not measure how the participating companies identified the interviewee, and we addressed this limitation in two ways. First, we did not release the interview questions until we conducted the interview. Thus, the participating companies did not have knowledge of the questions of the interview while selecting the interviewee. Second, during the interview we asked from each interviewee her/his personal background. This gave us information on their educational background, and commercial experience in the context of managing software projects, and thus customer relations and working in the software industry.

Our investigation provides a preliminary outline of the factors in managing the customer supplier-relationships. However, the information provided by the suppliers can be considered as highly reliable due to their long experience in the software industry, outsourcing business, and their senior position in the companies. Furthermore, the participating companies have been successful outsourcing software suppliers for many years with the experience of a number of successful outsourcing projects, and high maturity processes. Studying only the software projects which were in progress while collecting the data can be considered as a drawback, since the outcome of those projects are unknown. In the future studying the failed software projects could give more insight into the better ways of managing the customer-supplier relations in offshore software development. Further research in all critical factors is needed to shed more light in this area, and this study could be extended to countries other than Finland, and by doing this our study could be cross verified as well.

**References:**

- Adelakun, O., and Jennex, M.E. 2003. Success Factors for Offshore Information System Development. *Journal of Information Technology Cases and Applications*, 5 (3).12-29.
- Amoribieta, I., Bhaumik, K., Kanakamedala, K., and Parktie, A.D. 2001. Programmers Abroad: A Primer on Offshore Software Development. *The McKinsey Quarterly*.
- Alborz, S., Seddon, B. and Scheepers, R. A. 2003. Model for Studying IT Outsourcing Relationships. 7th Pacific Asia Conference on Information Systems, Adelaide, South Australia. 1297-1313.
- Benbasat, I., Goldstein, D. K. and Mead, M. 1987. The case study research strategy in studies of information systems, *MIS Quarterly*. 11 (3). 369-386.
- Berger, A., Hodel, M., and Risi, P. 2004. Outsourcing realisieren. Wiesbaden: Vieweg.
- BITKOM. 2005. Leitfaden Offshoring. Retrieved 23.11. 2011, from <http://www.bitkom.org>.
- Brereton, P. 2004. The software customer/supplier relationship. *Communications of the ACM*. 47(2). 77 – 81.
- Brown, D., and Wilson, S. 2005. *The Black Book of Outsourcing - How to Manage the Changes, Challenges and Opportunities*. New Jersey: John Wiley & Sons.
- Blois. K. 1999. Trust in business to business relationships: An evaluation of its status. *Journal of Management Studies*. 36(2). 197-215.
- Delmonte, A.J., and McCarthy, R.V. 2003. Offshore Software Development: Is the Benefit Worth the Risk? *The Ninth Americas Conference on Information Systems*, Tampa, USA.
- Eisenhardt, K.M. 1989. Building theories from case study research. *Academy of Management Review*, 14(4). 532-550.
- Foote, D. 2004. Recipe for offshore outsourcing failure: Ignore organization, people issues. *ABA Banking Journal*. 96(9). 56 – 59.
- Gambetta, D. 2000. *Trust: Making and Breaking Cooperative Relations*. Electronic Edition, Department of Sociology, University of Oxford.
- Glaser, B. and Strauss, A. 1967. *The Discovery of Grounded Theory*. London: Weidenfield & Nicolson.
- Hansen, B. H. and Kautz, K. 2005 *Grounded Theory Applied - Studying Information Systems development Methodologies in Practice*, Proceedings of the 38th Annual Hawaii International Conference on System Sciences HICSS '05.
- Kern, T. and Willcocks, L. 2000. Exploring information technology outsourcing relationships: theory and practice. *Journal of Strategic Information Systems*. 9. 321-350.
- King, W.R. 2005. Outsourcing and Offshoring: The new IS Paradigm? *Journal of Global Information Technology Management* (8:2). 1-4.
- King, W.R., and Torkzadeh, G. 2008. Information Systems Offshoring: Research Status and Issues. *MIS Quarterly* (32:2). 205-225.
- Kirsch, L. J. and Haney, M. H. 2006. Requirements determination for common systems: turning a global vision into a local reality. *The Journal of Strategic Information Systems*, 15 (2). 79-104.
- Kishore, R., Rao, H. R., Nam , K., Rajagopalan, S. and Chaudhury, A. 2003. A relationship perspective on IT outsourcing. *Communications of the ACM*. 46(12). 87 – 92.
- Kitchenham, B., Pickard, L. and Pfleeger, S.L. (1995). Case studies for method and tool evaluation. *IEEE Software*. 52 - 62.
- Kramer, R., and Tyler, T. 1996. *Trust in organizations: Frontiers of theory and research*. Thousand Oaks, CA, US: Sage Publication Inc.
- Krishna, S., Sahay, S. and Walsham, G. 2004. Managing cross-cultural issues in global software outsourcing. *Communications of the ACM*. 47(4). 62 – 66.
- Lacity, M. 2002. Lessons in Global Information Technology Sourcing. *IEEE Computer*. 35(8). 26 - 33.

- Lacity, M.C., Willcocks, L.P. and Feeny, D.F. 1995. IT Outsourcing: Maximize Flexibility and Control. *Harvard Business Review*. 84-93.
- Lonsdale, C. and Cox, A. 2000. The historical development of outsourcing: the latest fad? *Industrial Management & Data Systems*. 100(9). 444-450.
- Miles, R., Snow, C. 1992. Causes of Failure in Network Organizations. *California Management Review*. 53 – 72
- Myers, M.D., and Avison, D. Eds.2002. *Qualitative research in information systems: A Reader*. London: Sage Publications Ltd.
- Nam, K., Chaudhury, A., Raghav Rao, and H., Rajagopalan, S. July 1996. A Two-Level Investigation of Information Systems Outsourcing. *Communications of ACM*. 39(7). 36 - 44.
- Oza, N. and Palvia, S. 2006. Critical factors in managing offshore software outsourcing relationships. *Global Information Technology Management*. 4<sup>th</sup> edition. Ivy League Publishing: USA.
- Ozanne, M. R. 2000. *Barometer of Global Outsourcing-The Millennium Outlook*. Dun & Bradstreet.
- Palvia, P. 1995. Case Study: A dialectic view of information systems outsourcing: Pros and Cons. *Information and Management*. 29. 265 – 275.
- Parkhe, A. 1998. Building trust in International Alliances. *Journal of World Business*. 33(4). 417 - 437.
- Patton, M. Q. 1980. *Qualitative evaluation methods*. Sage Publications.
- Remus, U. and Wiener, M. 2009 Critical Success Factors for Managing Offshore Software Development Projects. *Journal of Global Information Technology Management*, 12(1). 6-29.
- Seaman, C. B. 1999 Qualitative methods in empirical studies of software engineering, *IEEE Transactions on Software Engineering*, 25 (4). 557-572.
- Strauss, A. and Corbin, J. 1998. *Basics of Qualitative Research: Techniques and Procedures for Developing Grounded Theory*. Sage publications.
- Strauss, A. L. and Corbin, J. 1990 *Basics of Qualitative Research: Grounded Theory Procedures and Applications*. Sage Publications: Newbury Park, CA.
- Stralkowski, C. and Billon, S.A. 1988. Partnering: a strategic approach to productivity improvement. *National Productivity Review*. 7(2). 145-151.
- Yin, R. K. 2003. *Case study research: design and methods*, Sage Publications.

# MULTI-PORT ELECTRIC STIMULATION SYSTEM USING HIGH SPEED PROCESSORS

*Lopez de la Fuente*

*Martha Salome, PhD*

University of Monterrey, Mexico

---

## Abstract

Electric signals are used in research areas as stimulus in tests: in body fluid samples to find a specific type of cells, particles, viruses or bacteria, in water samples to find pollutant agents, in blood samples to count T-Lymphocytes as cancer evidence, in food samples to determine safety, in prosthetics development for functional tests, in biotechnology to determine cell development stage, and several other fields. Currently, generic equipment such as standard signal generators is used to deliver the needed electric signals to the experimental setting. Generic equipment requires knowledge in the electric field, that researchers in biological and medicine fields do not have. Besides, it is expensive and delivers a limited type of signal waveforms. This paper presents the idea, design, implementation, and results of a flexible, programmable, multi-purpose device for delivering multi-waveform signals for a variety of applications. The idea is to develop a device which delivers different waveforms, single or superimposed, to several ports, where signal parameters such as amplitude, frequency, phase, waveform and repetition pattern are defined by the user. The design is based on a high speed processor, a Harvard architecture memory, a communication/configuration port, and 8-bit IO ports. A prototype is developed using an ARM processor based board, a C++ application program, and a User Interface. Specifications achieved: self contained, configurable, programmable, Vout up to 200Vpp, frequency 1Hz-40kHz, 4 waveforms (sinusoid, triangle, square, and saw-tooth), single, dual, or superimposed signals, waveform combination, single triggered outputs, continuous execution, and programmable repetition patterns.

---

**Keywords:** Embedded systems, electric stimulation, particle manipulation

## Introduction:

There is a need for reliable, portable, low cost devices, which can be used in research and experiments that require electric stimulation. Clinic analysis, water quality, food quality, genetic analysis, prosthetics, cancer research, cell differentiation and characterization, are research fields that can be beneficiated by this device. Research experimentation and testing require multiple repetitive stimulation varying parameters that may produce different effects or to prove that an experiment is developing as expected. A variety of signals, patterns and stimulation is needed, and existing equipment is of little use for researchers. Besides, biologists, medical staff, and doctors do not have the knowledge in electric, electronics and programming to operate or configure standard equipment, so their research advance and results slow down and depend on other people. The system detailed in this paper presents a portable, inexpensive device, that can be configured and operated easily, and provides any signal and pattern a researcher may need, by varying a few parameters and by connecting easily to any experimental setting. This way, a multi-purpose stimulation device is achieved, resulting in a configurable, programmable, and autonomous system. It can easily be modified to extend its use to other areas, by adding modular programming or including signal patterns

that do not follow a known behavior. The device software and user interface can be installed in any portable computer, and data can be stored from past experiments for future reference. A simple User Interface allows the researcher to set up, change and repeat experiments by changing the signal parameters. An infinite combination of signal patterns and stimulation can be achieved by varying amplitude, frequency, waveform, and repetition periods. This paper shows the system design and functionality, and a brief background of the application areas.

### Background on electric stimulation

The use of electric stimulation in several research areas is well documented; for example, small voltage signals are used in clinic analysis when looking for virus and bacteria in blood and urine; dielectrophoresis (DEP) is the phenomenon used for manipulating and separating dielectric particles and cells by suspending them in a fluid and using electric stimulation to generate electric fields in between, producing a controlled motion on the particles; in water and food freshness, samples are electrically stimulated to separate, count and extract pollutant agents; in flowing liquids, separation and filtration of undesired particles is produced by energized electrodes with electric stimulation of a specific frequency and phase. This research and analysis require reliable stimulation and experiment repeatability, in a way that precise and consistent results can be obtained, and used for further analysis.

In recent years, new applications for electric stimulation have been emerging: sinusoid waveforms are used to manipulate the DNA chain, electric signals are used to manipulate Cytotoxin in T-Lymphocytes, which are indicators of toxicity or cancer, and so on.

The proposed idea and implemented prototype, shown in this paper, may lead to a multi-application portable device which can deliver electric stimulation to a wide variety of research areas. Also, the prototype can obtain and store data related to the experimentation results, so it can be further analyzed to understand research results. Currently, most of the research and experimentation work is done with standard signal generators, setting operation parameters manually, by researchers with no background on electronics, all of which lead to slow, imprecise, not repeatable experimentation.

Examples of applications and the electric stimulation they use, are shown in Table 1.

Table 1. Ongoing research based on electric stimulation	
Application	Electric stimulation
Route different particles in one fluid sample	Sinusoidal, 200Hz, 100Vpp
Detect and manipulate pollutant particles in water	5 to 500KHz, 150Vpp
Manipulate poly-styrene testing beads	Sinusoidal, 1Khz-5MHz
Trap and sort proteins in DNA	2 opposite sinusoids, 8Vpp, 1MHz
Detect virus and cells in blood samples.	2 phased sinusoids, 10V, in the range of KHz
Separate and count T cells in blood for HIV diagnose	Sinusoide, 6Vpp @ 50KHz
Separate red blood cells from other cells	Superimposed frequencies, phased sinusoids, 6Vpp, 200KHz
Manipulate and separate MD23 cancer cells	Sinusoide, 10Vpp, 50KHz
Manipulation of pathogens in body fluids	Sine, 10V, 1 MHz AC/DC

**System design.** The idea of an autonomous system begins with a high speed processor that can run an application program fast enough to deliver continuous voltage samples that can be converted into a cyclic waveform. Tables in memory can contain the data samples that represent different waveforms. Efficiency in memory storage size can be achieved by storing only a fraction of a waveform, when possible, for example on sinusoids:  $\frac{1}{4}$  of the cycle contains the same information as the other  $\frac{3}{4}$ s. Output ports can be digital 8-bit IO, since 256 values scale is enough for up to 1mV steps. Digital to analog converters and analog filters are connected to the digital IO ports to convert the data samples into a continuous voltage signal. A cyclic execution of the application program produces a continuous sinusoidal signal. Different waveforms, not considered in the mentioned basic 4, can easily be added to the system by sampling a full period of the desired signal and representing it as a table of data

samples. The number of data samples used to construct any waveform does not need to be the complete set of samples stored in the memory tables: as fewer samples are used, higher frequencies can be achieved since it takes less execution time for the processor to go from the first through the last point. A user interface allows selecting configuration and operation parameters. Open source code can be modified to add functionality or new waveforms.

This stimulation system can be used as an autonomous component or as part of a LoC (Lab-on-Chip) design, when miniaturized. The complete system is shown in Figure 1: the User Interface allows parameter and operation configuration, the Electrical Stimulation System Prototype delivers digital data according to the selected configuration, the Signal Processing module converts the digital data into analog signals, the Experiment Setup contains the device to be stimulated, and the Monitoring and Feedback line carries information sensed in the experiment to determine adjustments in the stimulation. The Experiment Setup module depends on the research area, for example on particle manipulation it can be a video microscope to see the manipulation effects; in prosthetics testing it can be a prototype being stimulated to observe the mechanical response, and so on. Every block modules require minimum or no changes when migrating from one research area to another.

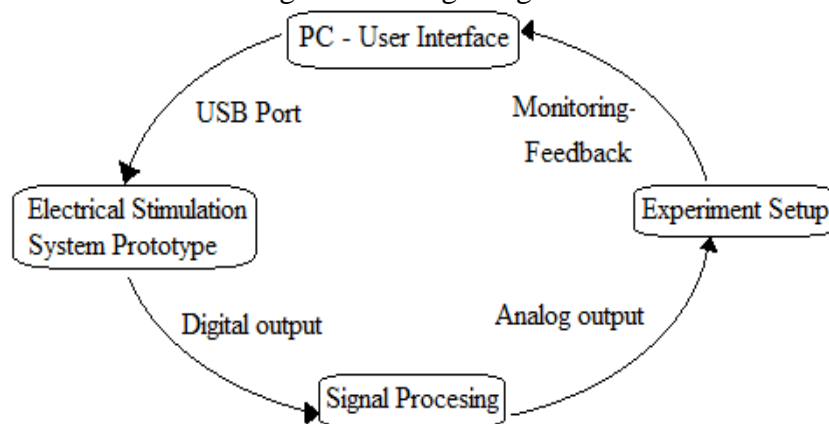

Figure 1. Block diagram of a complete Stimulation System

The application software, that delivers the output digital data to form the stimulation patterns, was developed in C++ and runs on an ARM processor based development board. The application program is stored in an EEPROM and a RAM array stores the waveform samples and the temporary data generated during execution of experiment. The system includes a USB or RS232 port for programming and configuration, and parallel ports are used as four 8-bit GPIO (General Purpose Input Output).

The application software architecture can be summarized as follows:

Set-up: Accept user parameters to define execution and signal generation scheme.

Select signal outputs: Determine, based on user parameters, the data tables, timing, and data separation to be used in signal generation.

Configure operation: Determine algorithm to construct the data table to be used for signal output.

Memory data tables: Use base data tables to extract samples for 1 or 2 separate signals; use base data tables to construct temporary data table for operation mode 3 (superposition of 2 signals).

Waveform superposition. A special case of signal generation occurs when a user needs to mix 2 different waveforms and frequencies to produce a unique output signal. This is useful when 2 different motion or manipulation effects are desired at the same time, over the same sample or device. A timed mix of data samples has to be achieved and stored in a temporary memory table, before signal generation occurs, so execution time is only used for output delivering but not for signal building. Figure 4 explains the way a 2-waveform, 2-frequency signal is achieved from base data tables, and stored into the temporary table.



The hardware architecture is represented in Figure 2.

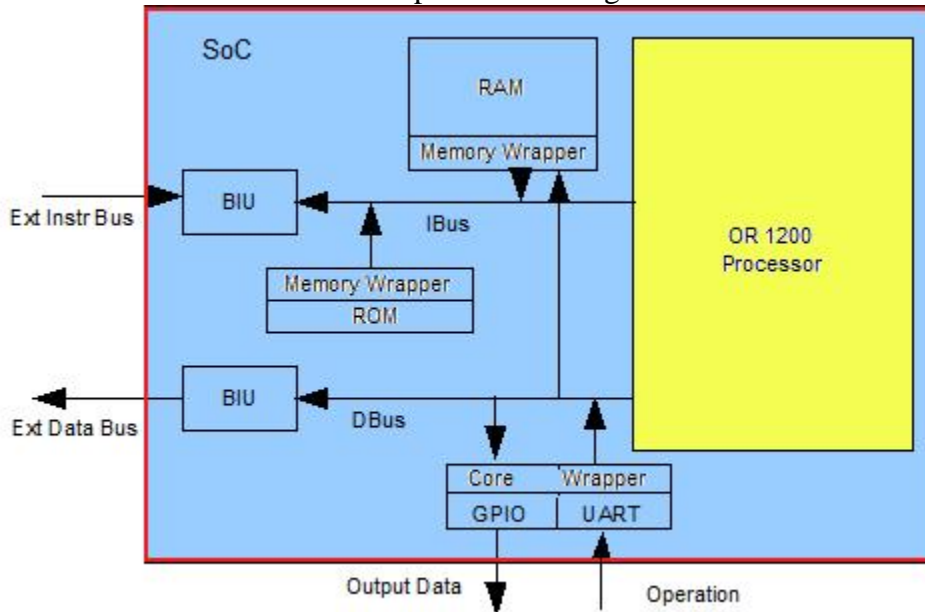

Figure 2. Hardware architecture of the Electric stimulation system.

Processor: executes the application program using maximum crystal frequency to achieve maximum frequency in the output signals.

Application program memory. Several programs were tested, mainly evaluating 2 schemes: Memory intensive versus Computation intensive. The core of the memory intensive scheme is the use of data tables containing the sampled waveforms. The core of the computation intensive scheme uses Taylor series to calculate up to 4 decimals the value of the signal samples; more decimals were not needed due to the effect of the external filter. Figure 3 shows both. The selection, for maximum output frequency, was Memory intensive scheme.

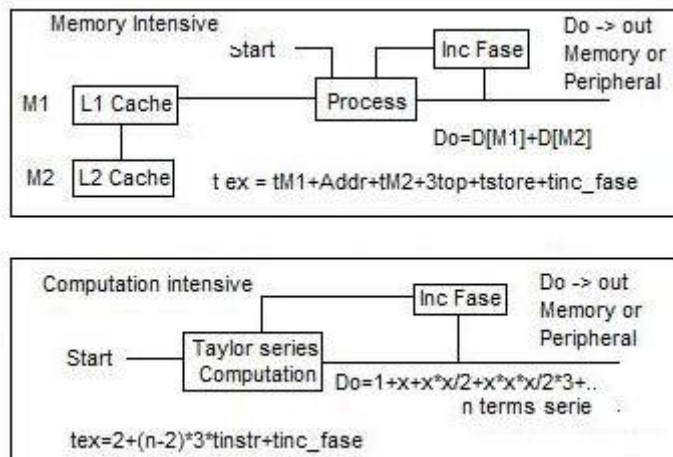

Figure 3. Memory intensive versus Computation intensive.

Data memory. Contains 2 types of data tables: the permanent tables containing waveform samples used to construct and deliver the signal for all the operation modes, and the temporary tables calculated prior to execution of operation mode 3, because the superposition of 2 signals has to be calculated before in order to not to take time for it when delivering the signal. This is the key to obtain maximum frequency output even when superimposing 2 signals with very different frequencies. This procedure is shown in Figure 4.

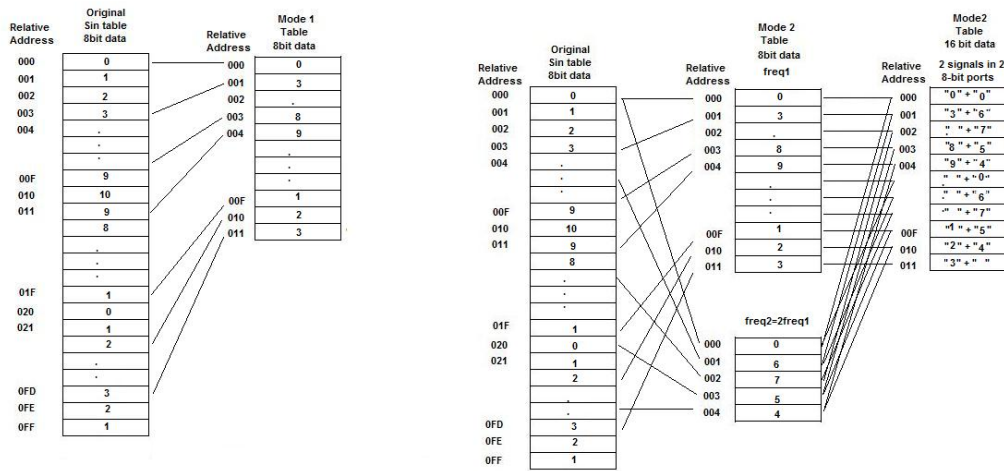

Figure 4. Data table construction for 1 and 2 signals.

**IO Port.** Two 8-bit IO ports are used to deliver digital data to external Digital to Analog Converter (DAC) and then to analog filter. 8 bit ports allow internal data tables of 256 data values for signal samples.

**Communication port.** A USB port is used for programming, operation, and configuration of the prototype. Programming allows adding future additions to the current application program; operation allows using a regular personal computer to install the development software and the user interface; and configuration allows executing the program under selected parameters via the same computer or as a standalone module.

**Open source code.** When needed, open source libraries were used in order to keep a low cost on the prototype.

**Signal conditioning.** As the processor based system delivers digital signals, a digital to analog conversion, filtering, and in some cases amplification, is needed as an external circuit. All tests were successfully completed for the signal parameters intended in this work.

The interface shown in Figure 5 allows the user to easily select and define the parameters for the operation.

```

Signal Generation System
Configuration and Operation
*****
*****
Run program as
    1)Time based run
    2) Variable pattern run, timed
    3)Frequency sweep
*****
*****
Select Operation mode
    1)Single Frequency
    2)Dual Separated Frequencies
    3)Dual Superimposed Frequencies
*****
*****
Select Signal Output Type
    1)Sinusoidal
    2)Triangle
    3)Square
    4)Sawtooth
Frequency for Signal 1 (Hertz):
Frequency range if sweeping (Hertz):
Number of samples per Cycle:
*****
*****
Select Signal Output Type 2 (for Op. Mode 2 or 3):
    1)Sine Waveform
    2)Triangle Waveform
    3)Square Waveform
    4)Sawtooth Waveform
Frequency for Signal 2 (Hertz):
Number of samples per Cycle:
ENTER for System to run

```

Figure 5. User Interface: to configure and operate the signal generator.

First, to select if the signal will be delivered by a finite amount of time, if the waveform should change automatically during execution, or to make a sweep over a frequency range. Then, to set the operation mode: select a single signal, or 2 signals over 2 different output channels, or 2 different signals superimposed to deliver on 1 single output. Then to set the type of waveform, the frequency, and the data samples per signal cycle. The amount of samples per cycle impacts the maximum achievable frequency, so small numbers are recommended for high frequencies. Last, for operation modes 2 and 3, parameters for the 2<sup>nd</sup> signal are set. No signal delivery occurs until all the parameters are set and the final Enter is typed; this is due to the importance of the timing in certain experiments.

**Functional specifications.** The prototype has been tested in different development boards from several commercial brands, so its portability is fully demonstrated: it runs on a LM3S6965 Luminary micro board, on a Tower system from Freescale, a Kinetis Quickstik from Freescale, and on an Arduino II. The best performance has been achieved by the ARM processor based boards, as they are intended for real time applications. If system is transferred to a board other than the mentioned, full frequency range can be achieved by a processor running on a 50 MHz or higher clock, an a program memory of at least 256 kB, data SRAM of 64kB or more, and two 8-bit General purpose IO. A USB port is highly recommended since it provides input for in-field programming and configuration. If a battery or energy source is provided, the system can operate as an autonomous system. If long term storage is needed for data resulting from repeated experimentation, a personal computer attached to the system is recommended. After rounds of improvement in software and hardware, the functional specifications of this Electrical Stimulation prototype are shown on Table 2.

Table 2. Device specifications	
Waveforms	Sinusoidal, triangle, saw-tooth, and square
Frequency Range	1 Hz - 40 kHz
Data samples per signal cycle	From 8 to 256
Output amplitude	200Vpp
Output configurations	Single output, dual output, 2 dephased outupt. 2 separated waveforms, 2 superimposed waveforms
Output Types	Single, Dual, and Superimposed Output (whether using frequency sweep, or simple output mode)
Application software	Modular, generates waveforms, stores, repeat patterns
Hardware architecture	Stand-alone module, foundation for a lab-on-a-chip

The prototype was tested to show that it delivers the kind of signals mentioned above; results for the intended frequency range and waveforms were successfully achieved. Figure 6 shows the experimental setting and the stimulation system.



Figure 6. User interface, Prototype board, Signal viewer. Development board: The LM3S6965 prototyping a) ARM® Cortex-M3 Processor, b) GPIO, c) USB port, d) Reset, e) Memory card slot for data and/or program.

Examples of the waveforms obtained: Simple sinusoid, simple triangle, simple sawtooth, triangle superimposed over a sinusoid, sawtooth superimposed over a triangle, triangle superimposed over a sawtooth, and so on. Also, tests were conducted in order to ensure that different frequencies can be achieved during superposition, as it is shown in Figure 4. Different number of data samples were used in tests, to ensure waveform remain consistent regardless the amount of samples; this is achieved due to the external analog filter. These signals prove to be useful in the research areas mentioned in table I; the parameters achieved are 200Vpp maximum, of up to 40KHz. Ongoing work is in process to extend the frequency range in order to reach additional research areas. Figure 7 shows examples of the various patterns and superposition that can be delivered by the system.



Figure 7. Examples of the delivered signals, different waveforms, different frequencies.

**Future work.** As use of this system finds its way through on-going research areas, additional functionality will certainly arise. Audio systems and prosthetic devices use signal patterns very different from standard sinusoids and saw-tooth, and they can also be characterized and represented with data tables. Some areas require closing the experimentation loop by sensing a physical variable to further correct the stimulation signal; current system can receive input signals from any digital sensor, so its information can be integrated into the user selection when deciding the signal and operation parameters. Future work also includes breaking the dependence of the maximum frequency output from the processor clock speed, by adjusting the time between samples when mixing data samples from 2 or more different waveforms. An interesting addition is in progress: once a user finds the tests which are usually performed, the stimulation parameters can be saved in the system

for future use, so several tests can be saved as TestFreq1, TestFreq2, and so on; this way, the configuration and operation parameters can be saved and used later, to ensure that the exact same stimulation is used and can be compared to previous research results.

### **Conclusion:**

Experiment stimulation using electric signals is needed in several research areas. Generic equipment such as signal generator is available but do not fulfill the need for user configuration, programming, variety of waveform patterns, and operation. The prototype presented in this work delivers electric signals over a wide range of parameters, as an autonomous portable device. It can deliver any combination of different waveforms over up to 4 output channels. Open source software is provided for this application and it can run on different commercial hardware platforms. Future work on this prototype is in progress, to add new waveforms, deliver higher voltages, wider frequency range, and to integrate sensors for giving feedback to the system so it can auto-adjust signal outputs.

### **References:**

- M. Salome-Lopez, G. Andreas, A. Alfonso, S. O. Martinez-Chapa. "A programmable and configurable Multi-port System-on-Chip for stimulating Electrokinetically-driven Microfluidic Devices" International Conference of the IEEE Engineering in Medicine and Biology Society IEEE (EMBC 2011), Boston MA, USA, 2011
- Martha Salome Lopez, Blanca Lapizco-Encinas, Sergio Martinez Chapa, An electric stimulation system for electrokinetic particle manipulation in microfluidic devices, Review of Scientific Instruments Journal, USA, 2013.
- Martha S. Lopez, Jose A. Benavides, An electric stimulation system for research and testing, Electronics, Robotics and Automotive Mechanics Conference (CERMA, IEEE) México, 2012.
- M. Salome-Lopez Definition, Design, and Implementation of a Processor-Based Stimulation System for Electrokinetically-Driven Fluidic Devices, Instituto Tecnológico y de Estudios Superiores de Monterrey, México. 2011
- S. O. Chacón, B. H. Lapizco-Encinas, M. Rito-palomares, E. Collado-Arredondo, S.O. Martinez-Chapa. "Dielectroforesis con estructuras Aisladoras" Chemical Engineering Mexican Journal, Universidad Autónoma Metropolitana, Iztapalapa México, 2007. Vol. 6 (3)
- I. C. Young, A. F. Alexander. "Application of pulsed electrical field for advanced cooling and water recovery in coal-fired power plant" U.S. Department of Energy, Drexel University, Chestnut St. Philadelphia, 2009.
- S. Tuukkanen, J.J. Toppari, A. Kuzyk, P. Törmä. "Dielectrophoresis as a tool for nanoscale DNA manipulation" International Journal of Nanotechnology, Jyväskylä, Finland. 2005, Vol. 2(3) pp. 280-291.
- K. Mehti, S. Park, D. P. Sureh, B. Alli. "Negative dielectrophoretic capture of bacterial spores in food matrices" Biomicrofluidics. American Institute of Physics. Norfolk Virginia, 2010
- M. Bocchi, E. Franchi, R. Guerrieri. "Electronic Microsystems for Handling Rare Cells" IEEE Journal & Magazines. 2010. Vol. 57(1):244-255.
- R. Jan, T. D. Thanh, E. Ralf, A. Dario, R. Alexandra. "Dielectrophoretic Manipulation of DNA: Separation and Polarizability" Analytical chemistry, Bielefeld University, Bielefeld Germany, 2007, Vol. 79(10), pp. 3925-3932.
- R. Hölzel, F.F. Bier "Dielectrophoretic manipulation of DNA" Journal IEEE Proc-Nanobiotechnol. 2003 Vol. 150(2)
- A.T. Giannitsis "Usage of a microfluidic lab-on-chip in biomedicine" 12th Biennial Baltic Electronica Conference, Tallin Technical University, Tallin Estonia. 2010.
- N. Pamme, "Continuous flow separations in microfluidic devices" Lab on a Chip, The University of Hall, Cottingham Road UK, 2007, Vol. 7(12) pp. 1644-1659.

# DETERMINING THE PREFERENCES OF A SOCIAL GROUP STATISTICALLY AND DYNAMICALLY

*Kamal Taha, PhD*  
Khalifa University, UAE

---

## Abstract

In this paper, we propose a group-based Collaborative Filtering framework. The framework uses ontology-driven social networks, where nodes represent social groups. A social group is an entity that defines a group based on demographic, ethnic, cultural, religious, age, or other characteristics. In the proposed framework, query results are filtered and ranked based on the preferences of the social groups to which the user belongs. If the user belongs to social group  $G_x$ , results will be filtered based on the preferences of  $G_x$ . The framework can be used for various practical applications, such as Internet or other businesses that market preference-driven products. In the proposed framework, the preferences of a Social Group can be acquired statically from *hard-copy* published studies about the Social Group or can be acquired dynamically from Web pages that publish information about the Social Group. We describe and experimentally compare the above mentioned approaches.

---

**Keywords:** Personalized search systems, group profiling, collaborative filtering

## 1. Introduction:

Traditional search engines typically return identical results for the same query, independent of the user or the context. Conventional quantitative scoring functions may not adequately reflect users' preferences, since the same document may be queried by users, whose preferences differ. By analyzing search behavior, it is possible to see that many users are not able to accurately express their needs in exact query terms [Micarelli et al. 2006]. In contrast to conventional search engines, a personalized search engine [Keenoy and Levene 2005, Carmine and Antonio 2003, Weihua 2002] would return different results for the same query, depending on the user and the context. Profiles can modify the representation of the user needs before the retrieval takes place. Most personalized systems lean towards being Information Filtering (IF) systems more than being general Information Retrieval (IR) systems [Oard 2007].

Most existing personalized search systems do not consider group profiling. Group profiling can be an efficient retrieval mechanism, where a user profile is inferred from the profile of the social groups to which the user belongs. In this paper, we propose a framework that determines the preferences of Social Groups. The framework categorizes Social Groups based on demographic, ethnic, cultural, religious, age, or other characteristics. For example, people of ethnic group  $E_X$ ; people who follow religion  $R_Y$ ; and people who live in neighborhood  $N_Y$  can all be considered to form various social groups. In social communities, it is commonly accepted that people who are known to share a specific background are likely to have additional connected interests [Herlocker et al. 2002]. The framework can be used for various practical applications, such as Internet or other businesses that market preference-driven products. In the proposed framework, the preferences of a Social Group could be identified from either: (1) the preferences of its member users, or (2) from published studies about the social group (the availability of such data has had a significant boost with the emergence of the World Wide Web).

By crawling Web sites, the proposed framework initializes the preferences and ratings of Social Groups dynamically from Web pages that publish information about them. We proposed previously in [Taha and Elmasri 2010b] an approach that identifies the semantic relationships between XML elements in an XML document. We describe in this paper modifications we made to [Taha and Elmasri 2010b] to suit the extraction of Web content data for the sake of dynamically initializing Social Groups' preferences. We also describe modifications we made to an approach proposed in [Tang 2008] in order to initialize a Social Groups' preferences. The system generates items' scores by converting the preference data (obtained from the two approaches) into weighted web-feature and feature-item matrices.

## 2. Initializing the ratings of a Social Group Statically

The preferences of a Social Group can be acquired statically from *hard-copy* published studies such as:

- a) Published articles and books (e.g., [Kittler 1995; Tesoro 2001]).
- b) Published studies conducted by organizations (e.g., [FAQ Archives 2008]), or specialized centers belonging to universities.

First, we need to decide on the publications to be used. The more publications used, the more accurate the results are. We need to select ones issued by reputable sources. Preferences on an item's features obtained from a hard-copy published study are represented as a publication-feature matrix  $M$  with entries  $f_i$  and  $P_j$ : feature  $f_i$  is recommended by publication  $P_j$ . The rating of publication  $P_j$  on feature  $f_i$  is the element  $M(j, i)$  of matrix  $M$ . Element  $M(j, i)$  is a Boolean value, where *one* denotes that publications  $P_j$  stresses the importance of feature  $f_i$  to the Social Group and *zero* otherwise. That is, the rating  $M(P_j)$  of publication  $P_j$  is the  $j$ -th row of matrix  $M$ . For example, consider the following *car* preferences of the residents of neighborhood  $N_x$  (i.e., Social Group  $N_x$ ).  $N_x$  is a neighborhood in the State of Minnesota, USA. According to published surveys, 68% of Minnesotans prefer cars with *snow-proof* features<sup>1</sup>, 61% prefer *fuel-efficient* cars<sup>2</sup>, and 76% of the residents of  $N_x$  prefer *cost-efficient* cars<sup>3</sup>. The preferences of  $N_x$  on each of these three features will be assigned a weight of *one* in matrix  $M$ . The score of a feature is the *summation of publications' weights on it* (see Equation 1). Table 3 shows an example data set of matrix  $M$ . For example, the score of feature  $f_1$  is the sum of the weights of publication  $P_2$ ,  $P_3$ , and  $P_5$  on feature  $f_1$ .

$$\text{Score } f_i = \sum_{j=1}^{|I|} M(P_j, f_i) \quad (1)$$

We now introduce an item-feature matrix  $N$ , where element  $N(j, i)$  is *one*, if item  $I_j$  contains feature  $f_j$  and *zero* otherwise. The profile  $N(I_j)$  of item  $I_j$  is the  $j$ -th column of matrix  $N$ . The score of item  $I_j$  is the *summation of the normalized scores* of the features that  $I_j$  contains (see equation 2)

$$\text{Score } I_j = \sum_{\forall N(f_i, I_j)=1} \text{score } f_i \quad (2)$$

## 3. Employing the XCDSearch Approach in [Taha and Elmasri 2010b] for Initializing the Ratings of a Social Group from Web Pages Dynamically by Crawling Web Sites

We proposed in [Taha and Elmasri 2010b] techniques called XCDSearch to build *semantic relationships* between elements in XML documents. For the sake of this work, we modified these techniques in order to build semantic relationships between Web content data (i.e., *instead of XML data*) to initialize the ratings of Social Groups. We constructed a

<sup>1</sup> Due to the very snowy winter in the state of *Minnesota*.

<sup>2</sup> Which is due, in part, to the fact that the government of *Minnesota* offers sales tax break incentive for buying fuel-efficient cars.

<sup>3</sup> Due to the fact that  $N_x$  is a middle-class neighborhood (e.g., [Minneapolis Census 2000]).

prototype that employs these techniques to dynamically identify the preferences of Social Groups from Web pages that publish information about them. The system will then generate items' scores *dynamically* by converting this preference data to weighted *web-feature and feature-item matrices* using equations 1 and 2. The system will use these matrices to *initialize* Social Groups' ratings. First, the system will mark up a Web page with XML tags and model the resulting document as a rooted and labeled XML tree (e.g., Fig. 1). A Social Group is represented as an interior node in the XML tree, and its preferences as data/leaf nodes. For example, Fig. 1 is a fragment of an XML tree modeling the content data of Web page publishing information about some Social Groups.

We first define key concepts used in the modified techniques. We use the term Ontology Label to refer to the ontological concept of a node in an XML tree. Let ( $m$  "is-a"  $m'$ ) denote that class  $m$  is a subclass of class  $m'$  in an Object-Oriented ontology.  $m'$  is the most general superclass (root node) of  $m$  in a defined ontology hierarchy.  $m'$  is called the Ontology Label of  $m$ . The system converts an XML tree into a tree called ontology-based tree. For example, Fig. 2 shows an ontology-based tree constructed from the XML tree in Fig. 1. An ontology-based tree is constructed as follows. First, the system removes all interior nodes that do not have children data nodes (for example, nodes 4, 7, and 13 are removed from Fig. 1). Then, the system replaces the remaining interior nodes with their Ontology Labels (for example, nodes ethnic group(1) and sect(8) in Fig. 1 are replaced by their Ontology Label, which is GROUP as shown in Fig. 2).

Let  $a$  be an interior node and  $b$  a data node in an ontology-based tree. Nodes  $a$  and  $b$  are *semantically related* if the paths from  $a$  and  $b$  to their *Lowest Common Ancestor (LCA)*, not including  $a$  and  $b$ , do not contain more than one node with the same Ontology Label. The LCA of  $a$  and  $b$  is the only node that contains the same Ontology Label in the two paths to  $a$  and  $b$ . Consider that node  $b$  contains the preference data<sup>4</sup>  $P_i$  and that node  $a$  represents Social Group  $G_j$ . If nodes  $a$  and  $b$  are semantically related,  $P_i$  is a preference of Social Group  $G_j$ . For example, consider Fig. 2. Preference "no pork-related products" (node 10) belongs to religious sect  $R_Y$  (node 6) and not to ethnic group  $E_X$  (node 2), because the LCA of nodes 10 and 2 is node 1, and the path from node 1 to node 10 includes two nodes with the same Ontology Labels (i.e., nodes 1 and 8). Similarly, the preference "spicy flavor" (node 3) belongs to  $E_X$  and not to  $S_Z$  (node 9). Using the same techniques, both of "spicy flavor" and "no pork-related products" are preferences to religion group  $R_Y$  (node 6).

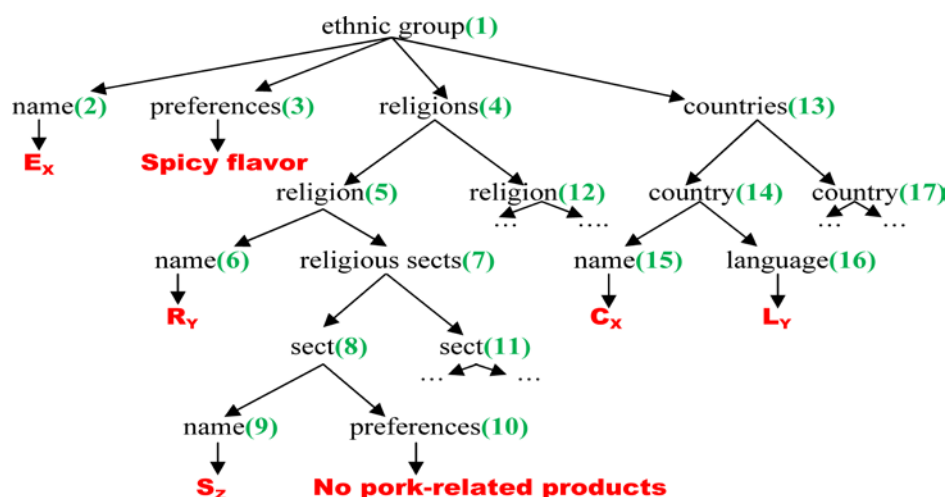

Fig. 1. A fragment of an XML tree modeling the content data of a Web page about some Social Groups. Nodes are numbered for easy reference.

<sup>4</sup> The system identifies such data via *text mining program*



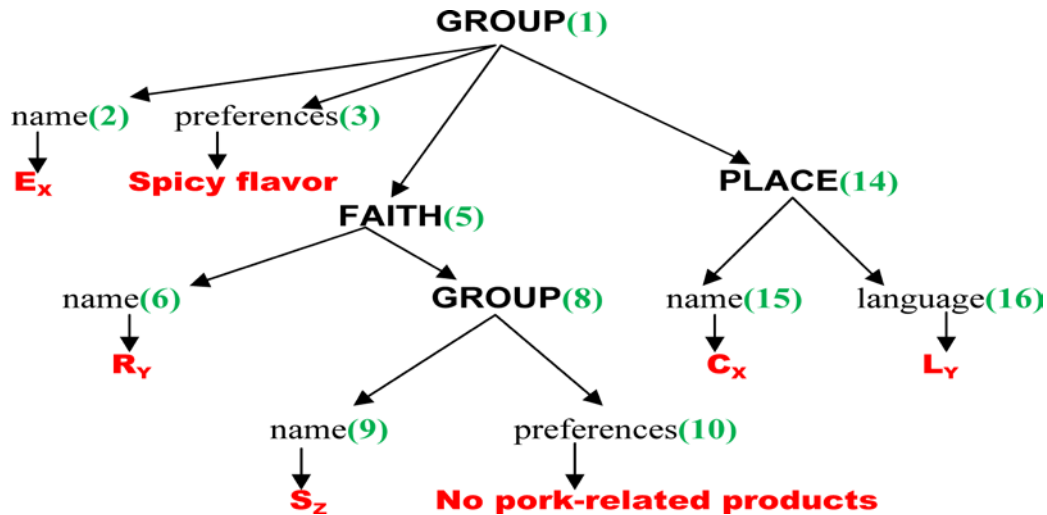

Fig. 2. Ontology-based tree constructed from the XML tree in Fig. 1

#### 4. Employing the TopDown Approach in [Tang 2008] for Initializing the Ratings of a Social Group from Web Pages Dynamically by Crawling Web Sites

[Tang 2008] studies the effect of *topic taxonomy* on dynamic *group profiling*. A topic taxonomy consists of topic nodes. Each internal node is defined by its vertical path (*i.e., ancestor and child nodes*) and its horizontal list of attributes. To perform taxonomy adaptation, the paper proposes a top-down hierarchical traversal approach called TopDown. We constructed a prototype that employs an *adjusted* version of the TopDown approach to identify and initialize the preferences of a Social Group from Web pages publishing information about it. For each topic node  $n$  representing a Social Group  $G_x$ , this copy of the prototype identifies the *best neighbor* nodes of  $n$  that contain preference data about  $G_x$ . The TopDown approach consists of multiple iterations to search for *better hierarchies*, as follows:

1. *Identification of the node to check*: A list of topic nodes in the hierarchy is maintained for the search. Nodes at the upper level are given higher priority.
2. *Identification of promising neighboring hierarchies concerning a node*: The promising hierarchies are checked by *rolling-up nodes* to their upper level. Then, the hierarchies are checked by *pushing down nodes* to their siblings and by *merging* two sibling nodes to form a super node.
3. *Identification of the best neighbor*: This procedure compares all the promising neighboring hierarchies and finds the best among them.
4. *Update of the current best hierarchy*: The current best hierarchy is replaced with the best hierarchy just found and the list of nodes to check is updated.

**Example 2:** Consider that the system crawled a website publishing information about the Buddhism faith and identified the classificatory taxonomy of branches shown in Fig. 3. In the figure,  $p_x$ ,  $p_y$ ,  $p_z$ , and  $p_w$  are preference data. By *merging* nodes Mandalas and Shingon and *rolling up* the resulting node, and by *pushing down* node Mahayanists, the preferences of the Mahayanists can be identified as  $p_x$ ,  $p_y$ , and  $p_z$ . By *pushing down* node Buddhists, it preferences can be identified as  $p_x$ ,  $p_y$ ,  $p_z$ , and  $p_w$ .



Fig. 3. Classificatory taxonomy of branches of the Buddhism faith

## 5. Experimental Results

### 5.1 Test Data for Real-User Evaluation

We asked 32 students from The University of Texas at Arlington (UTA) to evaluate and compare the four systems. The students belong to four different ethnic backgrounds and five ancestry origins. Some of them consider religion to be irrelevant and the others follow three different religions. We asked each of the students to prepare a list of 10 canned food items *ranked* based on the student's *own preferences*. We then asked this student to query our prototype systems for canned food to determine which one(s) returns ranked list of canned food *matches closely* to the one ranked by the student himself/herself.

### 5.2 Comparing Three Approaches for Initializing the Ratings of a Social Group

We compare in this test the three approaches described previously for *initializing* the preferences and ratings of a Social Group. These approaches are: (1) the *static initialization* from *hard-copy* published studies, (2) the *dynamic initialization* using the modified version of XCDSearch [Taha and Elmasri 2010b], and (3) the *dynamic initialization* using the modified version of TopDown [Tang 2008]. We cloned the prototype system into three identical copies, each employing one of the three approaches described above. Our objective is to determine which one of the three copies gives ranked lists of canned food *closest* to those ranked by the subject users. For the experimental dataset, we selected 18 Web sites publishing information about social groups and their preferences. For the sake of consistency, we used the same dataset for evaluating the static initialization approach also (*rather than using published hard copies*).

We ran the Web pages (*dynamically*) against each of the two copies employing the *dynamic approaches*. As for the copy employing the *static initialization* approach, we entered the preference data from the Web pages *manually* into the copy. We then measured the distance  $d(\sigma_u, \sigma_s)$  between each list ranked by a resident  $u$  and the corresponding list ranked by one of the three copy systems  $s$ , using the following Euclidean distance measure.

$$d(\sigma_u, \sigma_s) = \sum_{x \in X} | \sigma_u(x) - \sigma_s(x) | \quad (3)$$

$X$ : Set of canned food items.

$\sigma_u \in [0,1]^{|X|}$ : List of items ranked by resident  $u$ .

$\sigma_s \in [0,1]^{|X|}$ : A list ranked by *one of the three copy systems*

$\sigma_u(x)$  and  $\sigma_s(x)$ : *position* of canned food item  $x \in X$  in the lists  $\sigma_u$  and  $\sigma_s$  respectively (*a ranking of a set of  $n$  items is represented as a permutation of the integers  $1, 2, \dots, n$* ).

Intuitively, the *static initialization approach* is expected to be more accurate than the other two approaches, since data is entered to the system *manually*. However, we aim at studying: (1) how much less accurate are the dynamic approaches than the static approach and *whether this accuracy difference is significant*, (2) whether the *practicality and convenience* of the dynamic approach makes up for its lower accuracy, in case the accuracy difference is not significant, and (3) the impact of *number of publications* on the accuracy of the three approaches. Fig. 4 shows the results. We can infer from the results the following:

- (1) The static approach outperforms the two dynamic approaches as long as *the number of publications is less than about 25*.
- (2) The XCDSearch's approach outperforms the TopDown approach *as long as the number of publications is greater than about 10*.

Based on the experiment results, we advocate employing the XCDSearch's approach for the sake of practicality and dynamicity, especially for recommender systems that target a rather wide range of Social Groups.

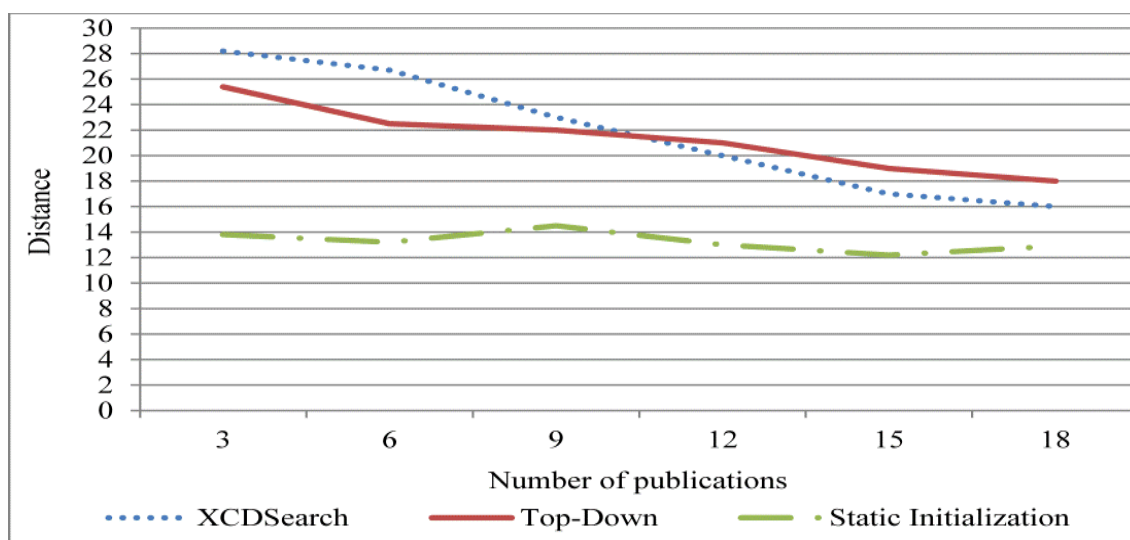

Fig. 4. Distance between the lists of items ranked by the subject users and the lists ranked by the prototypes employing the XCDSearch, TopDown, and static initialization approaches

## 6. Conclusion:

In this paper, we proposed a group-based Collaborative Filtering framework. The framework uses ontology-driven social networks, where nodes represent social groups. A social group is an entity that defines a group based on demographic, ethnic, cultural, religious, age, or other characteristics. The framework can be used for various practical applications, such as Internet or other businesses that market preference-driven products. In the proposed framework, the preferences of a Social Group can be acquired statically from *hard-copy* published studies about the Social Group or can be acquired dynamically from Web pages that publish information about the Social Group.

We experimentally compared the approach of determining the preferences of a Social Group statistically from published studies with the approach of determining these preferences dynamically from Web pages. Based on the experiment results, we advocate the approach of determining the preferences dynamically from Web pages for its practicality and dynamicity, especially for recommender systems that target a rather wide range of Social Groups.

## References:

- Carmine, C., Antonio, P. An Intelligent Search Agent System for Semantic Information Retrieval on the Internet. *WIDM'03*
- Herlocker, J. L., Konstan, J. A., and Riedl, J. "Explaining Collaborative Filtering Recommendations". Proc. of the ACM Conference on Computer Supported Cooperative Work, 2002
- FAQ Archives (2008). *Religion and Dietary Practices*. Available: <http://www.faqs.org/nutrition/PreSma/Religion-and-Dietary-Practices.html>
- Keenoy, K. and Levene, M. 2005. Personalization of Web Search. *Lecture Notes in Computer Science*, 3169.201-228.
- Kittler, P. 1995. *Food and culture in America: A nutrition handbook*. West Publishing, Redding.
- Minneapolis Census (2000). Selected Economic Characteristics by Neighborhood, city of Minneapolis. <http://www.ci.minneapolis.mn.us/citywork/planning/Census2000/maps/economic/>
- Micarelli, A., Gasparetti, F., Biancalana, C. 2006. *Intelligent Search on the Internet*. Reasoning, Action and Interaction in AI Theories and Systems. LNCS, ISSN 0302-9743, Vol. 4155.

- Oard, D. W. The state of the art in text filtering. *User Modeling and User-Adapting on the internet, Springer 7*, 141-178.
- Taha, K., and Elmasri, R. "SPGProfile: Speak Group Profile." *Information Systems (IS)*, 2010, Elsevier, Vol. 35, No. 7, pp. 774-790
- Taha, K., and Elmasri, R. "XCDSearch: An XML Context-Driven Search Engine". *IEEE Transactions on Knowledge and Data Engineering (TKDE)*, 2010, Vol. 22, No. 12, pp. 1781-1796.
- Tang, L., Liu, H., Zhang, J., Agarwal, N., Salerno, J. Topic Taxonomy Adaptation for Group Profiling. *ACM Transactions on Knowledge Discovery from Data*, 2008, Vol. 1, No. 4.
- Tesoro, E. (2001). *Religious Determinants of Food Choices*.
- Weihua, L. Ontology Supported Intelligent Information Agent. *International IEEE Symposium On Intelligent Systems'02*

# PROPOSING A REAL TIME INTERNAL INTRUSION DETECTION SYSTEM TOWARDS A SECURED DEVELOPMENT OF E-GOVERNMENT WEB SITE

*Al-Khanjari, Z.*

*Alanee, A.*

*Kraiem, N.*

*Jamoussi, Y.*

Department of Computer Science, College of Science,  
Sultan Qaboos University, Muscat, Oman

---

## Abstract

As society becomes more and more reliant on software systems for its smooth functioning, software security is emerging as an important concern to many researchers in the field of Computer Science. We describe a prototype implementation based on the internal sensors to perform internal intrusion detection in e-Government website. The internal sensors consist of code source added to the e-Government website inside ISP where monitoring will take place. It shows check for specific conditions that indicate an attack is taking place, or an intrusion has occurred in a real time to building internal intrusion detection systems. These systems are based on internal sensors and classification of data collection mechanisms for intrusion detection systems. It shows that it is possible to build e-Government website which is able to detect different types of intrusions and places of implementation that are most effective in detecting different types of attacks. In this paper, we introduce the work that will attempt to show that it is possible to perform real time internal intrusion detection using small sensors embedded in e-Government website source. These sensors will look for signs of specific intrusions and will perform target monitoring by observing the behavior of the website directly in real time. In this work we speak about the image file and how to protect it.

---

**Keywords:** E-government, IDS, software engineering, sensors and detectors

## 1. Introduction

An intrusion detection system is an important component to enhance security in e-Government website. The security environment in e-Government website differs from other websites that are used for browsing the internet. Therefore, more exposed to threats and the Attacks on computer infrastructures are becoming an increasingly serious problem nowadays in e-Government. Hence, several information security techniques are available today to protect the e-Government infrastructures. In order to achieve the security goal, a set of security services in e-Government should be implemented. These services include deterrence, prevention, detection, and protection in real time. Historically, the detection technology dated back to 1980. Anderson [1] introduced the concept of intrusion detection. Anderson proposed a “security surveillance system” involving formal examination of a system’s audit logs. In examining the system threats, Anderson also introduced the notion of categorizing intruders based upon their access to a system, and he defined the internal intruders with permissions to access the system and external intruders without any permission.

A wireless sensor networks for intrusion detection application is capable of detecting any physical existence of external intruder [2]. Katneni and colleagues considered scenarios where traditional methods of sensor deployment do not perform well with regard to intrusion

detection at the boundary of an area under protection. Katneni proposed a Hybrid Gaussian-Ring Deployment that provides a higher intrusion detection probability with fewer nodes for attacks at the edge of the network [3]. Wilkerson and colleagues applied Random sensor deployments following Poisson or Gaussian distribution are the most widely adopted deployment strategies for hostile and unpredictable application scenarios such as environment surveillance and malicious mobile target detection [4].

E-Government refers to the use of information technologies like wide area network by government agencies. The internet and mobile computing that have the ability to transform relations with citizens, businesses. Haque [5] focused on exploring the Grid Framework for the e-Government communication and collaboration system. Zisis and colleagues [6] explore increasing participation and sophistication of electronic government services, through implementing a cloud computing architecture. Zhou and colleagues [7] stated that security risk management analyzes the procedures of e-Government security risk management from three aspects: risk identification, risk analysis and risk control. The corresponding countermeasures were proposed. Unfortunately, most of the work in e-Government security is kept as secrets of countries and is not published. In this paper, we advocate improving the embedded sensors for real time internal intrusion detection system. This involves adding code to the e-Government website where monitoring will take place. The sensors check for specific conditions that indicate an attack is taking place, or an intrusion has occurred. Embedded sensors have advantages over other intruder detection techniques (usually implemented as separate processes) in terms of reduced host impact, resistance to attack, efficiency and effectiveness of detection.

We describe the use of embedded sensors in general, and their application to the detection of website attacks to protect Image file in e-Government website. The Design and development of the sensors have been done in the real website hosting. Our tests show a high success rate in the detection of the attacks.

The work we propose is divided in four stages:

1. Designing infrastructure for the development of the sensors,
2. Implementing sensors for detecting intrusions,
3. Performing analysis on the data obtained in step (2) and validating if the existing sensors can be used to detect new attacks,
4. Connecting to other ISP to open same e-Government website.

This paper proposes a method to detect internal intrusion for protecting e-Government website using Java language. This is done by dealing with the classes of the HTML file. This file contains all programmable steps to detect internal intrusion and protect all files, which deal with that site from unauthorized changing by an intruder inside ISP. Automatic audit for all files provides high security to the site protection without using any other protection programs. These programs might be used to detect intruder inside e-Government website in ISP. With this method we can protect all files, which are dealing with the e-Government website, and automatically check for all files inside class file. This method differs from other methods by not providing the program code inside the HTML file. Therefore, it is difficult to discover and analyze the proposed method because it is inside the class file.

By using real time technique, we can use our method to detect internal intruder and protect all kinds of files inside e-Government website and all those which deal with them without returning to or getting the help of the ISP and without stopping the site for service in case of intrusion through operating an alternative site from another ISP.

The rest of the paper is organized as follows. Section 2 explains the Intrusion Detection System (IDS) and the difference between Intruder and Intrusion. Section 3 discusses some of the Sectors and Stages of e-Government and the Barriers and Challenges of e-Government. Section 4 describes the purpose of the development of the sensors and provides the meaning of Sensors and Detectors. It also describes Embedded Sensors for Intrusion Detection. This is

followed by providing the main Functions of the Proposed System and the infrastructure of the internal embedded sensor. Section 5 provides concluding remarks of the work. Section 6 presents our suggestions for future work.

## 2. Intrusion Detection

Intrusion detection has been defined as “the problem of identifying individuals who are using a computer system without authorization (i.e., ‘crackers’) and those who have legitimate access to the system but are abusing their privileges (i.e., the ‘insider threat’) [8]. Intrusion detection and assessment systems are an integral part of any physical protection system. Detection and assessment provide a basis for the initiation of an effective security response. Intrusion Detection Systems (IDSs) should be designed to facilitate the detection of attempted and actual unauthorized entry into designated areas and should complement the security response by providing the security force with prompt notification of the detected activity from which an assessment can be made and a response initiated [9].

**2.1 Intruder:** A person who is the perpetrator of a computer security incident often referred to as hackers or crackers. An intruder is a vandal who may be operating from within the boundaries of an organization or attacking it from the outside [10]. There are two types of intruders [11]:

- External Intruders who have no authorized access to network resources.
- Internal Intruders who have authorized access to network resources.

**2.2 Intrusion:** Intrusion is the set of actions that attempts to compromise integrity, confidentiality or availability of network resources; while an intruder is any user or group of users who initiates such intrusive action [11]. Intrusion generally refers to unauthorized access by outside parties, whereas misuse is typically used to refer to unauthorized access by internal parties [12].

### 2.3 Intrusion Detection System (IDS)

An Intrusion Detection System (IDS) is a device or software application that monitors network or system activities for malicious activities or policy violations and produces reports to a management station [13]. IDS perform a variety of functions as shown in Figure 1.

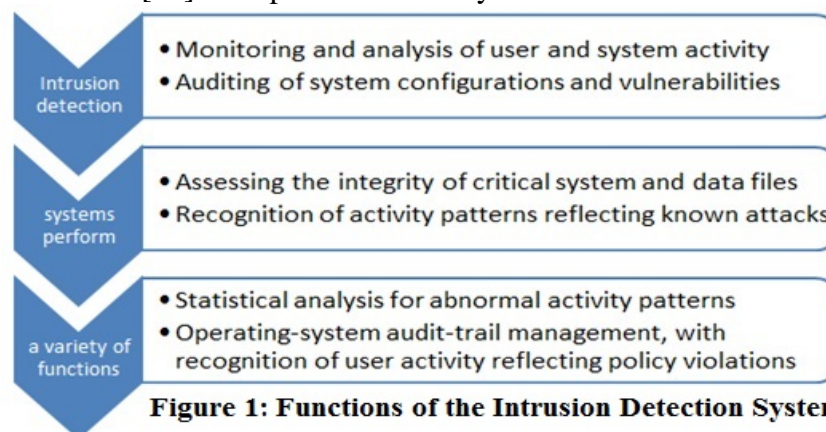

**Figure 1: Functions of the Intrusion Detection System**

## 3. E-Government

E-Government is also known as a digital government, online government or in a certain context transformational government refers to government’s use of information and communication technology (ICT) to exchange information and services with citizens and businesses. E-Government may be applied by legislature, judiciary or administration in order to improve internal efficiency, the delivery of public services, or processes of democratic

governance. The primary delivery models are Government-to-Citizen (G2C), Government-to-Business (G2B) and Government-to-Government (G2G) [14].

### 3.1 Sectors of E-Government

Although e-Government encompasses a wide range of activities and actors, three distinct sectors can be identified. These include government-to-government (G2G), government-to-business (G2B), and government-to-citizen (G2C). Some observers also identify a fourth sector, government-to-employee (G2E).

#### 3.1.1 Government-to-Government (G2G)

In many respects, the G2G sector represents the backbone of e-Government. Some observers suggest that governments (federal, state, local) must enhance and update their own internal systems and procedures before electronic transactions with citizens and businesses can be successful [15].

#### 3.1.2 Government-to-Business (G2B)

Government-to-Business (G2B) initiatives receive a significant amount of attention, in part because of the high enthusiasm of the business sector and the potential for reducing costs through improved procurement practices and increased competition [16]. The G2B sector includes both the sale of surplus government goods to the public, as well as the procurement of goods and services. Although not all are directly dependent on the use of information technology, several different procurement methods are used in relation to the G2B sector [17].

#### 3.1.3 Government-to-Citizen (G2C)

The third e-Government sector is Government-to-Citizen (G2C). G2C initiatives are designed to facilitate citizen interaction with government, which is what some observers perceive to be the primary goal of e-Government. These initiatives attempt to make transactions, such as renewing licenses and certifications, paying taxes, and applying for benefits, less time consuming and easier to carry out [18].

### 3.2 Stages of E-Governance

In order to accomplish e-Government initiatives, there must be a phased approach applied to the infrastructure Development which transforms an initial e-Government initiative into final desired service. There are four stages of e-Government, which in most cases follow each other [19]: Figure 2 demonstrates Stages of e-Governance.



Figure 2: Stages of e-Governance

**Integration of Services:** This is the highest level of any e-Government where technology is utilized to its full potential [20].

**Complete Transaction over Web:** The stage involves transaction between a citizen and government being completed over the internet.

**Interaction between Citizen and Governments:** The second stage is marked by the presence of an interactive web interface where some kinds of communication occur between government and its citizens through the web.

**Presence on the Web:** The first stage on any e-Government is marked by its presence on the web which acts as a common place for distributing information to the public. It is the most basic part of any e-Governance system and has limited capabilities.



### 3.3 Barriers and Challenges of E-Government

According to case studies from different countries, there are many challenges and issues that need to be addressed for successful implementation of e-Government. Security and privacy of information are other serious technical challenges. Challenges are identified as follows: [21]

IT Infrastructural weakness plus Lack of qualified personnel and training courses

Lack of knowledge about the e-Government program

Lack of security and privacy of information plus Lack of strategic plans

Lack of policy and regulation for e-usage and Lack of partnership and collaboration

Resistance to change to E-Systems as well as the shortage of financial resources

### 4. Purpose of the Development of the Sensors

We discuss the development of the sensors and the results obtained to protect Class and Image file in e-Government website. The two hypotheses that underlined in this paper are practical in nature. **First**, they intend to show that it is feasible to build an intrusion detection system in e-Government website using both internal sensors and embedded detectors. **Second**, it can be used to detect both known and new attacks.

The internal embedded sensor was also used to confirm the possibility to building e-Government website security. Therefore, Designing infrastructure for the development of the sensors e-Government website was a center point for the development of this paper.

#### 4.1 What are Sensors and Detectors?

Internal sensors and embedded detectors. An internal sensor is a piece of code built into e-Government website that monitors a specific variable or condition of that site. By being built into the program that it is monitoring, an internal sensor can perform direct monitoring on the system, which allows it to obtain information that is reliable (very difficult to modify) and real-time (obtained almost at the moment it is generated). An embedded detector is a piece of code built into e-Government website that looks for specific signs of specific attacks or intrusions. An embedded detector bases its decisions on an internal sensor, explicitly (when the sensor is clearly differentiable from the detector). Embedded sensors operate in a different manner in comparison to other intrusion detection systems. The sensors are themselves resistant to attack. They are also effective in detecting attacks in real-time with minimal impact on website performance.

#### 4.2 Embedded Sensors for Intrusion Detection

An embedded sensor is defined as a piece of code in e-Government website that monitors a specific variable, activity or condition of a host. Because the sensor monitors the system directly (real-time) and not through an audit trail or through packets on a network, we say that it performs direct monitoring, and because the sensor is part of the e-Government website program or system it monitors, it is said that it is an internal sensor.

Embedded sensors are built by modifying the source code of the program that will be monitored. Sensors should be added to the code at the point where a security problem can be detected in the most efficient way by using the data available at that moment.

#### 4.3 The Main Function of the Proposed System

The proposed system operation started by initializes the request signal of website through internet browser for controlling the e-Government website inside ISP. After initialization stage; the proposed system starts the check collection information about the site. The first stage checks the watermark inside the e-Government website. The information about copyright protection will be detected and analyzed for accepting to check other files in e-Government website before opening it. The internal embedded sensor receives the request and tries to detect any threats inside ISP. If there is an attack, then the internal embedded sensor

will try to stop this attack by sending signal to other ISP to open the same e-Government website and sending Email to the administrator or the supervisor site, which contains a changed file. The main stages of the internal embedded sensor are:

### 1. Initialization Stage:

Initializing the request signal of e-Government website through internet browser

Checking the watermark or copyright protection

Initializing the analysis phase

### 2. Analyzing Stage:

Analyzing Image file

Analyzing HTML file

Figure 3 shown the basic flowchart of the proposed system

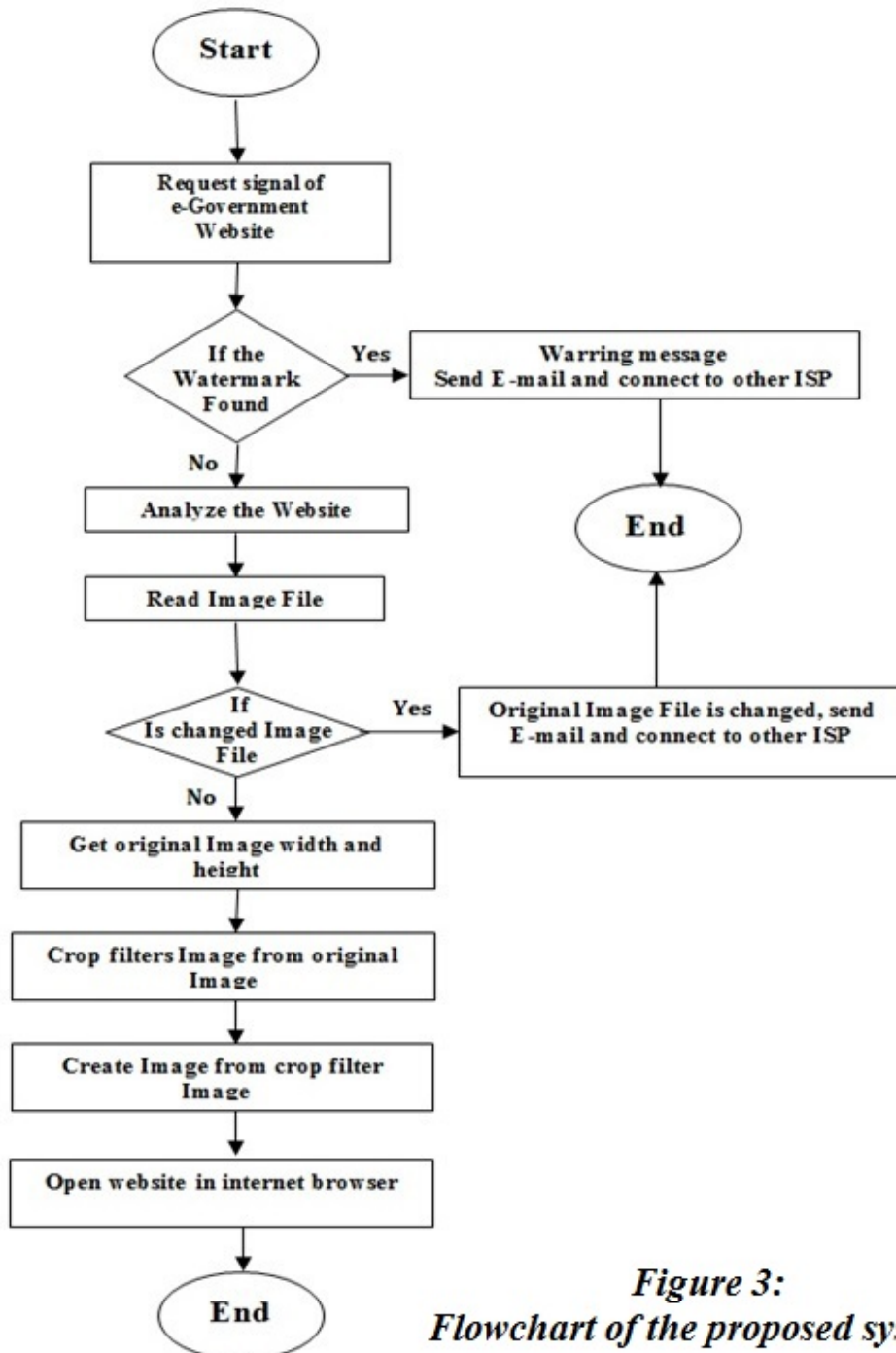

**Figure 3:**  
*Flowchart of the proposed system*

### 4.3.1 Check Image File

After determining the initialization stage and checking watermark (copyright protection) of the proposed system put the second stage to check each file. Generally the basic flowchart of the proposed system, that checks Image file, is as shown in Figure 4.

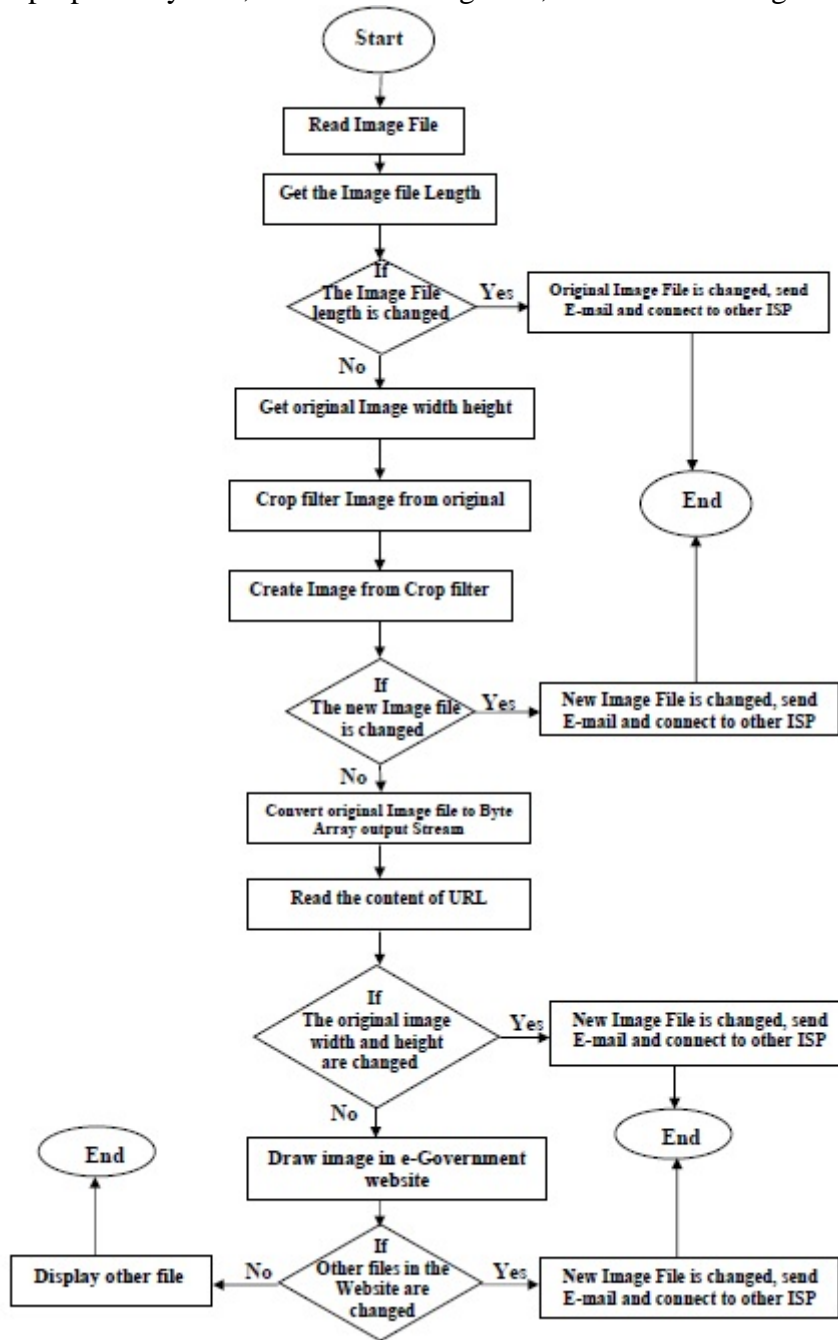

Figure 4: Flowchart of the Proposed System that checks Image File

### 4.4 Infrastructure Internal Embedded Sensor

The main aim of the proposed system is to design real time internal intrusion detection in website to detect the intruder that tries to attack the website. The first step of the working proposed system is start up checking the watermark (copyright protection) as sending parameter from HTML file to Class file like `<PARAM name="copyright"`

`Value=" Sultan Qaboos University - Computer Science Department20 13 ">`

Figure 5 shows the HTML file code. The method code of copyright protection is:

```

public void init(){ public String copyright = " Sultan Qaboos University - Computer Science Department 2013";String copyrightParam = getParameter("copyright")if
    
```

```
((copyrightParam == null) || !copyrightParam.equals(copyright)) { throw new
SecurityException("Thank you to maintain the original copy of the change (Sultan
Qaboos University - Computer Science Department 2013)");}
```

```
File Edit Format
1 <HTML>
2 <HEAD>
3
4 <TITLE>" Sultan Qaboos Uinversity </TITLE>
5 </HEAD>
6 <BODY>
7
8 <applet code="Squ.class" width=250 height=250>
9 <PARAM name="copyright" value="Sultan Qaboos University - Computer Science Department 2013 ">
10 </applet>
11
12 </BODY>
13 </HTML>
14
```

**Figure 5: HTML File Code**

The proposed system will check other files step by step. After checking the watermark copyright protection the system will check Image file. Figure 6 shows the original image file and crop filter Image from original image.



**Figure 6:**  
**The Original Image File and**  
**Crop Filter Image from**  
**Original Image**

If Image has been changed, then the proposed system will send Email to supervisor site and Security Officer and send signal to other ISP to open same e-Government website.

The method of connect to other ISP is

```
squ = new Site (" Same site ", "http://www.test.com/squ.html");public Site( String siteTitle,
String siteLocation ) { title = siteTitle; try {location = new URL( siteLocation );} catch (
MalformedURLException e ) { System.err.println( "Invalid URL: " + siteLocation ); }
```

#### 4.5 Advantages of Embedded Sensors in E-Government Website

Using embedded sensors for e-Government website in an internal intrusion detection system has the following advantages over using external sensors (implemented as separate programs):

Data in the website is never stored on an external medium before the sensor obtains them. Therefore, the possibility of an intruder modifying the data to hide its tracks.

Embedded sensors are part of the code in e-Government website they monitor.

Therefore, they cannot be disabled (as it is possible with an external sensor, which can be killed or disabled). Also they are coming very difficult to modify to produce incorrect results.

Embedded sensors can analyze the data (at real time). Therefore, reducing impact on the host.

They can obtain data at its source, or at the place where it is more convenient to obtain. Data does not have to traverse through an external program interface for the sensor to get it, because the internal sensor in the website can read it directly off the program's data structures. This reduces the delay between the generation of the data and when the intrusion detection system can make use of it.

Embedded sensors in e-Government website are only executed when the task they perform is required (this is, when the section of code they are a part of is executed). They are not executed as separate processes or threads, but as part of the monitored program of e-Government website.

Embedded sensors in e-Government website can look for very specific conditions that signal attacks, instead of reporting generic data for analysis.

This means that the amount of data that needs to be reported, collected and analyzed by higher level analysis engines is much smaller.

#### **Disadvantages of Embedded Sensors in E-Government Website**

Embedded sensors in the website have the following disadvantages with respect to external sensors:

They are more difficult to implement, because they require modifications to the source code of the e-Government website.

Their implementation requires having access to the source code of the website.

They have to be implemented in the same language as the e-Government website program in which they are being incorporated.

Improperly implemented sensors can have detrimental effects on the performance of the website.

### **5. Conclusion**

This paper proposed an architecture based on using internal sensors built into the source code of the programs that are monitored by real time and able to extract information from e-Government website inside the ISP in which it is generated or used, Furthermore, by expanding those internal sensors with decision-making logic. Also, this paper provides an architectural and practical framework in which future study of internal sensors and embedded detectors in intrusion detection can be based in e-Government website. It also provides a classification of data source types for internal intrusion detection and a description of the characteristics and types of internal sensors and embedded detectors which are used inside e-Government website like image, sound, text, class and HTML file.

The internal sensor is an approach for the development of real time internal intrusion detection in e-Government website and Transition Analysis Technique is used to detect internal intruder in e-Government website.

This Section describes the result of applying the internal sensor in e-Government website to develop an intrusion detection family.

The work supports efficient development of new internal intrusion detection sensors because the main mechanism is used to detect any internal intruder on e-Government website in real time. However, in practice, the design of an internal intrusion detection system may not follow the functional model. In most cases, the designers of the intrusion detection system face constraints imposed by the environment in which the intrusion detection system is going to operate.

We have shown how internal sensors for intrusion detection attacks are used in e-Government website. The following points are concluded from the proposed system.

The excellent detection rate is very encouraging.

The internal sensors have been the simplest in the cases where they embedded themselves in all files on website and checked all attacks.

This internal intrusion detection system can operate without any external components.

The prototype implemented is able to detect previously unknown attacks.

The proposed method detects internal intrusion for protecting an e-Government website using Java language for dealing with the classes.

Using automatic audit for all files provides high security to the site protection without using any other protection programs.

By using the real time technique, we can use our method to detect internal intruder and protect all kinds of files inside e-Government website and all those which deal with them without returning to or getting the help of the ISP and without making the site stops providing service in case of intrusion through operating an alternative site from another ISP.

It cannot attack the e-Government website because the Java applet makes garbage collection to the memory.

The proposed method to detect the internal intrusion and protect files using Java language is very flexible in dealing with any kind of operating systems.

## 6. Suggestions for Future Work

The work presented in this paper has explored the basic concepts of using internal sensors for intrusion detection by showing their feasibility. However, there is a considerable amount of work that needs to be done to further study and characterize their properties. Future work could also explore improving the detection new attacks in data base by implementing internal detectors for a larger number of records inside Database. Another possibility would be the automatic generation of components that could be used by programmers to insert sensors and detectors in their source code.

This paper has explored the feasibility of extracting information about the behavior of a computer system that is more complete and reliable than any data that had been available before to intrusion detection systems. This availability opens multiple possibilities for future exploration and research, and may lead to the design and development of more efficient, reliable and effective intrusion detection systems.

## References:

- Anderson.: Computer Security Threat Monitoring and Surveillance. February 1980.
- Hailong, Pandit, Katneni and Agrawal: A Reverse Gaussian deployment strategy for intrusion detection in wireless sensor, IEEE International Conference, 2012.
- Katneni, Pandit, Hailong and Li, Agrawal: Hybrid Gaussian-Ring Deployment for intrusion detection in wireless sensor networks, IEEE International Conference, 2012.
- Wilkerson, Yun Wang and Xudong Yu : Hybrid sensor deployment for surveillance and target detection in wireless sensor networks, Wireless Communications and Mobile Computing Conference (IWCMC), 7th International, 2011.
- Sirajul Haque and Riaz Memon E-Government using Grid Technology: Developing a Grid framework for G2G E-Communication and Collaboration System, International Journal of Independent Research and Studies IJIRS Vol. 2, No.1, January, 2013.
- Zissis and Dimitrios Lekkas: Securing e-Government and e-Voting with an open cloud computing architecture Government Information Quarterly, Volume 28, Issue 2, April 2011.
- Zhitian Zhou and Congyang : Study on the E-government Security Risk Management, International Journal of Computer Science and Network Security, VOL.8 No.5, May 2008.
- Linda McCarthy ,IT Security: Risking the Corporation", February 24, 2003.
- Intrusion Detection Systems and Subsystems, U.S. Nuclear Regulatory Commission, March 2011.
- Schweitzer: Incident Response: Computer Forensics Toolkit, Wiley Publishing, 2003.
- Ojugo, Eboka, Okonta and Yoro: Genetic Algorithm Rule-Based Intrusion Detection System Journal of Emerging Trends in Computing and Information Sciences VOL. 3, NO. 8 Aug, 2012.
- Kirk Hausman, Diane Barrett and Martin Weiss : Security+ Exam Cram™ 2 April 10, 2003.
- Scarfone, Karen and Mell, Peter : Guide to Intrusion Detection and Prevention Systems (IDPS)". Computer Security Resource, Retrieved 1 January 2010.

Sirajul Haque and Riaz Memon : Developing a Grid framework for G2G E-Communication and Collaboration System , International Journal of Independent Research and Studies – IJIRS , Vol. 2, No.1 ,January, 2013.

Robert Atkinson and Jacob Ulevich, Digital Government: The Next Step to Reengineering the Federal Government, Progressive Policy Institute, March 2000.

Alorie Gilbert: President Bush Backs E-Government, Digital Signatures, 6 April 2001.

Greg Langlois: An Equal Slice of Success,14 May 2001.

William Matthews: Setting a Course for E-Government, 11 December 2000.

SOFIEN BEJI, YASSINE JAMOSSI NABIL EL KADHI :Towards context-awareness security for mobile applications, The International Conference on Service, Security and its Data management technologies in Ubi-com, IEEE, China, October 2010.

Sami M. Alhomod and Mohd Mudasir Shafi: Best Practices in E government: A review of Some Innovative Models Proposed in Different CountriesInternational Journal of Electrical & Computer Sciences Vol: 12 No: 01, 2012.

Nugi Nkwe ,E-Government: Challenges and Opportunities in Botswana Department of Accounting and Finance University of Botswana Gaborone, Botswana International Journal of Humanities and Social Science Vol. 2 No. 17; September 2012.

# IMPROVING THE CITIZEN EXPERIENCE IN THE USE OF MEXICAN GOVERNMENT WEBSITES

*Marta Sylvia del Rio, MSc.*  
Universidad de Monterrey, Mexico

---

## Abstract

Current Mexican government sites lack any common structure, catalogue of services, use of language or information requirements. State sites can be citizen-oriented for a term, and an opposing party might completely change the sites' objectives and become a platform for political propaganda on the next term. The motivation for websites to improve was a ranking recently abandoned. This ranking was focused mostly on technical functionality (chats, calendar, navigation) instead of the use of these tools. This paper describes the most common problems found on sites and explains the need for a new ranking that focuses on the quality of information, the amount of screen space used for functionality and the interaction of citizens with its government departments.

---

**Keywords:** Usability, UX, e-government, Mexican websites, ranking

## Introduction

Usability and accessibility are actually a series of factors that combine and define how simple to use is a website. Among the factors affecting this assessment are as varied elements as user education level, age, the speed of network connection, physical disabilities, familiarity with technology and how well or poorly designed is that interface. We must always bear in mind that the interface must be designed to be easy to use, but above all the information must be easy to find.

Mexican government websites are the reflection of Mexico's government structure. Federal, state, and municipal administrations are independent from each other and can be ruled by opposing parties. Thus, we find that the citizens' experience is very different depending on where you live.

This paper explains the most common problems found and proposes a solution for improving content by creating a new ranking for Mexican government sites.

## Main problems in public service websites

One of the more frustrating problems when navigating government websites is the amount of usability mistakes found. More than that, sites that focus on promotion of public servants tend to make services difficult to access. Another of the greatest problems is the use of complex language and thus lack of understanding.

Some of the most common problems found in websites are described in this article. Don Norman and Jakob Nielsen defined five quality components. These are features that make a significant difference for any user, and in our case, the experience of the citizen. Two additional traits were included to cover the scope of usability issues.

### I. Use of Language

This means no effort is required to understand the information presented. The complexity and ambiguousness of the language used in government sites has caused the Federal



government to endorse a plan called Citizen Language (similar to plain language) to simplify communication so the average citizen can actually understand the information provided.

One of the most problematic sites regarding language is <http://www.cjf.gob.mx/>, where language used is intended for lawyers and judges, and citizens can find searching for information an overwhelming task.

## II. Learnability

Represents the speed at which a user performs a task, accomplished by using a new interface for him. Even if it is the first time a citizen is seeking his identification record in [consultas.curp.gob.mx/CurpSP](http://consultas.curp.gob.mx/CurpSP), it's unlikely they have trouble finding it. The message "Printing the CURP in bond paper is valid for all proceedings for the Public Administration" also helps.

On the other hand, security codes to pay taxes are extremely hard to find in [www.satgob.mx](http://www.satgob.mx). Even if the citizen finds instructions to generate it, these are so complicated that most people attend the physical facilities in order to generate them.

Aguascalientes [www.aguascalientes.gob.mx](http://www.aguascalientes.gob.mx) has a *social networking* section but the label does not indicate its purpose. Citizens do not know if these are meant for citizens to share information in their own accounts, or to follow the government accounts. Oaxaca [www.oaxaca.gob.mx](http://www.oaxaca.gob.mx) solves this by adding the label "Follow us".

## III. Efficiency

It represents the speed at which a user manages to perform a task once he already knows the interface. [www.infonavit.org.mx](http://www.infonavit.org.mx) makes it very easy to find the information by using color coding (blue for workers, purple for employers and green for suppliers). Labels aid the navigation: "How much savings do I have?", "How can I get a credit", "How should I use my credit"...

On the other hand, [www.zacatecas.gob.mx](http://www.zacatecas.gob.mx) three days prior to the governor's annual report, redirected the website to another promoting this event. For three days people from Zacatecas could not use online services, pay taxes, or access information.

## IV. Memorability.

After visiting the site, will the user remember it enough to efficiently use the site during on future visits? Can the user recognize the features or will he need to learn again?

At [www.sat.gob.mx](http://www.sat.gob.mx) it is not clear where to find information of a requirement or how to pay my taxes for the first time. Terms like "SICOFI", "certisat" or "Solcedi" are only useful to those already familiar with this. The language used in the context help of Tax "Additional information" does not help to find information.

## V. Error frequency and their severity.

How often the users make mistakes, how severe are their mistakes and how to recover from them.

In the web portal Ensenada [www.ensenada.gob.mx](http://www.ensenada.gob.mx), the most popular services appear first. When a process is not available, it is clearly indicated with a yellow ribbon with the words "In Maintenance". In a very clear way, it prevents errors indicating that the service does not work temporarily.

## VI. Satisfaction

It indicates if the citizen likes to use the site. The level of satisfaction of a citizen who seeks services in Monclova's site [www.monclova.gob.mx](http://www.monclova.gob.mx) will be unsatisfactory. The two procedures that can be performed are the processing of birth certificate and consulting of CURP (identification register).

The great amount of services offered in Toluca's website [http://www.toluca.gob.mx/tramites\\_servicios?p=a](http://www.toluca.gob.mx/tramites_servicios?p=a) requires a search tool. This should be highly satisfying, but the search can be frustrating. When searching for "license", there are no results for driver's licenses. If "C" or "V" are used to search for "vehicle control" (as used in Nuevo León), the department is not found, because it is named differently. This can be very frustrating for migrating citizens.

### **Current rankings available in Mexico**

Although many international rankings are available, Waseda, Brown and ONU amongst them, in Mexico only one rank has been available until recently. The State eGovernment Index created by Sandoval, Luna and Gil, were the only reference by which websites were compared. This ranking is no longer being kept so the only tools by which websites were improved has disappeared.

Nonetheless, this index was focused mainly on technical aspects. For example, it evaluated whether there was a chat or not, on a true or false scale. But it didn't evaluate if the chat provided a reasonable service to citizens. It evaluated whether they had an events calendar, but not the quality of information provided in it. Thus, it could be plagued with proselytism events and not present any useful information to average people.

One of the crucial aspects to evaluate is the amount of screen space used for functionality versus the amount of information used to promote official activities and consequently the public servant himself.

### **Conclusion**

Most government websites in Mexico lack any common structure, catalogue of services, use of language or information requirements. State sites can be citizen oriented for a term, and an opposing party might completely change the sites objectives and become a platform for political propaganda on the next term. The motivation for websites to improve was a ranking recently abandoned.

Efficient planning and attention to detail will make a significant difference in the experience of the citizen. There is a great need for a new ranking of websites that focuses on the quality of services and interaction rather than just technical aspects.

### **References:**

- Aceves, L. & Martínez, A. (2008). *Mejores Prácticas en el Diseño de Portales Gubernamentales*. Monterrey, Mexico: UAWEB.
- Bowles, Cennydd & Box, James. (2011). *Undercover user experience: learn how to do great UX work with tiny budgets, no time, and limited support*. Berkeley, CA : New Riders
- Jacko, Julie A. (2012) *The human-computer interaction handbook : fundamentals, evolving technologies, and emerging applications*. Boca Raton, Florida: CRC Press
- Laynea, K., & Leeb, J. (2001). *Developing fully functional E-government: A four stage model*. Las Vegas, Nevada, USA.
- Lenguaje Ciudadano (2004) Secretaría de Gobernación. Sitio web: [http://www.gobernacion.gob.mx/work/models/SEGOB/Resource/148/1/images/Manual\\_lenguaje\\_ciudadano.pdf](http://www.gobernacion.gob.mx/work/models/SEGOB/Resource/148/1/images/Manual_lenguaje_ciudadano.pdf)
- Nielsen, Jakob. (2012). *Usability 101: Introduction to Usability*. June 13 2013, de Nielsen Norman Group. Sitio web: <http://www.nngroup.com/articles/usability-101-introduction-to-usability/>
- ONU. (2012). *Gobierno Electrónico, 2012*. UNPAN: [http://workspace.unpan.org/sites/Internet/Documents/EGovSurvey2012\\_Spanish.pdf](http://workspace.unpan.org/sites/Internet/Documents/EGovSurvey2012_Spanish.pdf)

- Sandoval Cervera, S. A. (2013). Gobierno Electrónico: Elementos de Facilidad de Uso y Valor Público de los Portales de Internet Local en México. FLACSO MÉXICO: [http://conocimientoabierto.flacso.edu.mx/medios/tesis/sandoval\\_sa.pdf](http://conocimientoabierto.flacso.edu.mx/medios/tesis/sandoval_sa.pdf)
- Sandoval, R. Gil, J. (2013). Construyendo un índice de funcionalidad para el gobierno electrónico: una primera evaluación de los portales estatales en México. Espacios Públicos UAEM: [http://www.plataformademocratica.org/Publicacoes/15096\\_Cached.pdf](http://www.plataformademocratica.org/Publicacoes/15096_Cached.pdf)
- The Waseda University Institute of e-Government. (2013). Waseda University International e-Government Ranking 2013. [http://www.e-gov.waseda.ac.jp/pdf/Press\\_Released\\_on\\_e-Gov\\_ranking\\_2013.pdf](http://www.e-gov.waseda.ac.jp/pdf/Press_Released_on_e-Gov_ranking_2013.pdf)
- West, D. (2008). Improving Technology Utilization in Electronic Government around the World. Governance at Brookings: [http://www.brookings.edu/~~/media/research/files/reports/2008/8/17%20egovernment%20west/0817\\_egovernment\\_west.pdf](http://www.brookings.edu/~~/media/research/files/reports/2008/8/17%20egovernment%20west/0817_egovernment_west.pdf)

# BUSINESS' PARTICIPANTS MOTIVATION IN OFFICIAL SURVEYS BY FUZZY LOGIC

*Miroslav Hudec, PhD*

Faculty of Economic Informatics, University of Economics in Bratislava, Slovakia

*Vanessa Torres van Grinsven, MSc*

Faculty of Social Sciences, Utrecht University, and Statistics Netherlands

---

## Abstract

Business statistics, collected and published by official institutes, are important for policy makers and for businesses in their management decisions. In spite of that, business participation in surveys is decreasing. This causes a decrease in quality of data and increases demands for data imputation procedures, endangering the value of survey based data collection. Improving the motivation of respondents could significantly influence the validity of business survey research. To achieve this, we suggest applying fuzzy logic to both dissemination tools for statistical data and adaptive survey design methods to tailor survey design to the characteristics of businesses.

Adaptive survey designs (ASDs) take into consideration the fact that the impact of various design features varies significantly over respondents. When auxiliary information is available from e.g. registry data, survey designs may be tailored to optimize response rates through strategies designed to enhance motivation. In a crisp classification design businesses or respondents although having similar attribute values, may be classified into different classes and therefore receive different treatments. Applying fuzzy logic to an ASD may lead to a more robust and effective classification when aiming at improving unit and item response and decreasing measurement error through the stimulation of motivation.

Statistical institutes provide data on their data portals. However, data users typically find it hard to distill the relevant data and information on these websites, which could demotivate them to cooperate in surveys. Therefore, in dissemination we should include methods capable of processing imprecise queries and methods for mining rules in the data.

---

**Keywords:** Data collection, data dissemination, motivation, fuzzy logic

## Introduction

Business statistics produced by National Statistical Institutes (NSIs) are very important for public policy making decisions but also for management decisions of businesses and other organizations. A significant part of the data necessary for these statistics is surveyed from business respondents. Participation of businesses in surveys, however, has been decreasing. This is a danger to survey-based data collection as it causes decreased quality of statistical data and increases demands for data imputation procedures. To ensure the quality of business survey research, improving the motivation of respondents to respond timely and accurately seems necessary (Torres van Grinsven et al., 2011, 2012).

The Generic Statistical Business Process Model (Vale, 2010) describes all required steps in data production in official statistics. Focusing on respondents' motivation, two parts are of main interest: data collection (survey design) and data dissemination. Respondents have to respond to many surveys but on the other hand often are not able to easily find relevant data on NSI websites. As a consequence "some businesses choose not to react to survey

requests (a problem of non-response) or invest insufficient effort (a problem of measurement error)” (Bavdaž et al, 2011, p. 7).

Tailoring business survey design could enhance response rates and survey quality as opposed to uniform design for all businesses (see e.g. Snijkers et al, 2013). In order to create a tailored survey design we should adopt an approach that is robust and ensures that similar respondents are always similarly treated. Businesses in a data user role cope with issues of how to find relevant data and information (Bavdaž et al, 2011). Therefore, they could prefer an intelligent data dissemination and mining tool capable of dealing with imprecise questions about the data and providing answers (data and mined information) in a useful and understandable way (Hudec, 2011; Kacprzyk and Zadrozny, 2009).

In both fields fuzzy logic (Zadeh, 1965) is a rational option that could provide the solution. The fuzzy logic works with overlapping sets, partial membership degrees and linguistic terms. It means that we could use fuzzy logic in classification of respondents and for example the creation of reminders for a tailored design; and on the other hand also for querying data on websites for dissemination (Hudec et al, 2012; Hudec, 2013a).

This paper discusses issues and perspectives of improving respondents’ motivation by fuzzy logic. The next section depicts the relation between respondents and the NSI. Following two sections are devoted to motivation in data collection and motivation of data users in the data dissemination part of statistical data production. Finally, concluding remarks are drawn in the last section.

## Respondents and NSIs

“We find that a paradox is steadily developing in a rapidly changing world, in that statistical users are becoming ever more demanding for timely data, but are less willing to provide their own data to statistical institutes” (Ross, 2009, p. 6). The paradox presumably appeared from the fact that respondents have to cooperate in many official surveys but they often are not able to easily find relevant data or mine relevant information from databases exposed on NSI data portals. Besides, businesses would like to avoid any activity which seems to be less relevant or do not bring expected benefit for them like sending the same or similar data to different recipients (Erikson et al, 2012). This is not surprising having in mind the pressures on productivity and rational use of resources. As a consequence businesses either choose not to react to survey requests or invest insufficient effort to fulfil questionnaires (Bavdaž et al. 2011). This is depicted in Figure 1.

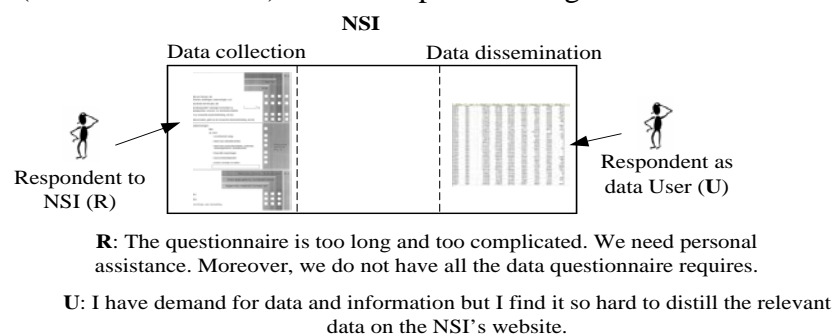

Figure 1: Statistical users

We would like to suggest ways for solving issues depicted in Figure 1. Analysing the consideration of respondent (R) we presume that the solution could be dividing respondents to groups and adapting surveys to each group. Adaptive survey designs (ASD) bring considerable advantage to the field of designing surveys by taking into consideration the fact that the impact of various design features varies significantly over respondents (Calinescu and Schouten, 2012). Adaptive survey designs (ASDs) have been introduced in Wagner (2008) and Schouten et al. (2011). ASDs have the potential to deliver a higher quality of survey

response than traditional survey designs that overlook this aspect (Calinescu and Schouten, 2012). In research on ASDs up to now sharp classification is used. In such a design thus respondents although having similar attribute values, may be classified into different classes and therefore receive different treatments.

Analysing the reasoning of data user (U) we could conclude that data dissemination by NSI data portals is a significant element for motivation to work with statistical data either in a positive or negative way (Hudec et al. 2012). If a data portal is well designed and users can easily find relevant data and information, they will be more motivated to provide their own data. Users want either raw data (large businesses) or extracted rules from data and information (small businesses) (Bavdaž et al., 2011). It is assumed that if we provide businesses not only with data but also information with meaning using appropriate data mining tools inspired by a human way of reasoning, they will be more satisfied and willing to provide their own data.

Linguistic terms used in fuzzy logic computations describe respondents and at the same time include a certain vagueness or uncertainty that crisp (sharp) procedures based on two-valued logic {true, false} do not understand and therefore cannot use (Galindo et al, 2006). In the crisp classification, an entity is selected or not, a rule is valid or not and objects belong only to one class. This might cause that respondents which contain similar values of analysed attributes are improperly ranked or classified. Certain respondents will fall out of the class where they should be. For example, we might set a certain date as the limit to respond in time. Every respondent that responded before that date will be classified to respond in time; yet respondents that respond just the day before that date, might have more similarities with a respondent that responds the day after than with a respondent that was also in time but responded two weeks before the deadline. Therefore, we could have a wrong impression of the attitude of the respondents (Křůčik et al, 2012).

Fuzzy set theory provides a framework for systematically handling the described vagueness (fuzziness). The vagueness and uncertainty discussed in this paper is not based on randomness; it cannot be presented as a crisp (sharp) value (Zimmermann, 2001). Main advantages to use fuzzy logic are discussed in Dubois and Prade (1997) and advocated in Kacprzyk and Zadrozny (2001). Abdullah et al (2004) emphasized that even though the fuzziness is closely related to phenomena in social sciences, the mathematics of fuzzy logic is mainly applied in engineering and computer science. This trend continues allowing engineering systems to be more and more sophisticated and powerful. We could reach the same level in social sciences if we support some tasks by fuzzy logic.

### **Motivation in data collection**

Data collected by NSIs is important for policy decisions. In order to achieve their institutional tasks, NSIs traditionally perform surveys. The quality of resulting data strongly depends on businesses' cooperation. As Erikson et al. (2012) pointed out, people do not consider surveys as important to society as before and therefore neither so important to participate in. The refusal rates and non-contact rates are rising all over the world. Business respondents often complain about response burden. Besides, they often reject participation in surveys (Giesen, 2011), or pay less attention to the survey task with the consequence of poor quality data (Bavdaž, 2010).

### **Current state**

In survey-based research, the problem is most visible in declining response rates (de Leeuw and de Heer, 2002; Baruch, 1999) that have stabilized at a low level in organization research (Baruch and Holtom, 2008). Businesses increasingly complain about the response burden and often refuse to participate in both voluntary and mandatory surveys (Giesen, 2011). This is not surprising given the huge pressures on productivity and rational use of

resources. Even when they do participate, their attention to the survey task might not be sufficient, which leads to a more covert problem of poor quality of reported data. This increasing reluctance to cooperate endangers survey-based research and raises questions concerning the validity of the results of this line of surveys. When businesses refuse to cooperate, this may result not only in unit non-response (business refuse to reply on survey request), but also in item non-response (respondents do not fill all required fields in forms) and inaccuracy (measurement error - the observational gap between the ideal measurement and the response obtained (Groves et al. 2004)). Experience and research have shown that measurement errors in business surveys may be far from negligible (Bavdaž, 2010).

The extent of this survey error might be most easily evaluated in governmental surveys where recent studies suggest that as much as 30 % (e.g. Adolfsson et al, 2010) of the total survey cost is spent on data editing (imputation). The root cause of this problem seems to lie in its character of being an 'irritation burden' (European Commission High Level Group of Independent Stakeholders on Administrative Burdens, 2009), and not in the actual survey burden imposed on businesses that represents only around 0.5 % of the total administrative burden. Recent research suggests that problem of declining response rates and poor data quality indicates that the drive behind behavior – the motivation for the business survey task – is insufficient or lacking (Torres van Grinsven et al, 2012).

Current motivational practices, like reminders and (threats of) fines in the case of non-response, seem to achieve their aim of assuring business survey response (Torres van Grinsven et al, 2012). But there are much more possible ways to enhance motivation of businesses that can be tailored for an adaptive survey design according to a business' characteristic and which, applied the correct way, might result to be much more effective to promote response rates, item response, timeliness and accuracy.

Torres van Grinsven et al (2011, 2012) have identified sources of motivation that are of importance for the business survey task, which are facets of the broader communication aspects of the survey design. Besides, they suggest that, indeed, motivation is an important factor influencing the survey outcome, and propose which types of motivation should be important for the business survey task (Torres van Grinsven et al, in review process). They suggest that survey outcome reflects the amount of motivation to perform a task through direction, intensity and persistency of the behavior; the higher the motivation: (a) the more favorable initial choices related to the task, (b) the higher amount of effort invested in the task, and (c) the more persistence at the task in the presence of obstacles; and that it depends on these three dimensions whether or not the survey outcome is the desired one: survey response providing timely and accurate data, though the importance of other factors, such as capacity and authority is acknowledged.

**Example:** As an illustrative example we have created output variable: respondents' attitude to NSI. For this purpose we have created the following output classes: small, medium, medium high and high. Input consists of one qualitative indicator: Official statistics is frequently used in our business (Q1) and one quantitative indicator: trade value. It is not the same if businesses with small trade value and businesses with high trade do not respond timely and accurately or have a negative image of the NSI. Let's describe the problem in the following way:

*if trade value is small and Q1 is small, our interest in business respondent is small;*

*if trade value is small and Q1 high, our interest in business respondent is medium;*

*if trade value is high and Q1 is small, our interest in business respondent is medium high;*

*if trade value is high and Q1 high our interest in business respondent is high.*

Indicator trade value is fuzzified into two fuzzy sets using the uniform domain covering method (Tudorie, 2008) adapted to the case of two fuzzy sets. Indicator Q1 is fuzzified by directly assigning membership degree to all five values.

The obtained solution for selected businesses (extracted from Klůčik et al, 2012) is presented in Table 1. For example respondent 8 is very close to fully meet the condition high relevance for the NSI. This means that some tailored motivation strategy could result in the change of their opinion of using statistical data from value of 4 to value of 5.

**Table 1:** Some of classified businesses – quantitative and qualitative data

Respondent	Q1	Trade value	$\mu(S)$	$\mu(M)$	$\mu(MH)$	$\mu(H)$	Relevance
1	5	60301	0	0	0	1	0,9
2	5	87555	0	0	0	1	0,9
3	5	58912	0	0	0,0347	0,9653	0,891325
4	5	56777	0	0	0,1422	0,8578	0,86445
5	5	53870	0	0	0,2885	0,7115	0,827875
6	5	52097	0	0	0,3778	0,6222	0,80555
7	5	50314	0	0	0,4675	0,5325	0,783125
8	4	66298	0	0,25	0	0,75	0,7625
9	4	60734	0	0,25	0	0,75	0,7625
10	5	45838	0	0	0,6928	0,3072	0,7268
11	5	42216	0	0	0,8751	0,1249	0,681225
12	5	6927	0	0	1	0	0,65
13	5	19747	0	0	1	0	0,65
14	5	34978	0	0	1	0	0,65
15	3	91027	0	0,5	0	0,5	0,625
...							

For example if we want to motivate businesses to actively use statistical data we can offer them some percentage of discounts (if NSIs charge preparing and providing data) according to their importance for NSI (trade value) and their significance as customers. Let respondents belonging to class high receive 9% discount of price for provided data and respondents belonging to class medium high 6.5% discount. In a crisp classification respondent 4 will receive a discount of 6.5% (or 9% depending of classes definitions) although it is closer to the class high than medium high. In our approach we can offer a discount of 8.6% (if the definition of crisp class forced this business to class high then the business is not motivated to improve its relation with NSIs).

Entities with similar values of examined attributes are similarly classified and treated using only four fuzzy rules which are easily readable and modifiable by decision makers in motivation. However, we can use crisp classification but in that case we should create larger number of classes. Therefore, model will not be as easily maintainable and understandable for decision makers in motivation as it is in the case of flexible classification.

### **Perspectives (Further research and development)**

Respondents show a certain response style that may lead to different levels of response errors. On the other hand, this means that ways to enhance respondents' motivation might vary in effectiveness according to different types of respondents. Therefore, a tailored design has the potential to deliver a higher quality of survey response than traditional survey designs that overlook this aspect (Calinescu and Schouten, 2012). In most surveys all sample units receive the same treatment and the same design features apply to all selected people and households. When auxiliary information is available from e.g. registry data, like type of industry or size of the business, survey designs may be tailored to optimize response rates through strategies designed to enhance motivation. In these so called adaptive survey designs thus different people, households or businesses may receive different treatments. Wagner (2008) introduced the term adaptive design, describing the differential survey designs tailored to the characteristics of sample units, using rules specified before data collection. Recently, a tailored adaptive design was compared with a standard uniform survey design in an



experimental setting by Statistics Netherlands for a household survey (Luiten and Schouten, 2013). This tailored design was directed towards the improvement of the representativeness. The results showed that the tailored fieldwork strategy was successful in maintaining the level of response, while significantly augmenting representativeness

We propose such a differential fieldwork strategy, trying to maintain survey response at a level necessary for precise survey estimates (Schouten, 2010), yet aimed at maximizing motivation and using fuzzy logic for classification and ranking. The intention of maximizing motivation is increasing the overall quality of the survey response. Representativeness, as measured in Luiten and Schouten's (2013) experiment is one possible way of measuring this quality.

Applying fuzzy logic to a classification and ranking to support an adaptive survey design, might lead to more robust and effective design when aiming at improving unit and item response and decreasing measurement error. Fuzzy logic allows us to examine "levels of grey" like the degree of matching of a selection condition, the extent to which a rule is satisfied, and the inclusion of objects to several overlapping classes with different matching degrees. In addition, including logical structures into an aggregation function significantly improves respondents' evaluation, ranking and classification. Fuzzy logic approach is able to classify respondents using several kinds of valuable data at the same time (quantitative, categorical and even textual). It ensures that respondents with similar values are always similarly treated. Concerning realization, respondents belong to groups for an adaptive design with certain intensity. This intensity could be used to ensure that similar respondents are similarly treated.

Motivation by fuzzy logic was examined in the customer relationship management (Meier et al, 2005; Werro et al, 2005) to motivate customers by robust and easy to use fuzzy classification. However, up to now no research was focused on respondent motivation by fuzzy logic in official statistics data collection. Our goal is among others to integrate ideas and results from static flexible classification (Werro et al, 2005), dynamic flexible data classification by fuzzy queries (Hudec and Vujošević, 2012) and improve fuzzy logic approach by real sets (Radojević, 2008), and to apply them on adaptive survey designs. All these approaches could bring robust, easy to use, and logically consistent approach for solving issue recognized in ASDs.

### **Motivation in data dissemination**

Statistical institutes have created large amounts of data that contain knowledge potentially valuable for businesses. However, business data users are not always interested in sheets of figures, but they also search for information like relational knowledge in the data that is usually shaded by large amounts of data sets. Data with meaning could be more useful than pure data.

### **Current state**

In this field several approaches have been suggested for improving dissemination in different ways such as WEB 2.0 (Smith, 2011) or presenting selected indicators in tables and maps (Jern et al., 2011). The eye tracking method (Wulff, 2007) can evaluate users' habits and reveal if it is difficult for users to navigate to relevant information and how to improve the design of portals. Although all these approaches significantly improve data dissemination capabilities of NSIs, data dissemination in a way which mimics human approximate reasoning (without precise measurement but very powerful tool) is still missing.

As was mentioned above data users (businesses) search for (raw) data or extract rules (relations, dependencies, summaries) from data. For example, business wants to obtain available data for municipalities that have *small pollution, medium altitude and high unemployment*. The suitable answer is list of municipalities ranked downward according to

the degree of satisfying this condition. As an example for extracting rules, let's have business that wants to know to which degree rule *most of municipalities with high altitude above sea level have low gas consumption* is satisfied. Rule checks assumption that these municipalities mainly use other sources for heating. Moreover, the meaning of query or rule for mining information is expressed by linguistic terms, in a way understandable at the first glance.

Imprecise queries for data and information cannot be straightforwardly converted into numeric constraints. Therefore we should create bridge between users and databases. Concerning the first user demand, fuzzy queries (based on fuzzy logic) is option which offers the solution (Hudec, 2013a). Regarding the second user demand, recent development in linguistic summaries which are based on fuzzy logic is promising (e.g. Hudec, 2013b; Kacprzyk and Zadrozny, 2009).

**Example:** User wants to know whether each region is more hilly or flat. This question is expressed by the linguistic *summary most of municipalities have small attitude above sea level*. The result for all eight regions of the Slovak Republic is presented in Table 2 ranked downwards starting with region having the highest value of the rule validity (flatness of region). We see for example that region Trenčín is more flat than hilly. The same holds for region Košice but it is a slightly hillier than region Trenčín. The first advantage in this case is keeping data that are not free of charge or sensitive hidden from users. In the example only mined information for each region calculated from municipal data is presented. No data of municipalities (used in calculation of rule's validity) is revealed to user.

**Table 2:** Validity of the rule expressed by linguistic summary for each region

Region	Validity of the linguistic summary
Bratislava	1
Trnava	1
Nitra	1
<i>Trenčín</i>	<i>0.7719</i>
<i>Košice</i>	<i>0.6314</i>
<i>Bánska Bystrica</i>	<i>0.2116</i>
<u>Žilina</u>	<u>0</u>
<u>Prešov</u>	<u>0</u>

Further, a linguistic summary could expose a ranking of areas with most large businesses in a certain industry or countries of most frequent exports. The rule is: *export by countries has high number of reports*. Table 3 shows most frequent export countries obtained from the Slovak Intra-EU trade database (Křůčik et al, 2012). When policy makers, businesses, etc. are not interested in data but in aggregated information, then linguistic summaries are the solution.

**Table 3:** Countries with high number of reports

Country	High number of reported trade
AT	1
CZ	1
DE	1
HU	1
PL	1
<i>FR</i>	<i>0,9533</i>
<i>IT</i>	<i>0,777</i>
<i>RO</i>	<i>0,3277</i>
<i>SI</i>	<i>0,1222</i>
<i>NL</i>	<i>0,0449</i>
<i>GB</i>	<i>0,0394</i>
<i>BE</i>	<i>0,0137</i>

### **Perspectives (Further research and development)**

Mathematically, relevant equations which support flexible data queries and rule extraction are created and explained in many papers e.g. (Hudec 2009; Kacprzyk and Zadrozny, 2009; Werro et al, 20005). Nevertheless, research in fuzzy logic continues to examine further issues in theory and limitations for application e.g. (Radojević, 2008; Radojević, 2013). The next step is creation of full web applications. It is task for experts in fuzzy logic; design of web application and in motivation. Although fuzzy logic has proved its advantages, surveys among key data users among businesses about their needs and tailored advertisement of new approach is required.

It is obvious that processing flexible queries introduces additional computation burden due to the additional amount of calculations concerning data and information retrieval (Kacprzyk et al, 2000). On the other hand, this additional amount of calculations is balanced with additional valuable information mined from a database in a way that is more suitable for data users.

Having in mind computational burden and respondents' motivation, one possible solution is restricted access to flexible data dissemination according to the level of the users' cooperation as respondents. Full access could be offered only for respondents which fully cooperate in surveys. Partial access could be offered to respondents which have small delay or several non-responded data. No access for respondents which are far to meet requirements of NSIs. Anyway, demo version should be offered for all respondents. It will be interesting to calculate the influence of flexible and human oriented data dissemination to respondents' willingness to cooperate in mandatory and voluntary surveys.

### **Conclusion**

Business respondents play the pivotal role in data collection and are key users of aggregated statistical data in data dissemination. Therefore, efforts in improving respondents' motivation by fuzzy logic could convey benefits for both sides. Respondents will work in a more human oriented way, tailored to their characteristics and wishes, in searching for relevant data and rules, and in filling questionnaires and therefore, will be more motivated to cooperate in surveys. For NSIs it means collection of data of better quality reducing the computation burden focused on managing reminders and data imputation. This is especially important in continuously tightening of budgetary constraints. Merging social sciences with fuzzy logic and information science could considerably improve the quality of statistical data.

In dissemination the solution capable of giving answers to imprecise queries and questions related to statistical data is a way for increasing motivation to explore data produced by NSIs. In flexible queries selected entities are ranked downwards from the best to the worst. Linguistic summaries answer questions related to data and keep data that are not free of charges or sensitive hidden. Fuzzy logic can solve more user demands and therefore improve the image of NSIs as data providers.

In data collection, fuzzy logic can help identifying key respondents using several criteria at the same time (quantitative, textual, and categorical) and ensure that similar respondents are always similarly treated in a tailored or adaptive survey design. Flexible sets with overlapping boundaries are a framework for preparing adaptive survey designs and therefore create motivation tailored to each group of respondents.

### **References:**

Abdullah Mohd. Lazim, Wan Salihin Wong Abdullah, and Abu Osman Tap. Fuzzy Sets in the Social Sciences: An Overview of Related Researches. *Jurnal Teknologi*, 41(E): 43–54, 2004.  
Adolfsson, Chandra, Gunnar Arvidson, Peter Gidlund, Andres Norberg, and Lennart Nordberg. May 5). Development and Implementation of Selective Data Editing at Statistics Sweden. European Conference on Quality in Official Statistics, Helsinki, Finland. Retrieved

from

[http://q2010.stat.fi/media//presentations/Norberg\\_et\\_all\\_\\_Statistics\\_Sweden\\_slutversion.pdf](http://q2010.stat.fi/media//presentations/Norberg_et_all__Statistics_Sweden_slutversion.pdf), 2010.

Bavdaž, Mojca (2010). Sources of Measurement Errors in Business Surveys. *Journal of Official Statistics*. 26(1): 25-42, 2010.

Bavdaž, Mojca, Silvia Biffignandi, Irena Bolko, Deirdre Giesen, Dag Gravem, Gustav Haraldsen, Tora Löfgren, Boris Lorenc, AndreasPersson, Petra Mohoric Peternelj, Rudi Seljak, and Vanessa Torres van Grinsven. Final report integrating findings on business perspectives related to NSIs' statistics. Deliverable 3.2., Blue-Ets Project, <http://www.blue-ets.istat.it/fileadmin/deliverables/Deliverable3.2.pdf>, 2011

Baruch, Yehuda. Response Rate in Academic Studies — A Comparative Analysis. *Human Relations*, 52(4): 421–438, 1999.

Baruch, Yehuda, and Brooks Holtom, Survey Response Rate Levels and Trends in Organizational Research. *Human Relations*, 61(8): 1139–1160, 2008.

Calinescu, Melania, and Barry Schouten. Adaptive survey designs that minimize nonresponse and measurement risk. The Hague/Heerlen: Statistics Netherlands, 2012.

De Leeuw, Edith and Wim De Heer, Trends in household survey nonresponse: A longitudinal and international comparison. In R.M. Groves, D.A. Dillman, J.L. Eltinge, and R.J.A. Little (eds.), *Survey Nonresponse* (pp. 41–54). New York: Wiley, 2002.

Dubois, Didier, Henri Prade. Using fuzzy sets in flexible querying: Why and how? In: Andreasen, T., Christiansen, H., Larsen H.L. (eds.), *Flexible Query Answering Systems* (pp. 45-60), Dordrecht: Kluwer Academic Publishers, 1997.

Erikson, Johan, Gustav Haraldsen, and Ger Snijkers. The future of statistical data collection? Challenges and opportunities. Seminar on New Frontiers for Statistical Data Collection, Geneva, Retrieved from: <http://www.unece.org/stats/documents/2012.10.coll.html> , 2012.

Galindo Jose, Angelica Urrutia, and Mario Piattini. *Fuzzy databases: Modeling, Design and Implementation*. Hershey: Idea Group Publishing Inc, 2006.

Giesen, Deirdre ed. Response Burden in Official Business Surveys: Measurement and Reduction Practices of National Statistical Institutes. BLUE-ETS Project Report. Retrieved from <http://www.blue-ets.istat.it/fileadmin/deliverables/Deliverable2.2.pdf>, 2011.

Groves, Robert, Floyd Fowler, Jr., Mick Couper., James Lepkowski, Eleanor Singer., and Roger Tourangeau. *Survey Methodology*. Hoboken, NJ: Wiley-Interscience, 2004.

Hudec, Miroslav. Improvement of data collection and dissemination by fuzzy logic. UNECE/Eurostat/OECD Meeting on the Management of Statistical Information Systems (MSIS), 2013a.

Hudec, Miroslav. Applicability of linguistic summaries. XI Balcan conference on operational research, Belgrade, 2013b.

Hudec, Miroslav .Fuzzy database queries in official statistics: Perspective of using linguistic terms in query conditions. *Statistical Journal of the IAOS* (in press).

Hudec, Miroslav, Simona Balbi, Jana Juriová, Miroslav Klůčik, Marina Marino, Germana Scepi, Maria Spano, Agnieszka Stawinoga, Cristina Tortora. Nicole Triunfo. Report on principles of fuzzy methodology and tools developed for use in data collection (Soft computing and text mining tools for Official Statistics). Deliverable 5.1, Blue-Ets Project, <http://www.blue-ets.istat.it/fileadmin/deliverables/Deliverable5.1.pdf>, 2012.

Hudec, Miroslav. Exploration of applying fuzzy logic for official statistics. Proceedings of the New Techniques and Technologies for Statistic, European Commission, Brussels, 2011.

Hudec, Miroslav. An approach to fuzzy database querying, analysis and realisation. *Computer Science and Information Systems*, 6(2):127-140, 2009.

Hudec, Miroslav, and Mirko Vujošević. Integration of data selection and classification by fuzzy logic. *Expert Systems with Applications*, 39:8817–8823, 2012.

- Jern, Mikael, Marie Haldorson, and Lars Thygesen. *Storytelling – how to visualize statistics*. Conference on New Techniques and Technologies for Statistics, Brussels. <http://www.ntts2011.eu/>, 2011.
- Kacprzyk, Janusz, and Slawomir Zadrozny. Protoforms of Linguistic Database Summaries as a Human Consistent Tool for Using Natural Language in Data Mining. *International Journal of Software Science and Computational Intelligence*, 1: 1-11, 2009.
- Kacprzyk, Janusz, and Slawomir Zadrozny. Computing with words in intelligent database querying: standalone and internet-based applications. *Information Sciences*, 134:71–109, 2001.
- Kacprzyk, Janusz, Gabriella Pasi, Peter Vojtáš P., and Slawomir Zadrozny. Fuzzy querying: Issues and perspectives. *Kybernetika*, 36(6): 605-616, 2000.
- Klůčik, Miroslav, Miroslav Hudec, and Jana Juriová. Final report on the case study results on usage of IT tools and procedures developed for data collection (Soft computing tools for Official Statistics). Deliverable 5.2, Blue-Ets Project, <http://www.blue-ets.istat.it/fileadmin/deliverables/Deliverable5.2.pdf>, 2012.
- Luiten, Annemieke and Barry Schouten. Tailored fieldwork design to increase representative household survey response. An experiment in the Survey of Consumer Satisfaction. *Journal of the Royal Statistical Society, series A*, 176: 169-191, 2013.
- Meier, Andreas, Nicolas Werro, Martin Albrecht, and Miltiadis Sarakinos. Using a Fuzzy Classification Query Language for Customer Relationship Management. *Conference on Very Large Data Bases*, 2005.
- Radojević, Dragan. Truth Functionality Is Consequence of Structural Functionality and Valid Only in Classical Two-Valued Case. XI Balcan conference on operational research, Belgrade, 2013.
- Radojević, Dragan. Interpolative realization of Boolean algebra as a consistent frame for gradation and/or fuzziness. In: Nikraves, M., Kacprzyk, J., Zadeh, L.A. (eds.): *Forging New Frontiers: Fuzzy Pioneers II Studies in Fuzziness and Soft Computing*. Springer-Verlag: Berlin and Heidelberg, 295-318. 2008
- Ross, Michael Pace. Official Statistics in Malta – implications of Membership of the European Statistical System for a small country/NSI. 95th DGINS Conference "Migration - Statistical Mainstreaming", 2009.
- Schouten, B. (2010) Dynamic Adaptive Survey Designs; From Paradata to Data. Paper presented at the 21st Workshop on Household Survey Non-response. Nürnberg, GE, August 30 – September 1.
- Schouten, Barry, Melania Calinescu, and Annemieke Luiten. Optimizing quality of response through adaptive survey designs. Discussion paper 201118, The Hague/Heerlen: Statistics Netherlands, 2011.
- Snijders, Ger, Gustav Haraldsen, Jacqui Jones, and Diane Willimack. *Designing and Conducting Business Surveys*. Hoboken: Wiley, 2013.
- Torres van Grinsven, Vanessa, Irena Bolko, Mojca Bavdaž, and Silvia Biffignandi. Motivation in Business Surveys. Proceedings of the BLUE-ETS Conference on Burden and Motivation in Official Business Surveys, Statistics Netherlands, <http://www.cbs.nl/NR/rdonlyres/23FD3DF5-6696-4A04-B8EF-1FAACEAD995C/0/2011proceedingsblueets.pdf>, 2011.
- Torres van Grinsven, Vanessa, Irena Bolko, and Mojca Bavdaž. Sources of Motivation in Business Surveys. Fourth International Conference on Establishment Surveys (ICES IV), June 11 – 14, Montréal, Québec, Canada, <http://www.amstat.org/meetings/ices/2012/papers/302172.pdf>, 2012.
- Torres van Grinsven, Vanessa, Irena Bolko, and Mojca Bavdaž, (in review process). The role of motivation in survey outcome: a conceptual model.

- Tudorie, Cornelia. Qualifying objects in classical relational database querying. Galindo J. (Ed.), *Handbook of Research on Fuzzy Information Processing in Databases*. IGI Global: London, 218-245, 2008.
- Vale, Steven. Exploring the relationship between DDI, SDMX and the Generic Statistical Business Process Model. *Proceedings of the 2nd Annual European DDI Users Group Meeting*, 2010.
- Wagner, James. Adaptive survey design to reduce nonresponse bias. PhD thesis, University of Michigan, 2008.
- Werro, Nicolas, Andreas Meier, Christian Mezger, and Gunter Schindler. *Concept and Implementation of a Fuzzy Classification Query Language*. International Conference on Data Mining. CSREA Press, 2005.
- Wulff, Annegrete. Experiences using the eye-tracking method to test website usability. *UNECE/Eurostat/OECD Meeting on the Management of Statistical Information Systems (MSIS 2007, Geneva, 2007)*.
- Zadeh, Lotfy. Fuzzy sets. *Information and Control*, 8:338-353, 1965.
- Zadrożny, Sławomir, and Janusz Kacprzyk. Issues in the practical use of the OWA operators in fuzzy querying. *Journal of Intelligent Information Systems*, 33: 307-325, 2009.
- Zimmermann, Hans-Jurgen. *Fuzzy Set Theory – and Its Applications*. Kluwer Academic Publishers: London, 2001.

# EXPERIMENTAL HYBRID SOLAR CONCENTRATOR UNIT SYSTEM FOR SANITARY WATER

*Vitali, A.*

*Modai, E.*

*Jiménez Placer, G.*

*Moron, I.*

*Zambrano, Daniel*

IDEI, UNGS, J.M. Gutierrez, Argentina

---

## Abstract

The availability of solar energy and its use for heating sanitary water is a resource that has been used since ancient times. However, current technologies allow optimization and its widespread use. In the project carried out by the National University of General Sarmiento (UNGS), it has designed an experimental system hybrid solar concentrator unit for heating water for sanitary use. This project was intended as a complement to traditional water heating for domestic use, based on a parabolic concentrator.

The system was designed so that it can be used in existing conventional facilities or be installed as the primary system for heating water. All components are within the structure of the base parabolic concentrator, which allows transport and fixation.

The proposed project conserves the energy consumption of a traditional water heater, develop applications and combine existing technologies in a solar tracking parabolic concentrator, so to optimize its operation. Not used the traditional flat panel, but experimented with a heat exchanger mounted in the focal zone of the concentrator.

One of the main objectives of this project was to arrive at a design of an integrated product that contains all the necessary elements for operation in a single platform. This adjusted the designs and location of components achieving optimal layout of the facility, giving greater freedom in the design development and implementation of design concepts.

This system will allow conventional energy saving which is normally used for purposes of domestic water heating, but plans to integrate these conventional systems. That is why we speak of a hybrid system, which uses solar energy and conventional energy (electricity or gas).

Considering the average consumption that occur in a house with four people, this system can replace between 45% and 91% of the energy used for water heating use, depending on time of year and considering its application in the Argentina northwestern area. The components were sized according to the proposed operating conditions.

In the case of solar energy utilization, the analysis was extended to different geographic locations of the country, analyzing performance and selecting different areas favorable for the implementation of the system.

This project will lay the foundation for the future development of associated projects conducted by researchers and students of the university, such as the study of the control loops, the solar tracker system development and the possible construction of a prototype, for academic use.

---

**Keywords:** Thermo tank, solar concentrator, heat exchanger, accumulator

## 1. Introduction

Mass consumption of hydrocarbons is producing changes in global atmosphere. The levels of carbon dioxide (CO<sub>2</sub>) which are currently detected are significantly higher than those existing in 1950. This, together with the accumulation of other gases produces the well-known greenhouse effect, which partially causes the increase in global average temperatures. Another known effect from the use of fossil fuels, is the effect known as acid rain, which causes great damage to the environment and human health. Thus both economic and ecological reasons, it is imperative to develop new energy alternatives that are less aggressive to the environment. In this regard, a large percentage of power is commonly used for heating water for domestic use. Hot water is significant energy consumption at homes, having various uses such as personal hygiene and cleanliness. Worldwide has become the second most important domestic energy use after heating and cooling. For this reason, the water heating by solar energy, beyond being an environmentally friendly alternative, it has become an economically attractive and competitive technology in many countries. In recent years there has been a significant increase in solar thermal installations in the world, technological advances allowed the manufacture of better quality systems at lower cost and society understands the need to replace fossil fuels. The use of complementary systems for the partial replacement of conventional energy sources is a valid way to improve the quality of life. This project explores the possibility of replacing some conventional energy used to heat water for sanitary use in private homes, by an alternative source that uses renewable energy. Given these guidelines an autonomous system has been designed, that will complement and replace the energy that today is used for this purpose. We will start from developments already made in the University [3] and similar works [1].

## 2. Solar energy and its use.

The use of the energy provided by the sun is dependent on the intensity of solar radiation received at ground level, daily and annual cycles, and weather conditions of the place.

We define solar energy as one by conversion to heat or electricity takes advantage of the radiation from the sun. From the energy point of view, the solar mass per second is radiated into space in the form of high-energy particles and electromagnetic radiation is approximately  $5.6 \times 10^{35}$  GeV, and from that radiation the earth receives in its outside atmosphere a total of  $1,73 \times 10^{14}$  kW, or  $1,353 \text{ kW/m}^2$ , which is known as the solar constant whose value fluctuates  $\pm 3\%$  due to the periodic variation of the distance between Earth and Sun [4]. The atmosphere and land surface are at different average temperatures and therefore also radiate energy. Thus the wavelength of the solar radiation lies between 0.05 microns and 4 microns, and it means, it is long-wave emission.

From an analysis of this radiation, it follows that only 47% of the incident solar energy reaching Earth's surface, 31% do so directly and another 16% after being scattered by dust, water vapor and air molecules, the rest of the solar energy, 53%, does not reach the surface of the Earth. The 15% is absorbed by the troposphere (water, ozone and clouds), 23% is reflected by clouds, 7% is reflected from the floor, 2% is absorbed by the stratosphere, mainly by ozone and 6% is the energy released by the atmosphere [4].

Radiation is usable in direct and diffuse components. Direct radiation is the one that comes directly from the sun focus, without intermediate reflections or refractions. The diffuse is issued by the daytime sky due to multiple reflection and refraction phenomena in the solar atmosphere, clouds and other atmospheric and terrestrial elements. Direct radiation can be reflected and concentrated for use while it is not possible to concentrate the diffused light coming from all directions.

As we mentioned above, the radiation varies by time of day, atmosphere conditions that absorbs it, and latitude. It can be assumed that in good irradiation conditions the value is



about  $1000 \text{ W} / \text{m}^2$  at the earth's surface . This power is known as irradiance . Another term to remember is called heliophany, representing the duration of sunshine or daylight hours.

### 3. Development

In order to contribute positively to the decline in consumption of traditional energy sources , we propose to replace gas or electricity as heat source, normally used to heat water for domestic use , by a system to supplement or replace these energy sources , using a solar heating system .

On this purpose various configurations of systems were analyzed, that allow the use of these alternative sources , for then propose a system that meets technical and economic objectives .

Thus, after analyzing existing possibilities, it was decided to develop a typology that combines various technical solutions . To this aim we have proposed , to design and dimension an energy recovery system that can work independently and as a single building block , using solar thermal power and also can complement and integrate the traditional system for sanitary water heating ( SWS ) . This system can function not only as a replacement of the traditional system , but as an electricity or GAS economizer consumed by an ordinary water heater , thus achieving a "hybrid " system.

The use of solar panels dates back to 120 years , and during this period there were several different forms of solar thermal collectors ranging from flat to parabolic collectors and heliostats . It is estimated at worldwide installed area of  $58 \times 10^6 \text{ m}^2$

For our project collectors were used , but with a particular geometry , by combining different effects. This development can contribute to the use of an untapped resource in our country. In Argentina the use of solar collectors [5 ] for this purpose is very low in contrast to other countries such as Europe and China. In central and northern Argentina the weather is relatively good, but in the winter months and a few days of fall and spring it is necessary to provide heat providing order to have minimum comfort conditions in homes.

According to the analysis , taking into account climatic variations that can cause sequences of several cloudy days and / or cold , it becomes clear that it is not possible to cover 100% of the energy needed to heat water using solar energy only, and therefore required to provide a percentage of the claim with another type of energy.

This, together with the difficulties to provide heat energy in regions far from major population centers, where there is no natural gas network or the availability of electric power, justifies the implementation of a hybrid system that is developed in this paper .

#### 3.1 Conventional solar collector

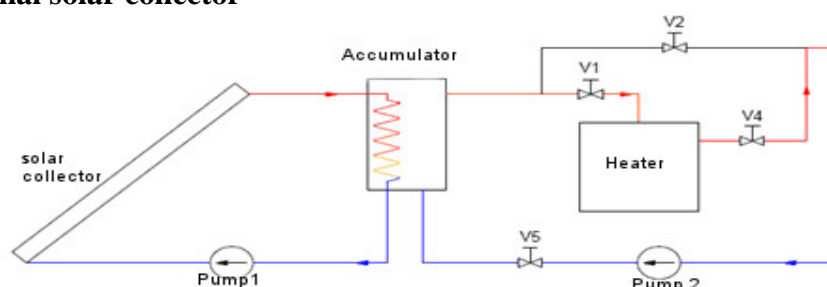

Figure 1. "Conventional" System with interchanger-Accumulator

In existing systems for heating water by solar energy we can analyze conventional collector systems [6]. In this system (Figure 1), a conventional solar collector integrated is used in the existing heating system incorporating an intermediate heat exchanger. This configuration allows the use of solar panel systems in closed water circuit and uses a heat exchanger to transfer heat energy to the water that will be used for sanitary purposes. It also

allows connection to existing heating system, either a simple water heater or boiler. Generally these systems have a circulation pump.

In this application (Figure 1), water is preheated from a boiler using an accumulator that functions as a heat exchanger. Pump 1 recirculates fluid that transports energy received from the sun. This fluid through the heater which is located in the solar concentrator receives energy from the sun by conduction and convection. The heat once transferred to the accumulator warms the clean drinking water that enters through the valve V5 by Pump 2 and enters the boiler through the valve V1 preheated. This fluid, that arrives reaching a certain temperature  $T_e$ , makes boiler system working in a regime lower than normal decreasing gas consumption from 10% to 15%.

In conventional solar heaters, because they are fixed related to the earth, it can be shown that absorber plates efficiency decreases for not having a mechanism to accompany the sun path during the day and thus receive sunlight directly (direct radiation). The direct impact also varies by time of year. Then Figure 2 shows the change in trajectory of a fixed point on the Earth's crust in different months of the year.

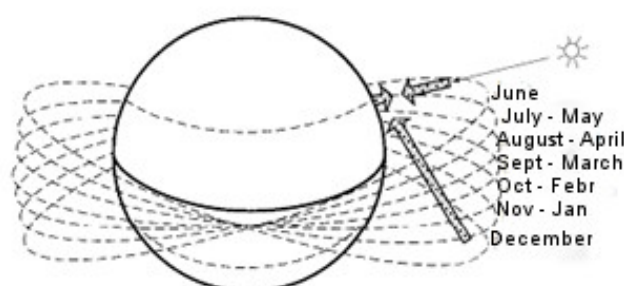

Figure 2. Trajectories of a fixed point on the Earth's crust in different months of the year

Because of these variations, and considering that the power available varies with the angle of incidence, it is observed that the system could be improved by developing a solar collector that has a tracking system accompanying the sun path during the day and thus captures more efficiently direct radiation. This device may increase system performance over conventional solar panels between 30% and 40%. To resolve issues of installation autonomy and heat loss reduction, it will be designed a compact equipment that not only allows maintaining the sun perpendicularity on the surface of incidence, but also accompany the sun on its azimuthal and zenithal journey. This equipment will be integrated into a single unit, the conventional heating system, allowing hot water availability even in cold weather, without sun or at night. The solar tracking system, is not included in this development. Within the group of university researchers, there is a parallel project developing this device [7].

### 3.2 System design with concentrator.

Taking into account the needs expressed and developments already made in the University [3] some objectives to be met by the design had been established.

First the system must heat sanitary clean drinking water, estimated by existing statistical data, that a temperature of 40 ° C is satisfactory for this use. The system should use solar power and have the ability to store the energy, allowing continuous use. Since it will be used autonomously must have the necessary safety devices and respond to demands of hot water during day or night.

The system has the ability to use conventional energy (electricity or gas) when solar power is not sufficient to meet demand, then responding to the concept of "hybrid" design.

These guidelines led us to design a system to concentrate sunlight on a small area, but that maintains its relative position to the sun constantly, thus taking advantage of better radiation.

To achieve these objectives, it was developed a system that incorporates a parabolic "receiver" (Figure 3) that concentrates solar thermal energy in a focal area, where a heat exchanger plate/tube type is mounted, through which circulates water for domestic use. This fluid (water) is sent to a tank through isolated pipes, which we call "Thermo Tank" and then is taken and pushed again through a recirculation pump to restart the heating cycle, constituting a closed system until effective use. The system allows water to pass also through a "conventional" heater. The latter can be gas or electricity, depending on which source is available and cheaper.



Figure 3. Parabolic concentrator design with in focus heater

This configuration allows controlled and rational use of conventional energy as a part or the whole heat is provided by the solar concentrator-exchanger, then achieving greater efficiency than other methods of heating water. It is essential then, to develop an appropriate control strategy that allows conventional systems activate only when the application is started and turned off when this ends, preventing water mass keep warm without any need.

Between the water heater and the type of "conventional" heater there is a direct connection via an isolated pipe in which a flow sensor is placed, that is used in the control strategy to maintain the water at a constant temperature. The water tank has a level control with a two-way solenoid valve located at the sanitary water supply, allowing maintaining the volume of the Thermo Tank fluid within a certain range. The electric heater will have an electrical resistor, which provides heat only when solar power is not accumulated enough to meet the needs of water to the preset temperature. The gas heater is activated at the same criteria (Figure 4).

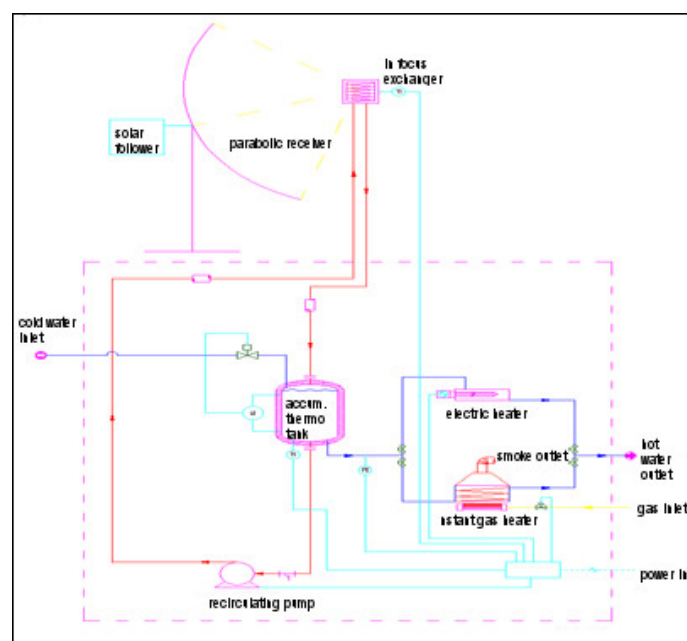

Figure 4. System functional Lay-out.

The loop that regulates the power delivered to the electrical resistor is a function of two variables: water inlet temperature, which is taken into the hot water tank and the flow detector mentioned above. This loop optimizes power consumption since resistor is activated only during hot water demand. Moreover, the power delivered to the resistor is modulated depending on the inlet water temperature and the fluid flow rate, may be in some cases zero power thanks to the use of solar thermal energy.

The gas heater will be a conventional water heater integrated into the system. The amount of burned fuel, and consequently the supplied energy will depend on the demand for hot water and the temperature at which it is accumulated in the tank. Gas regulation is realized through a control valve modulated by a controller, who receives the input signals of flow detection and accumulated water temperature, thereby modulating the amount of fuel.

The other loops are related to the partial deactivation of the process. Remembering that has an active solar tracking system throughout the day, it is proposed to disable it in set schedules for different times of the year. Moreover, when the temperature sensor located in the primary focus records a value less than the minimum profitable energy to maintain operating the recirculation pump, the controller will indicate to stop its operation. This temperature value is obtained through an energy balance which takes into account the solar energy captured and the sanitary water consumption of the recirculation pump into focus. It is proposed to obtain the temperature values for this balance empirically, once the prototype is built, since a difference in estimation of the same capacity would impact in energy use. Finally, through another balance it will be studied if the volume of water contained in the thermo tank after prolonged absence of demand, reach temperatures above  $70^{\circ}\text{C}$  in the interior. In this situation it will be necessary to remove the heat source. The latter will take place, again, ordering the recirculation pump to stop functioning, thus regulating the thermal energy delivered to that tank from the solar source.

Regarding the maximum providing capacity of domestic hot water ( $40^{\circ}\text{C}$ ) that this system is capable to deliver, it will be determined by the energy that can capture and absorb the available antenna (1184 series Brand Prodelin maximum diameter 1.80 m). While it has the support of some external power, this is just to ensure maximum water capacity previously proposed. In future projects the system could be scaled to meet different demands or choose the implementation of more than one of the equipment designed here. It can be concluded that the described system meets the established design objectives. (Figure 5).

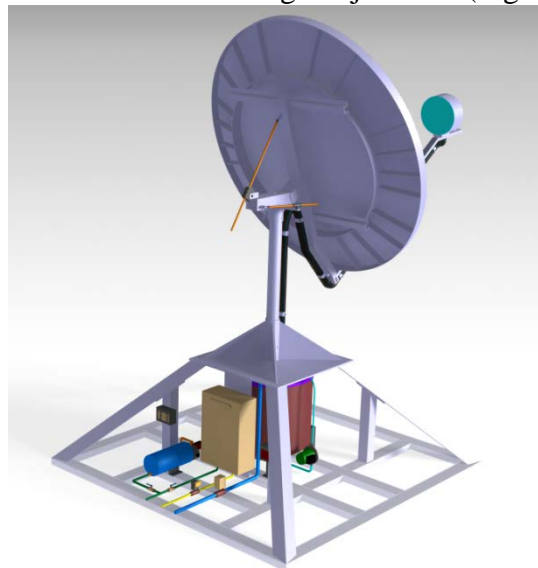

Figure 3. "Hybrid" compact System view with its components and solar concentrator

### 3.3. Theoretical calculation of system components

Based on the proposed concept, it is necessary to develop the theoretical calculation based on the thermodynamic conditions of each of the components to determine dimensions, capacities, operation and final geometry of the assembly. For determining the geometry of the components, it is necessary to establish their characteristics in terms of efficiency and heat exchange. This was achieved by an energy balance. Most of the processes are performed continuously, so that matters refer to the transfer of heat per time unit. The equations described below are associated with the heat balances. They can calculate the quantity of heat that must be transferred to achieve a given process condition on the flow participating in the exchange. These are equations that are associated with a purely thermodynamic pose of the problem, and are completely independent from the equipment design that will focus on the process.

We call  $W$  the mass flow (kg/s) of a stream. The subscript  $h$  indicates the hot fluid and the  $c$  the cold fluid. Also, the subscript 1 indicate the equipment input conditions, while 2 indicates output conditions. When referring to temperatures, to save subscripts, the letter  $T$  is used for the temperatures of hot fluid, whereas  $t$  designates cold fluid temperature. We will call  $Q$  to the amount of heat exchanged per unit of time (J/s). If a hot stream transfers heat to a medium which receives it, it will suffer a decrease in enthalpy that will be:

$$Q = W_h (i_{h1} - i_{h2}) \quad (1)$$

Where  $i$  is the specific enthalpy (J/kg). If such fluid experiences a cooling with no phase change, the enthalpy difference may be expressed as:

$$i_{h1} - i_{h2} = c(T_1 - T_2) \quad (2)$$

Where  $c$  denotes specific heat (J/kg K). We can say then that:

$$Q = W_h c_h (T_1 - T_2) \quad (3)$$

There are other considerations that apply when the process involves phase changes, but will not be applied in this case. To allow heat transfer between two fluids it is necessary that there is a temperature difference between them. The greater the temperature difference, the greater the rate of heat transfer. Furthermore both fluids should be separated by a surface through which heat can be transferred. The surface is called transfer area  $A$ . For example, if one of the fluids is flowing inside a tube, and the other is located outside it, the transfer area is the lateral area of the tube. The higher the transfer area between two fluids, the greater the amount of heat that can be transferred per unit time between them. Therefore the following expression is valid:

$$Q = U \cdot A \cdot \Delta T \quad (4)$$

Where the constant of proportionality  $U$  is called overall coefficient of heat transfer, and  $\Delta T$  is the temperature difference between the two fluids. The above is a kinetics heat transfer equation. It allows calculating the area of equipment necessary to achieve  $Q$  heat transfer between two streams whose temperature difference is  $\Delta T$ . This area depends on the mass transfer coefficient  $U$ , which can be varied by changing the design characteristics of the device. The basic objective of the design, will be to achieve the greatest possible value of the coefficient  $U$  that is compatible with the constraints imposed by the process. In any design problem of heat exchange equipment, the exposed two types of equations (3) and (4) are involved, i.e. there will always be to combine a balance equation with a kinetic equation, which will ultimately decide which allows if the equipment area is sufficient to meet the desired objective. It should be considered the equations to calculate the value of heat transfer coefficient  $U$ . This is calculated on the basis of peculiar ratios. In this paper we adopt a value extracted from table, from studies and trials of CENSOLAR CONICET, which serve to make

first estimations of the process. Then, once built the prototype, we could get this ratio empirically through an analysis of system performance.

The energy balance of a parabolic solar collector, as we have for this work, can be represented by the following equation:

$$Q_{abs} = Q_u + Q_L + dU/dt \quad (5)$$

Where:

$Q_{abs}$ : is the total incident heat absorbed per time unit in the collector/exchanger(W).

$Q_u$  : is the useful heat that is finally transferred to the working fluid (W)

$Q_L$ : is the heat loss to the surroundings by radiation, convection and conduction (W)

$dU/dt$ : the rate of change in internal energy stored in the collector (W), this value is generally very small and is therefore be neglected in the calculation.

Making a more detailed breakdown of the terms of the above equation, we find that each of them can be represented by another equation:

$$Q_{abs} = H_T \cdot Ac \cdot \alpha \cdot \beta \quad (6)$$

$$Q_u = m \cdot Cp \cdot dT / dt \quad (7)$$

$$Q_L = U_{LA} \cdot c \cdot (T_{pm} - T_a) \quad (8)$$

Where:

$H_T$ : incident solar energy on the exchanger ( $W/m^2$ ), this value will depend on solar energy available during the day, the parabolic collector area and the focus area where concentrated solar thermal energy will be used in the process..

$\alpha$ : concentration factor

$Ac$ : effective area of focus ( $m^2$ ).

$\beta$ : the product of the transmittance of the glass and the absorptance of the heat exchanger tube located at the focus, presents the fraction of the solar radiation that is absorbed by the heat exchanger. This value is inherent in the materials used in the heat exchanger located at the focus.

$mCp$ : the heat capacity of the working fluid ( $J/^\circ C$ ).

$U_L$ : loss coefficient ( $W/m^2 \cdot ^\circ C$ )

Substituting equations (5), (6), (7), (8) and rearranging them

$$Qu = Ac \left[ S - U_L (T_{pm} - T_a) \right] \quad (9)$$

Where  $S = H_T \cdot \alpha \cdot \beta$ , that is, the energy available in the heat exchanger per area unit.

This equation is crucial in the analysis of the solar collector operation. The only problem is that the remaining useful heat according to the  $T_{pm}$  (average temperature of the absorber plate, or in our case the absorber tubes) which is difficult to calculate or measure, because it depends on the exchanger design and variables that change continuously over time as solar radiation and temperature of the working fluid entering the collector. To skip this difficulty we will take values that will make the calculation, again, from a conservative position.

#### 4. Developing initial calculation. Prior determination.

For preliminary calculations we considered the above equations and values arising from tables and measurements.

It will be used  $H$  :  $1000 (W/m^2)$  , it is considered  $2,8 m^2$ , then the total energy being captured :  $2800 W$  while  $S_f$ : focus surface that concentrates the energy captured the antenna is  $0.07 m^2$

We will define  $\alpha$  : focus concentration factor =  $0.75$  , this value contemplate the losses due to the irregularity of the reflecting surface that will result in the deviation of solar beams ,

leaving them to converge at the focus and losing some captured power at the antenna. This value also includes the dissemination of the same rays in the atmosphere which is interposed between the collector and the parabolic concentrator and also the possible shift between the actual and the ideal focus.

We will take  $A_c$ : effective area of the heat exchanger =  $0.07 \text{ (m}^2\text{)}$ , although its geometry provides a greater area than shown, it is used to calculate the maximum area limited by the surface focus concentration where the exchanger is. If the exchanger geometry would offer a smaller area than the one mentioned above, we would have to use that magnitude to quantify absorbed energy.

$\beta$  value: 0.8 comes from the copper absorptance used in the heat exchanger and the transmittance of the glass located in the receiving surface of the bulb where the energy is concentrated. It is necessary to use materials having a thermal conductivity greater than  $125 \text{ W/m } ^\circ\text{C}$  and an absorptance greater than 0.9, and must also be made of steel, copper or aluminum, and its minimum thickness is 0.5 mm, 0.2 mm and 0.4 mm respectively, depending on the material.

For  $U_L$ : Below are the Thermal Loss Factors based on the type of solar collector, which we call our concentrator focus. As will be shown later, here we propose a focus vacuum exchanger so it will take to calculate the value of 2 ( $\text{W/m}^2 \text{ } ^\circ\text{C}$ )

Tabla 1. Factores de pérdidas térmicas

Collector Type	Conversion Factor ( $\eta_0$ )	Thermal Loss Factor $U_L$ ( $\text{W/m}^2\text{ } ^\circ\text{C}$ )
Without cover	0.9	15-25
Single cover	0.8	7
Double cover	0.65	5
Selective surface	0.8	5
Vacuum pipes	0.7	2

Source: CENSOLAR (Centro de Estudios de la Energía Solar)

It is necessary to use materials having a thermal conductivity greater than  $125 \text{ W/m}^2 \text{ } ^\circ\text{C}$  and an absorptance greater than 0.9 and must also be made of steel, copper or aluminum, and its minimum thickness is 0.5 mm, 0.2 mm and 0.4 mm respectively, depending on the material.

Thus we have, optical and geometric relationships ideals that:

$$H_T = \frac{2800W}{0,07m^2} = 40000 \frac{W}{m^2} \quad (10)$$

Then, using the coefficients mentioned above, the energy available in the Focus exchanger per area unit is  $S = 40000 \text{ W/m}^2 \times 0.75 \times 0.8 = 24000 \text{ W/m}^2$ .

Considering the loss factor mentioned in the preceding paragraph and the temperature that will meet the copper tubes of the exchanger, the useful heat transferred to the domestic water in the process is applying (9)  $Q_u = 1680W - 19.6W$ .

Within this result, the second term corresponds to losses in focus. It can be seen that the losses due to the type of exchanger are in the order of 1.16%, considerably low taking in account that we applied a mean temperature value in the exchanger tubes of  $150 \text{ } ^\circ\text{C}$ , this being a conservative value. Finally, we conclude that we have applied to the process fluid an amount of energy of  $1660W$ . The energy value obtained is comparable with the one of domestic water heaters.

Although we can find thermo tanks or water heaters specifications with over  $10,000 \text{ W}$ , this is because in such cases it is much energy applied in shorter times to achieve the

desired temperature difference. Latter responds to sudden changes in demand and decreases the total energy used. In this case, the power output will be applied constantly during daylight hours, or while favorable weather conditions exist. The energy obtained is then transmitted to the sanitary water to increase its temperature and then be used.

The desired temperature output at the end of the calculation was set at 40 °C, which is a standard measure of consumption. The inlet temperature is taken at 10 °C, which is a representative value and conservative as in favorable conditions it may be higher. Finally, the maximum temperature reached by the fluid inside the storage tank is 70 °C and this value will also limit the system operation.

In order to simplify the calculations and obtain representative values that demonstrate the technical feasibility of the proposed system, we considered that water heating is performed in the absence of demand from the mentioned initial temperature. Therefore, it has an inventory of water to which solar energy will be applied without the use or replacement of it until it is completed the solar utilization. This consideration would represent the case of a family who leaves home in the morning and returns in the afternoon / evening, thus providing hot water when they arrive at home. Moreover, the specific heat of water is considered constant along the temperature range expected in use.

Then it is calculated the required time needed by the total volume of water stored to go from the inlet temperature (10 °C) to the output desired temperature (40 °C).

For this, it is used the equation (4) and the ratio W and Joule, yielding a time of 3hrs 9min. It is concluded that it is possible to heat the water reserve proposal ( 150 liters ) needed to meet the needs of a town house type , carrying water from 10 ° C to 40 ° C at least in less than a solar day . This analysis is valid in a first step for the central region, in which the solar resource map provides 4.19 hours/day of use during the summer and 3.352 hours/day in winter, both with a constant  $H=1000 \text{ W/m}^2$ . [8].

We calculate the maximum system operation period in the absence of demand, using the equation  $Q = mc \Delta t$  , on the final temperature  $T_f = 70 \text{ }^\circ\text{C}$  , then we get 37,656,000 W. Taking into account the relationship again Joule/W it has to be long enough 6h 18min . In conclusion we can say that the time required to reach the maximum temperature condition in the water heater exceeds the available solar time resource in any of the latitudes of the Argentine territory. However, one must consider that this time is decreased if the initial temperature is higher than the proposed 10 °C. This may be the case where there is a remaining quantity of hot water from the previous day in the tank, so that the initial temperature will be considerably greater . Therefore, there will be a temperature control loop , according to the accumulated temperature in the thermo tank that will regulate the operating time of the circulation pump, thus controlling the amount of energy delivered to the fluid, ensuring that it does not exceed the proposed maximum temperature of 70 ° C.

#### **4. 1 Heat exchanger. Boiler.**

The design of the heat exchanger located at the focus of the receiving antenna will have exterior dimensions obtained from a geometric analysis, taking into count the incidence of solar rays, according to the data sheet from the manufacturer of the receiving antenna. Because it is a parabolic concentrator, it is possible to achieve temperatures above 150 ° C in focus, so it will be necessary to guide the design to a vacuum device, in order to reduce losses. Not all captured energy is used to heat the desired fluid and which one party irrevocably lost heat to the outside air that is in contact with the collector (conduction and convection) and some is lost by radiation because when the collector temperature rises, it issues with more energy than the environment in which it is being caused losses in that regard.

Within the exchanger, absorption tube is a component designed to absorb energy and transfer it to the water available. It will be used for the design copper, whose thermal conductivity is greater than 125 W/m°C and has a greater than 0.9 absorptance, working with



0.2 mm thickness. The finish will be given to the tube is black paint, also for better absorptance . The proposed geometry brings about  $0.15 \text{ m}^2$  of area transfer which is generated by the helical shape of a shaped tube , with the existence of welds and accessories, only found on the input and output connections . It has a cover of transparent material (glass) mounted in front of the absorber, in the upper part of the collector, creating a space (20 to 25 mm ) between the absorber tube and it. It was selected tempered glass 5 mm thick as the cover material. It has better resistance to thermal shock and has greater resistance to mechanical impact and flexural strength, besides having good conditions for reflection and transmittance. (Figure 4)

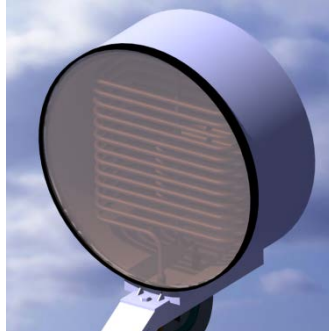

Figure 4. Heater exchanger.

Completing the design it was dimensioned the solar collector base. This structure (Figure 6) is one of the most important aspects of the proposed design. This structure will support the collector antenna, the tracking system, and the heat exchanger located at the focus. Moreover, inside this base are located all the devices that integrate the proposed solar harvesting system. These are: energy storage tank, instantaneous water heaters (1 gas unit and 1 Electric unit), the recirculation pump, a programmable controller, instrumentation, necessary valves and pipes with their insulation. (Figure 5)

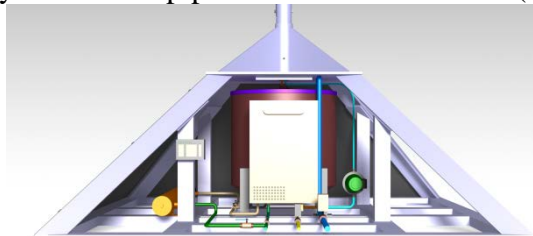

Figure 5. Base structure with components.

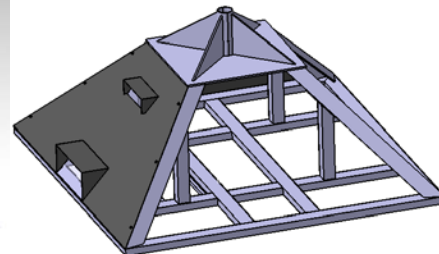

Figure 6. Tubular structure

The complete system design can be observed at Figures 7 and 8 that includes the electric heater and the Gas Thermo tank.

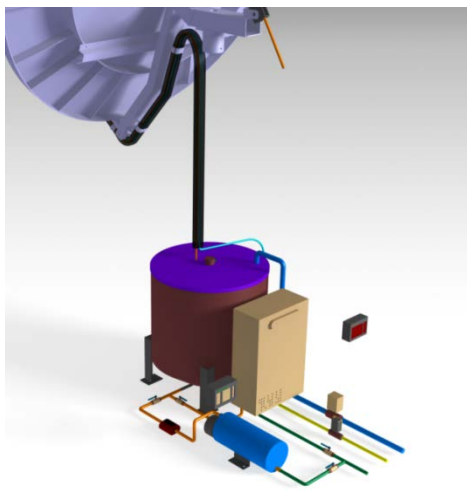

Figure 7. System components

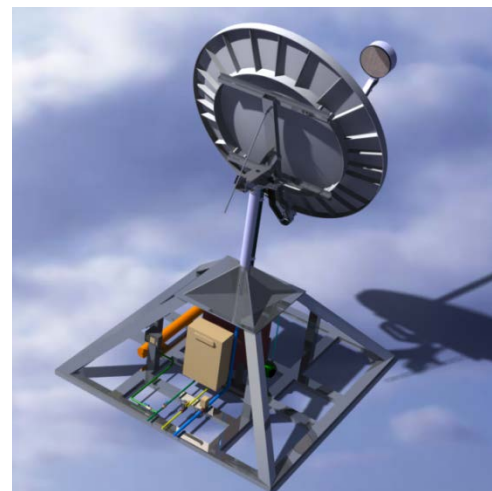

Figure 8. Structure and components.

Water storage tank is proposed with a capacity of 150 liters . While it could be selected any standard tank , the available spaces in the structure of the system are very particular, so a dedicated design is proposed . It will be constructed of stainless steel as it will be in direct contact with the sanitary hot water. It will be consisting of a main body and a lid which can be removed for cleaning the interior. At the top it will have three holes, one for the cold water inlet from the outside, another for the hot water return from the heat exchanger located at the focus and the last for the insertion of the level sensor, which will be detailed later. At the bottom it will be three more holes, one for the suction pump, one for hot water output to the consumer and one for the insertion of a temperature sensor.

One of the main features that should have this tank is the ability to store energy, this is achieved through the insulation to be placed on its outer surface. It is proposed one industrial type called Pyrogel XT, which has a high insulation capacity at low thickness of insulating material.

To complete the design, conventional heating systems should be selected to allow uninterrupted service.

The selected heaters will provide the energy needed to bring the water temperature in the accumulator tank to 40 ° C in order to satisfy proposed demand of 4 people per day, which may be estimated at 150 liters/day of CSW. Sometimes, it will be not necessary to involve them, because as it was demonstrated in the energy balance, the system has the ability to heat the entire inventory of proposed water to the desired temperature. However, we consider the extreme case where the proposed hybrid system will only work with electrical or gas energy input, such would be the case of a few consecutive rainy days.

It is noted that the proposed system, although it has two types of heaters (electric and gas), it can use only one of these sources for the extra energy needed. Namely , it is installed to operate at gas or electric mode, the former being preferred because it is the most economical among the two, mainly if natural gas is available .

For the two heaters, modulating control will be applied to optimize energy use in terms of demand. On this purpose it has a controller, actuators and necessary instrumentation to be described later.

In the case of a gas heater, the selected is one of the BOSCH brand, 660EFO model. It is adapted to the dimensions of the structure and the gas outlet is oriented conveniently for the raised design.

For the electric instantaneous water heater the selected is one of the industrial type WATLOW brand, model CBDNF29R5S , Circulations Heaters Series. It is basically an insulated steel tube containing a power resistance , which will provide the heat necessary to meet the demand . As shown in the table below, the heater type selection is mainly based on the power size of the electrical resistance contained therein. With this data we obtained after the main dimensions of the selected heater

To select the power , we used the calculation proposed by the supplier , in which we introduced the process conditions/use and it is obtained a good estimation that will serve for the selection of the suitable heater (Figure 9)

#### For Heating Flowing Water

Use equation:

$$kW = GPM * x \text{ temperature rise } (^{\circ}F) \times 0.16$$

OR

$$kW = \text{liters/min.} \times \text{temperature rise } (^{\circ}C) \times 0.076$$

Figure 9. Proposed formulas

In this case, again taking into account the most unfavorable condition , this is the inlet temperature at 10 ° C , have an increased temperature of 30 ° C. Moreover, the flow required

to satisfy a standard housing is 4 liters / minute. Is then obtained 4 (liters/min) . 30 (° C) .  
 $0.076 = 9.12 \text{ kW}$ .

Then the heater is selected (Table 2) , whose maximum power is 10.5 kW, which will give us the worst condition a rate of 4.6 liters / min .

Table 1. Instant electric heater selection table

Description	Volts	kW	Ph	# Circ.	Code Number	Del.	Ship Wt. lbs (kg)	"A" Dim. in. (mm)	"B" Dim. in. (mm)	"C" Dim. in. (mm)
<b>1½ inch NPT Screw Plug (FIREBAR)</b>										
<b>90 W/in<sup>2</sup> Steel Tank 1-Incoloy® Elements (14 W/cm<sup>2</sup>)</b>	240	1.5	1	1	<b>CBDNF7R10S</b>	RS	26 (12)	24% (625.5)	15 (381)	3% (79.4)
	480	1.5	1	1	<b>CBDNF7R11S</b>	RS	26 (12)	24% (625.5)	15 (381)	3% (79.4)
	240	3.0	1	1	<b>CBDNF11G10S</b>	RS	26 (12)	24% (625.5)	15 (381)	3% (79.4)
	480	3.0	1	1	<b>CBDNF11G11S</b>	RS	26 (12)	24% (625.5)	15 (381)	3% (79.4)
	240	5.0	3	1	<b>CBDNF16G3S</b>	RS	26 (12)	24% (625.5)	15 (381)	3% (79.4)
	480	5.0	3	1	<b>CBDNF16G5S</b>	RS	26 (12)	24% (625.5)	15 (381)	3% (79.4)
	240	6.5	3	1	<b>CBDNF19G3S</b>	RS	30 (14)	32% (828.7)	23 (584)	3% (79.4)
	480	6.5	3	1	<b>CBDNF19G5S</b>	RS	30 (14)	32% (828.7)	23 (584)	3% (79.4)
	240	8.5	3	1	<b>CBDNF24L3S</b>	RS	31 (14)	32% (828.7)	23 (584)	3% (79.4)
	480	8.5	3	1	<b>CBDNF24L5S</b>	RS	31 (14)	32% (828.7)	23 (584)	3% (79.4)
	240	10.5	3	1	<b>CBDNF29R3S</b>	RS	43 (20)	42% (1082.7)	32 (813)	4% (111.1)
	480	10.5	3	1	<b>CBDNF29R5S</b>	RS	43 (20)	42% (1082.7)	32 (813)	4% (111.1)

## 4.2 Control System

To automate the use of the solar power system designed, it is proposed to use a Programmable Logic Controller (PLC) . The proposal is that the system contains a number of sensors and actuators and control logic that can perform one of these Controllers. The main idea is to centralize all control logic on a single device, both for the operation of the system described in this paper , as for the solar tracking system, that will have the receiving antenna. On this purpose, we studied the quantity and type of inputs and outputs required , as these are the most important variables when selecting the PLC . Moreover, as this is a prototype , it is interesting to have this type of controller as it offers favorable characteristics for the study of process behavior , such as historical data , possibility of raising the process information in real time, the possibility of applying preset modes as PID loops, analyzing their behavior and so on.

Below are the different inputs and outputs necessary to perform the control logic that will automate the proposed system :

- 1 Thermo resistance Input: accumulator tank temperature signal
- 1 Digital Input: Fluid Outflow hot water)
- 1 Analog Output: Modulating electric power applied to the instant heater resistance
- 1 Analog Output: Modulating Gas flow used in instant heater .
- 1 Thermocouple Input: temperature Signal at the exchanger focus.
- 1 Relay Output: pump start .
- 1 Relay Output : to open/close external cold water inlet solenoid valve .
- 1 4-20 mA Analog Input: accumulator tank level indicator signal.

It is estimated to be needed 2 digital inputs for position sensors and 2 digital outputs for actuators of both degrees of freedom.

With these estimated needs, we selected a suitable PLC for this Project.

## 5. Costs

To calculate the mortgage period of the set, we will compare the current thermo tank values ( electric and gas ) adequate for the same demand considering energy costs by type ( electric or gas ) with current market values .

We conducted a survey of the costs (Table 3) of each of the components of the proposed energy harvesting system .

In cases where the components are to be built by order such as the base structure , the exchanger vacuum sealed radiation and the accumulator tank , we considered the cost of the raw materials needed and the cost of skilled labor to build them.

Table 3. Current Cost of the proposed Solar System Components

Current values for Standard Water Heating Equipment	
DESCRIPTION	Cost (U\$D)*
Receiving antenna	\$ 650,00
Recirculation Pump	\$ 120,00
Electric Heater	\$ 300,00
Gas Heater	\$ 450,00
Energy storage tank ( insulated )	\$ 150,00
Radiation heat exchanger vacuum sealed	\$ 160,00
Base Structure (profiles + labor )	\$ 700,00
PLC CPU module	\$ 220,00
PLC Analog Input Expansion Unit	\$ 150,00
PLC Analog Output Expansion Unit	\$ 155,00
Electric Modulation Control Relay	\$ 250,00
Modulating Gas Control Valve	\$ 150,00
Capacitive Level Meter	\$ 90,00
Flow Meter	\$ 50,00
PT- 100 for Tank	\$ 90,00
Thermocouple for Focus	\$ 90,00
Water solenoid valve input	\$ 30,00
butterfly Valve	\$ 10,00
Pipe 1/2 ' isolated	\$ 12,00
DC supply sources	\$ 75,00
Cables	\$ 10,00
AEROLINE insulated copper pipes ( double run 4 meters )	\$ 100,00
<b>TOTAL COST (USD)</b>	<b>\$ 4.012,00</b>

Then we obtained the standard costs of both heater types ; Electric and Gas for the same water demand. (Table 4)

Table 4. Current Costs of Conventional Water Heaters

Current values for Standard Water Heating Equipment	
DESCRIPTION	Cost (U\$D)
Electrical Thermo Tank	\$ 550,00
Gas Thermo Tank	\$ 450,00

## 6. Final Balances

As obtained in the energy balance, the proposed system achieves the heating water volume of 150 liters from an initial temperature of 10°C to 40°C , in a time of 3h 09min with the solar constant of 1000 W/m<sup>2</sup> . This time verifies the system implementation while used in the central region , meeting the hot water consumption of 4 people in a day without the need to provide energy from other sources, such as gas or electricity . Because the proposed system is a forced circulation type , electrical and electronic components has to be energized during operating hours. Moreover conceptually it has to be considered defective insulation losses , since it is not an ideal adiabatic system .

Table 5: Energy Balance for Conventional Heaters

Component Consumption and considerable losses ( W )	
Recirculation pump	75
Controller, Instrumentation and actuators	15
Defective insulation losses	< 5
<b>Total (W)*</b>	<b>95</b>

\*At this stage the power needed for the solar tracking system will not be considered.

The balance is made general and oriented only to harnessed solar energy. The balance, however, do not contemplate the electrical power needed to operate the system. Although this

achieves to heat the water inventory in the proposed time period, it is related to the solar constant used.

It is important to consider that to receive the total daily energy, the system must be active along the whole usable solar day. The proposed base operating time is 8 hours/day, excepting the intervals at which it is detected that the energy collected is less than the minimum to be established empirically, with actual measurements from the prototype. Then the basic operating time will be used to quantify the electrical energy required per day to let work the proposed solar harvesting system.

The proposed system requires per day  $95 \text{ W} \times 8 \text{ hours} = 760 \text{ Wh}$  or  $0.76 \text{ Kw.h}$  of electrical energy for operation. Comparing the results, the proposed system does not totally disregard power for operation. It provides a savings of 87% of this energy, related to that required to heat the same inventory of water under the same conditions through an electric heater (  $5.81 \text{ Kw.h}$  ).

The percentage obtained is a good indicator of the importance of making the proposed solar harvesting system.

## 7. Conclusion

Based on the proposed design, it has been proved that is possible to build an autonomous compact system that allows heating the proposed water reservoir (150 liters , about 40 l/human/day ) needed to meet the requirements of a town house type, bringing the water from  $10 \text{ }^{\circ}\text{C}$  to  $40 \text{ }^{\circ}\text{C}$  at least in less than one solar day . Therefore, this system is ideal to be used in places where there is no prior infrastructure for obtaining hot sanitary water. The system requires minimal maintenance, the same needed by a conventional system, without having a prior training. The complete installation can easily be mounted "in situ", since in the case of having no other power source than the sun, the structure can be simplified by removing unnecessary components. In this way it is only need to connect the cold water inlet and hot water outlet. In case that it will be used as a hybrid system, it would be needed in addition, a connection to the gas and/or power supply. It is under development a complementary economic feasibility study.

## References:

- “*Design and construction of a solar water heater operated by thermosyphon*”(2006). Scientia et Technica, Año XII,Nº 31, UTP.ISSN 0122-1701.
- Placco, Cora; Saravia, Carlos.(2004). “*Solar Collectors for Hot Water*”. INENCO, UNAS-CONICET.
- Zambrano, Daniel; Vitali, Osvaldo. (2010). “*Stirling Engine Development solar concentrator for use in isolated areas*”. CIBIM2009, Las Palmas, Mallorca, España.
- Fernández Diez, Pedro. *Thermal processes in low, medium and high temperature*. <http://libros.redsauce.net/Energiasalternativas/solar/PDFs/01Solar.pdf>.
- Follari J. y A. Fasulo, 1998. *Twenty years with solar water heaters. Progress on Renewable Energy and the Environment*. Vol. 5. 1998. ISSN 0328-932X
- Sixto Guevara Vásquez , 2003. *Theory for the design of solar water heaters* - - UNATSABAR – OPS/CEPIS - Lima,.
- Zambrano, Daniel;Vitali, Armando; Garcia Ramirez, Oskar (2012). “*Development of the structure and a control system for a satellite dish solar use*”.III CAIM 2012.
- Local Energy Situation: Balance and Perspectives of Complex Problems* - Universidad Nacional de Cuyo - Agosto 2004

# POTENTIAL OF RAINWATER HARVESTING IN BUILDINGS TO REDUCE OVER EXTRACTION OF GROUNDWATER IN URBAN AREAS OF BANGLADESH

***Maharam Dakua***

Project Coordinator, ITN-BUET,  
Bangladesh University of Engineering and Technology, Bangladesh

***Fahmida Akhter***

Research Assistant, Bangladesh University of Engineering and Technology, Bangladesh

***Partha Protim Biswas***

***Md. Latifur Rahman Siddique***

***Reyad Morshed Shihab***

Student, Ahsanullah University of Science and Technology, Bangladesh

---

## Abstract

Rainwater harvesting is an ancient technique which is very simple. In countries like Bangladesh, where annual rainfall is high, rainwater could meet a significant amount of total demand. Due to maladaptation to the paradigm of extraction of groundwater without considering the sustainability, people in Dhaka and other urban areas in Bangladesh are still reluctant to use this abundant source. This paradigm has been pushing the water supply scenario of Dhaka city closer to a condition where the city might face permanent water crisis, once the underground aquifers goes down below the pumping level or the aquifers become dry. Also the surface water condition of peripheral rivers of Dhaka city is in poor condition which does not encourage increasing use of surface water in Dhaka city. As an alternative of these options, rainwater harvesting has been considered though majority of the users are not fully aware of its potential to become a source of water. Analysis of the catchment availability and size of storage tanks are needed to find the potential of rainwater harvesting in the building and the capacity of buildings to store rainwater and use it. In this paper, an attempt was made to calculate the potential of rainwater harvesting in large and small premises of Dhaka city. Also the possible financial benefit from rainwater harvesting was also analyzed in this paper which would bring interest of the users.

---

**Keywords:** Rainwater harvesting, catchment, buildings

## Introduction:

Rainwater harvesting is an ancient technique that has been practiced for thousands of years in different part of the world. It has been often found that areas where surface water or groundwater is not available in sufficient amount, rainwater harvesting is the best available option and popular also. In Bangladesh, rainwater harvesting is very much in practice in coastal areas where salinity has left only a few scarcely located ponds as a source of potable water. But in urban cities as well as municipalities, rainwater harvesting is still not a favored option as surface water and ground water are the main sources of water supply system. To carry with this current paradigm, sufficient reserve of good quality ground water and surface water in nearby water bodies is important. But it has been observed in recent past that many of the cities and municipalities in Bangladesh are running out of such sources that have good quality water, mainly during the dry period. Over extraction of groundwater to keep pace with

the increasing demand of water and pollution of surface water through indiscriminate disposal of domestic and industrial waste has forced the water supply authorities in many places to think about new water sources for future. Dhaka, the capital of Bangladesh has been suffering water crisis for a few years. About 87% of its supplied water comes from ground water sources and 13% from peripheral rivers (Khan, 2012). But due to over extraction of ground water, the water table has gone below the pumping level which has resulted in abandoning deep tube wells at many locations. Also due to poor quality of peripheral river water, Dhaka Water Supply and Sewerage Authority (DWASA) cannot think of using these rivers as a potential source for future. In addition to this crisis, the population of Dhaka city is increasing day by day due to migration from rural areas which is putting more pressure on DWASA.

To address this crisis of water sources, rainwater harvesting has been thought as one of the potential alternatives in Bangladesh. Bangladesh has been blessed with huge amount of rainfall every year. A significant portion of the demand during rainy season could be met from this rainwater which would also reduce the pressure from city water supply. But the main challenge identified to use rainwater is the storage system. As people of Dhaka city are used to get water twice every day and the shortage of water source was not in vision of the authority as well as citizens, storing rainwater was not considered during planning and construction of the facilities. The willingness of people to store rainwater has not been found in favor of this potential alternative also (Tabassum, 2013). To overcome these barriers in order to promote rainwater harvesting in Dhaka, analyzing cases and understanding the probable impact of storing rainwater in reduction of groundwater extraction as well as cost reduction would be vital. In this study, an attempt was made to find out the potential of rainwater harvesting in large premises with high water demand as well as in few residential buildings with smaller catchment areas. Volume of water that can be harvested from available rainfall and subsequent reduction of water bill was analyzed in this study. It shows the potential of rainwater harvesting practice as an alternative in future years to address the looming water crisis in Dhaka.

### **Background:**

Due to capital base centralization of Bangladesh, Dhaka has always been the center of development since independence. Lack of proper planning with urbanization and industrialization makes Dhaka city over populated with huge migration each year; polluted and ecologically imbalanced. Dhaka is the 19th mega city in the world and water crisis has become an acute problem in Dhaka city. Dhaka Water Supply and Sewerage Authority (DWASA), established in 1963, is a service oriented autonomous commercial organization in the Public sector, entrusted with the responsibility of providing water supply, sewerage disposal (wastewater), and storm water drainage services to the urban dwellers of this fast-growing metropolitan. It covers more than 360 sq. km service area with a production of almost 2110 million liters per day (MLD) against the present demand of 2250 MLD (Khan, 2012). It has been estimated that water demand in Dhaka with current rate will be 4990 MLD by 2030 (Paul, 2009). DWASA faces a number of challenges. These include unplanned city development and informal settlements, transitioning to using surface water instead of groundwater, and large investment funding (Khan, 2012). Most of the slum areas of this city do not have any legal water supply system.

According to *ibid* (2011), approximately 90% of the city's water supply comes from ground water which is higher than the estimated 87% by DWASA. Institute of Water Modeling (IWM) and DWASA have projected that only 39.5% of city's water demand would be fulfilled in the year around 2030 against the estimated demand of approximately 4990 million liter per day (*ibid*, 2011). It has also been estimated that groundwater sources would contribute about 87% out of that 39.5%.

However, according to various studies, the city's ground water table has been depleting at an alarming rate (Nahian et al, 2013). According to a study conducted by Institute of Water Modeling (Bangladesh), the city's groundwater level has been falling by 3 m/year, which now stands approximately 60 m down below the surface level compared to 10 m in 1970 (Biswas et al, 2010). In another study of Bangladesh Agricultural Development Corporation (BADC), the level has depleted down to 61.18 m below the surface in Dhaka city (ibid, 2010). Also due to severe electricity shortage and rising consumption charge, the option of groundwater extraction has become difficult and costly (The Sydney Morning Herald, 2010; Islam et al, 2010).

As the ground water table is lowering alarmingly, DWASA is attempting to shift towards surface water for new sources. But the water quality of the peripheral rivers of Dhaka city has been severely damaged in recent years due to municipal and industrial untreated wastewater that are discharged into these rivers (Kamal et al, 1999; Subramanian, 2004). In addition to that, the increased rate of urbanization and illegal encroachment has reduced the amount and volume of surface water bodies around Dhaka city (Seraj, 1994; Tawhid, 2004). Most of the small and large scale industries usually dump their wastes directly to the rivers without any treatment or with little treatment. At dry season, the existing treatment technology of Dhaka WASA cannot treat the raw water as per standards (Begum and Ahmmed, 2010). Currently there are three treatment plants working to treat river water in Dhaka. But due to the poor quality of river water, a pre-treatment plant with the existing treatment system was installed in 2012 by DWASA. This has led DWASA to go further upstream to find water of better quality though it would need huge investment as well as the complexity in water supply system would increase.

Considering the adaptive capability and available resources, rainwater harvesting has the potential to become a solution to water crisis in urban areas. In Bangladesh, where average rainfall varies from 1200 mm in the extreme west to over 5000 mm in northeast (WB, 2000), rainwater is considered to be the next option (Haq, 2005) to look into. Generally, urban areas are typically characterized by concentrated demand of water because of its high population density and varied uses of water. In urban perspective, rainwater harvesting appears in different perception than in rural perspective (Haq, 2013). Promotion of rainwater harvesting would face the challenge of unavailability of suitable structures for storing rainwater and should be analyzed in the context of financial benefit. In this paper, typical examples were studied where water consumption is high and also cases were studied for residential buildings to explore the feasibility of harvesting rainwater in the context of financial benefit and reservoir's capacity.

### **Methodology:**

Rainfall is an unpredictable variable to calculate the potential of rainwater harvesting of an area. In this study, average monthly rainfall of 30 years (1980-2010) from Bangladesh Meteorological Department (BMD) was used. Normally water is stored in the underground tank of facilities and it is designed based on the daily demand of that facility. In this study, one Engineering University and four residential buildings (Mohammadpur, Banani, Jatrabari and Baridhara) were studied and its water consumption, storage capacity and potential catchment area were analyzed. Dhaka city has almost 45 private universities like Ahsanullah University of Science and Technology (AUST), with a large amount of consumption each day. Hence, rainwater harvesting in these buildings will reduce pressure on DWASA water supply. Moreover Dhaka city is highly occupied by high-rise buildings and daily consumption of these buildings are getting higher with better life style. Here two duplex buildings (Banani and Baridhara) and two multistoried buildings (Jatrabari and Mohammadpur) were studied that have relatively smaller catchment areas. Within Dhaka City Corporation (DCC) boundary area, 81% of buildings have less area than 2160 ft<sup>2</sup> or 200 m<sup>2</sup> (Tabassum, 2013). Therefore,



the studied buildings would represent a large number of structures of Dhaka city which consumes a significant part of the total daily water supply.

The monthly water bills of all the studied buildings of last one year were collected. From this bills, which are prepared by DWASA based on the water meter reading, monthly water consumption was calculated. Along with that, number of users and their type of use was analyzed to get the theoretical water consumption per day based on the Bangladesh National Building Code (BNBC) guideline.

The rooftop of the buildings was considered as catchment. The total rooftop area was calculated from the design drawings of all the buildings. The rain that falls on this rooftop was considered for calculating the rainfall potential. Rain falling on ground was not considered as it often carries contamination. The capacity of underground storage tank was calculated during survey. The average rainfall was taken as monthly basis and monthly consumption of the buildings was compared to available monthly rainfall. The calculated probable supply of water from rainwater is based on the assumption that rainfall event will be evenly distributed throughout the month. But the analysis based on such assumption may not fully comply with actual scenario as the distribution of rainfall often varies and is not uniform.

Rainwater harvesting potential was measured by using the formula ( $A \cdot R \cdot C$ ) where  $A$  is the catchment area in  $m^2$ ,  $R$  is the average rainfall in mm and  $C$  is the runoff coefficient. For the rooftops of the studied buildings,  $C$  was assumed as 0.8 (Pacey et al, 1989). For calculation of water bills, at first monthly bill was divided by two (50% of bill is for sewerage system). Current water tariff in Dhaka was used to know the monthly consumption of water in thousand liters (Vat was considered). Based on the collected water consumption information, available rainfall, catchment and storage capacity, analyses were made to find the amount of money that could be saved approximately if rainwater was used to the buildings with existing reservoirs capacity.

### **Results and Discussion:**

Ahsanullah University of Science & Technology houses about 6500 students, faculty members and staffs with a water consumption of about 1,306,467 liters per month on average. This huge amount of water is supplied from DWASA which is abstracted by deep tube well. The university complex has plain roof area of about 12,500  $ft^2$ . The building has a rooftop area of 33,000  $ft^2$ . It has underground reservoir of 405,000 L capacity and cumulative volume of its 5 overhead tanks is 598,590 L. Total annual rainwater harvesting potential from the rooftop is 5,788,613 L. The authority paid BDT 523,204 (50% of DWASA bill) for its water consumption in 12 months.

Among other four residential buildings, one has rooftop catchment of 5,040  $ft^2$  with an underground reservoir of 40,752 L capacity in Banani area. Monthly average water consumption of this building is 192,833 L and annual rainwater harvesting potential is 884,021 L. The residents of the building had to pay BDT 32,402 in one year for water bill. The building in Baridhara has catchment area of 4,320  $ft^2$  and the reservoir capacity is 36,377 L. Average monthly water consumption is about 193,083 L. Annual rainwater harvesting potential from this building is 757,732 L and its one year water bill was BDT 28,379. The building studied in Jatrabari has a rooftop catchment of 1,500  $ft^2$  and has underground reservoir of 32,600 L capacity. This has the smallest rooftop among the studied buildings. Average monthly water consumption by its residents is 183,444 L. Annual rainwater harvesting potential in this building is 263,093 L. The residents had to pay BDT 15,756 for water bill in one year. The last building is in Mohammadpur area with a rooftop catchment and reservoir capacity of 2,600  $ft^2$  and 32,600 L respectively. It has average monthly consumption of 630,333 L though annual rainwater harvesting potential is 456,046 L, which indicates that the density is higher in this building compared to other three residential

buildings. The one year water bill for water consumption was found BDT 51,261 for this building.

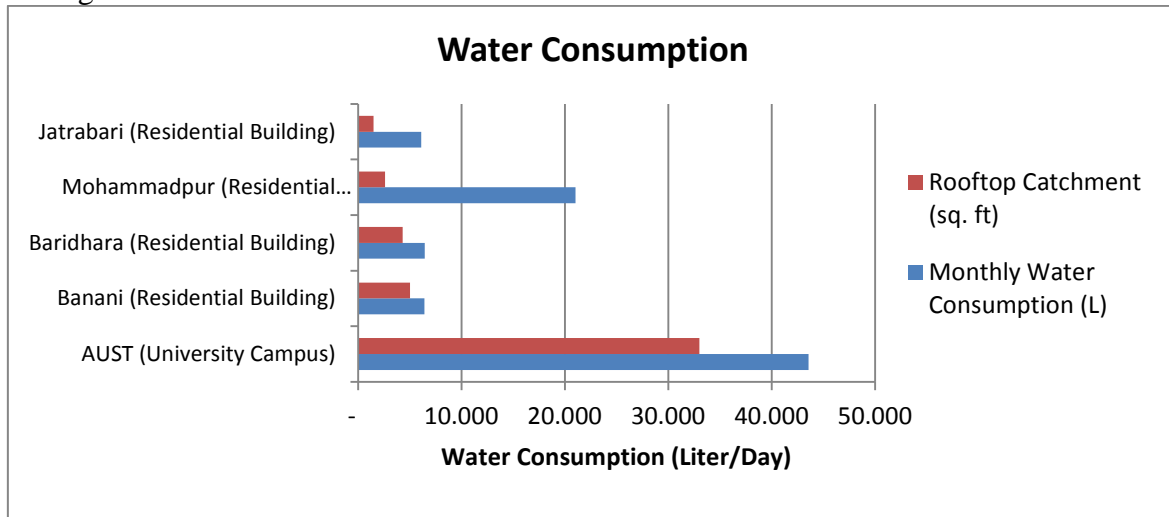

Figure 1: Water consumption of studied buildings and their rooftop catchment area

From figure 1, it can be observed that AUST has the highest water consumption which is due to its large number of users. In comparison, other buildings show less water consumption as they have fewer units. Among the four residential buildings, the one in Mohammadpur shows that its consumption is higher than other three though its catchment area is not big. Rainwater harvesting potential will be less in these types of buildings and the percentage of demand that can be fulfilled by rainwater will be less in these types of buildings which is shown in figure 2 and 3.

Figure 2 shows the amount of money that could be saved if rainwater was used in these buildings. It also shows that use of rainwater will be highest from June to September when rainfall is highest compared to other periods in Bangladesh. This would reduce the extraction of groundwater during this period. During the rainy season, the cumulative water balance after every rainfall event will decide how much water could be harvested. As the reservoir capacity is limited, often heavy rainfall event or persistent rainfall over a few days would cause wastage of rainwater. In that case, all rainwater could not be harvested. Figure 2 gives an idea about the scenario if large reservoirs could be built for storing rainwater of all the rainfall events. It will need to know the cumulative water balance after every month or a certain period to know the maximum size needs to be built for a reservoir.

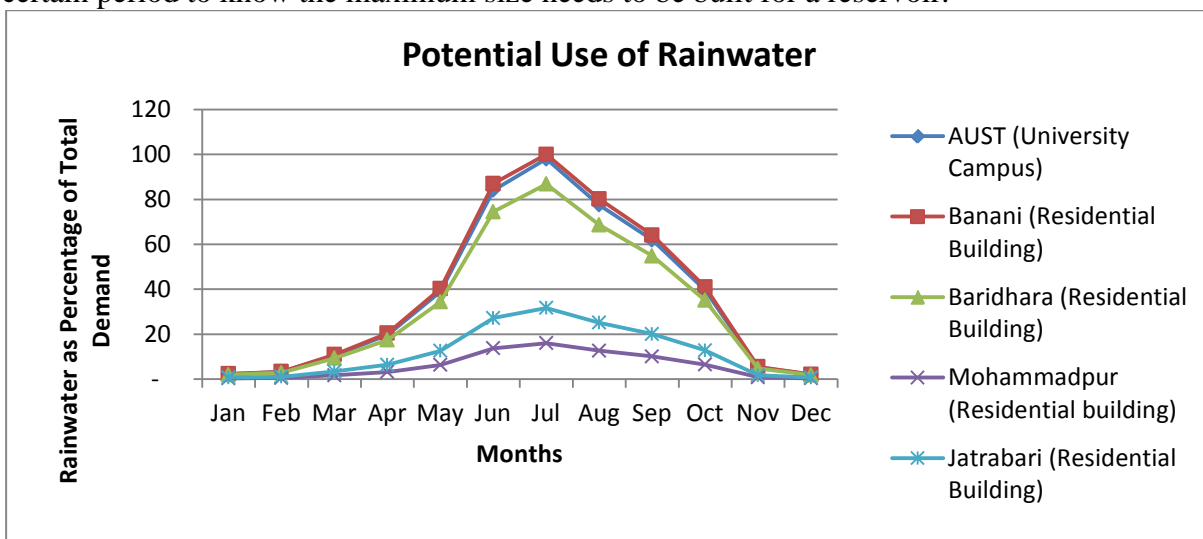

Figure 2: Percentage of demand that can be supplied by rainwater throughout the year

Figure 3 shows that if rainwater could be harvested to its full potential, a lot of money can be saved during rainy seasons. In buildings with comparatively larger catchment ratio to the number of users (AUST, Banani and Baridhara), it was observed that more than 60% of water bill can be saved during the period from May to October.

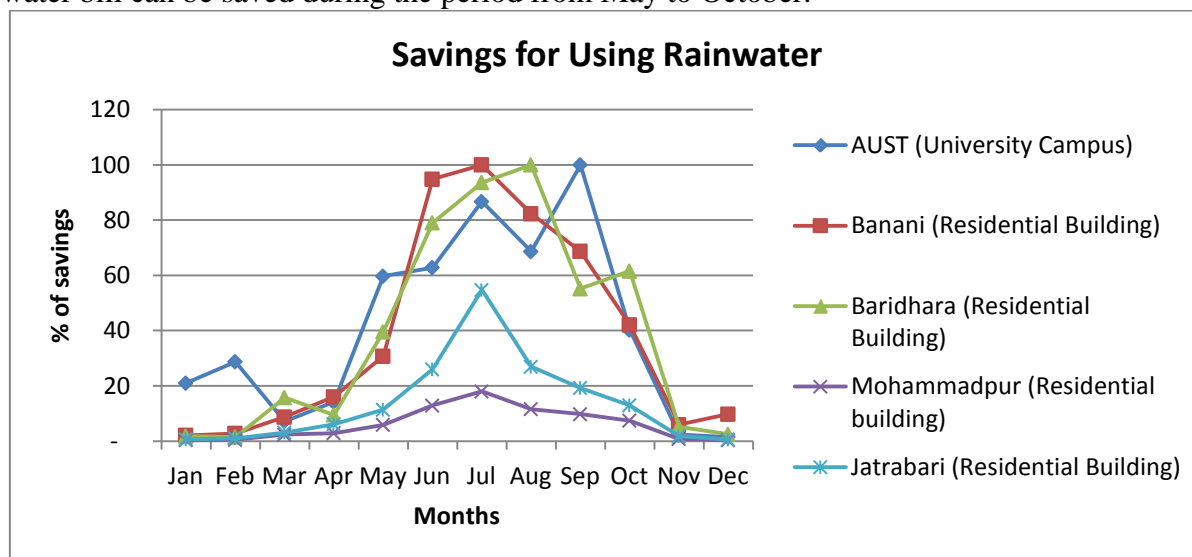

Figure 3: Percentage of water bill could be saved if rainwater harvesting was used to its full potential

### Conclusion:

From this study, it can be said that rainwater harvesting could be very useful and acceptable solution as a low cost technique for the buildings. Ground water extraction will be decreased if we are able to use rainwater harvesting in households of Dhaka city where a reservoir tank of large volume exists. Large premises like AUST campus which consumes a huge amount of everyday which can reduce their dependence on DWASA by rainwater storage. Monthly cost for water consumption will be less by using rainwater harvesting in these buildings which would not take any significant investment also. Also the buildings and apartments should start practicing rainwater harvesting, at least to a certain percentage of their total demand. This would not only reduce their water bills, but also will reduce extraction of groundwater. For further development of the study, water quality test should be performed. Ensuring clean catchment area and storage facilities is the requirement for changing people's perception in favor of rainwater harvesting.

### References:

- Begum, D. A. and Ahmmed, K. M. T., Water Quality Aspects in and around Dhaka City, Proceedings of International Conference on Environmental Aspects of Bangladesh (ICEAB10), Japan, Sept. 2010.
- Biswas, S. K., Mahtab, S. B. and Rahman, M. M., Integrated Water Resources Management Options for Dhaka City, Proceedings of International Conference on Environmental Aspects of Bangladesh, pp 179-181, Accesses on April 2012, Available: <http://benjapan.org/iceab10/47.pdf>
- Haq, S. A., Rainwater Harvesting: Next Option as Source of Water, Proceedings of Third Annual Paper Meet and International Conference on Civil Engineers, IEB, Dhaka, 2005.
- Haq, S. A., Rainwater Management, Presentation in the Workshop on the Draft of Updated Bangladesh National Building Code 1993, Part 8, Chapter 7, Dhaka, 2013.
- Kamal, M. M., Malmgren-Hansen, A. and Badruzzaman, A. B. M., "Assessment of pollution of the River Buriganga, Bangladesh, using a water quality model," Water Sci Technol, vol. 40(2), pp. 129-136, 1999.
- Khan, T. A., Dhaka Water Supply and Sewerage Authority: Performance and Challenges, 2012.

Nahian, S. A., Hyder, K. R. and Hasan, S., Artificial groundwater recharge through rainwater harvesting in urban areas: a study of Niketan area of Dhaka city; Rainwater harvesting in Bangladesh: Potentials, challenges and stakeholders' responses; ISBN: 978-984-90017-6-8, 2013.

Pacey, A. and Cullis, A., Rainwater Harvesting: The collection of rainfall and runoff in rural areas, Intermediate Technology publications, London, 1989.

Paul, R., Water Security in Dhaka City – An Initiative of Government of Bangladesh, 6<sup>th</sup> Governing Council Meeting of Asia Pacific Water Forum (APWF), Singapore, 2009.

Seraj, S. M., Disaster Management in Metropolitan Dhaka for the 21<sup>st</sup> Century, Proceedings of the IDNDR Aichi/Nagoya International Conference, pp. 547-554, 1994. Available: <http://saleksiraj.com/c40.pdf>

Subramanian, M., "Water Quality in South Asia", Asian J Water Environ Pollution, vol. 1(1–2), pp. 41–54, 2004.

Tabassum, A.; Ovi, F. H. and Hanif, M. A., Potentiality of Rainwater Harvesting in Dhaka City: A case study of Kazipara, Mirpur Area, B.URP, 2013.

Tawhid, K. G., Causes and Effects of Water Logging in Dhaka City, Bangladesh, KTH Royal Institute of Technology, 2004.

Available: [http://www2.lwr.kth.se/publikationer/PDF Files/LWR\\_EX\\_04\\_45.PDF](http://www2.lwr.kth.se/publikationer/PDF%20Files/LWR_EX_04_45.PDF)

The Sydney Morning Herald, Bangladesh Water Shortage Sparks Protest, 2010. Available: <http://news.smh.com.au/breaking-news-world/bangladesh-water-shortage-sparks-protest-20100407-rrxn.html>

World Bank Bangladesh, Climate Change and Sustainable Development, Bangladesh Report No. 21104-BD, Rural Development Unit, South Asia Region, World Bank, 2000.

# THE CVD VARIABLES METHOD FOR TAILORING HFCVD CARBON NANOTUBE MORPHOLOGY

*Ashfaq Hussain*

College of Engineering and Computer Science,  
University of Central Florida, Orlando, Florida, United States of America  
Department of Mechanical Engineering, University of Malaya, Kuala Lumpur, Malaysia

---

## Abstract

In research on carbon nanotube growth by hot filament chemical vapor deposition (HFCVD), variations of HFCVD have yielded promising results. However, these systems have used plasma enhancement to tailor nanotube morphology. The use of plasma enhancement has made these HFCVD systems expensive to operate and difficult to scale up. This report presents research results to show that it is possible to use the inherent capabilities of variation in CVD parameters like pressure, temperature, and gas composition to tailor nanotube growth in the HFCVD system without resorting to additional cumbersome techniques, thus retaining the value of HFCVD as a low cost and scalable method.

---

**Keywords:** Carbon nanotubes, chemical vapor deposition, hot filament, morphology

## Introduction

Since the discovery of carbon nanotubes (CNTs) in 1991 [1], they have been found to possess very interesting mechanical, chemical and electrical properties and have been proposed as prime materials for a number of applications. Their property as an excellent field electron emitter has been the basis of their study for applications such as cold cathode flat panel displays and electron guns. A variety of chemical vapor deposition methods have been used to produce carbon nanotube arrays appropriate for field emission applications. Researchers have found that for suitable tailoring of nanotube morphology during chemical vapor deposition of nanotubes for field emission applications, it is necessary to use one or the other of the following procedures: (a) Extensive substrate surface preparation [2-5]. (b) Plasma enhancement combined with HFCVD (PE-HFCVD) [6-14]. These methods, even though they succeed in in-situ growth of good quality carbon nanotubes, are costly and difficult to scale-up. In the case of PE-HFCVD, these two disadvantages accrue to it due to the plasma enhancement part of this method even though HFCVD is inherently a low cost method with scale-up capability. Thus there is a need for using HFCVD for in situ growth of carbon nanotubes in a manner that does not nullify its inherent advantages. In this report, we show that it is possible to meet this objective by controlling the catalyst-assisted growth of carbon nanotubes in HFCVD system purely through variation of CVD parameters like gas composition, pressure and temperature and this variation can therefore be used to tailor the nanotube synthesis. This control in HFCVD depends, as shown here, on the inherent capabilities of changes in CVD variables to modify carbon nanotube morphology during growth.

## Experiment

The hot filament chemical vapor deposition (HFCVD) system used for this investigation has been described elsewhere [15]. The HFCVD reaction chamber pressure was varied between 5 and 100 torr. Temperature variation was between 700°C and 950°C. The

composition of the  $\text{CH}_4:\text{H}_2:\text{Ar}$  precursor gas mixture was varied in such a way that methane contents of 10, 15, and 20 percent were investigated at increasing hydrogen to argon ratios from 10:80 to 60:30. Chemical vapor deposition was carried out on substrates consisting of vacuum-deposited layers of iron-nickel particles and films on silicon wafers. Scanning electron microscope was used to characterize the results.

## Results

The sets of micrographs shown in Figures 1 to 5 show particular instances of some typical results obtained during the investigation of the effects on deposit morphology of change in pressure, temperature, methane content, catalyst density, and  $\text{H}_2:\text{Ar}$  ratio.

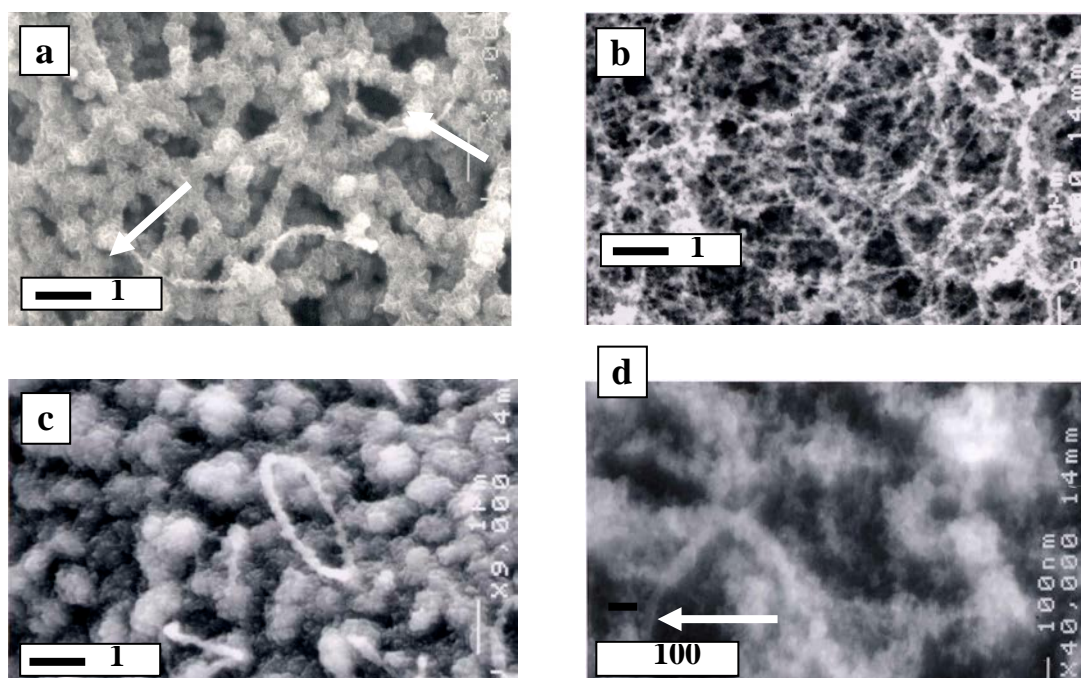

Fig. 1. SEM images showing the effect of pressure on carbon nanotube morphology:  
 (a)  $\text{CH}_4$  content = 10%, Temperature =  $700^\circ\text{C}$ , Pressure = 20 torr,  $\text{H}_2/\text{Ar}$  ratio = 10/80;  
 (b)  $\text{CH}_4$  content = 10%, Temperature =  $700^\circ\text{C}$ , Pressure = 60 torr,  $\text{H}_2/\text{Ar}$  ratio = 10/80;  
 (c)  $\text{CH}_4$  content = 10%, Temperature =  $700^\circ\text{C}$ , Pressure = 100 torr,  $\text{H}_2/\text{Ar}$  ratio = 10/80;  
 (d)  $\text{CH}_4$  content = 10%, Temperature =  $700^\circ\text{C}$ , Pressure = 60 torr,  $\text{H}_2/\text{Ar}$  ratio = 10/80.

Fig. 1a to Fig. 1c shows the effect of change in pressure from 20 to 60 to 100 torr at  $\text{CH}_4:\text{H}_2:\text{Ar}$  composition of 10:10:80 and temperature of  $700^\circ\text{C}$ . At 20 torr pressure (Fig. 1a), the filamentous nature of the chemical vapor deposit is obvious but the structure is very coarse. Two finer filaments on top of the deposit (indicated by arrows) suggest that the coarse filaments have grown by graphite flake accumulation from narrower cores arising from the catalyst particles. Increasing the pressure to 60 torr (Fig. 1b) refines the filamentous structure. Examination of the high magnification micrograph at this pressure (Fig. 1d) reveals the nanotubular cores of the fibers at this pressure (indicated by the arrow in Fig. 1d), which appear to be overlaid with amorphous carbon deposit. A further increase in pressure to 100 torr gives a deposit with very few fibers and a dense graphitic growth over catalyst particles.

Fig. 2a to Fig. 2c shows the effect of change on microstructure in methane content from 10 to 15 to 20 percent at temperature of  $900^\circ\text{C}$ , pressure of 80 torr and hydrogen to argon ratio of 40/50. At 10 percent methane (Fig. 2a) there is not enough carbon deposition to saturate the catalyst particles and cause nanotube formation. 15 percent methane (Fig. 2b) causes formation of nanotubes which are in various stages of nucleation and growth but have a uniform diameter of about 100 nm. Finally at 20 percent methane content (Fig. 2c) the carbon deposition is too high to allow nucleation of nanotubes.

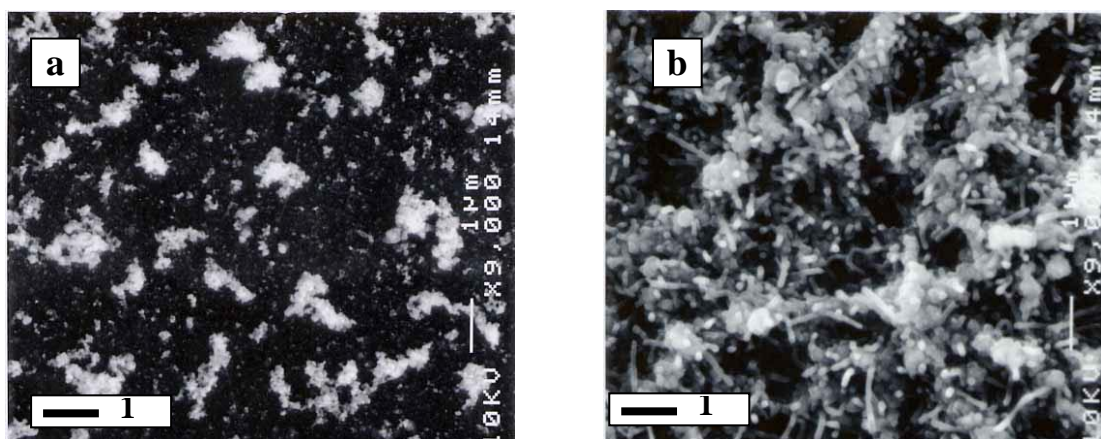

Fig. 2. SEM images showing the effect of methane content on carbon nanotube morphology:

(a)  $\text{CH}_4$  content = 10%, Temperature =  $900^\circ\text{C}$ , Pressure = 80 torr,  $\text{H}_2/\text{Ar}$  ratio = 40/50;

(b)  $\text{CH}_4$  content = 15%, Temperature =  $900^\circ\text{C}$ , Pressure = 80 torr,  $\text{H}_2/\text{Ar}$  ratio = 40/50;

(c)  $\text{CH}_4$  content = 20%, Temperature =  $900^\circ\text{C}$ , Pressure = 80 torr,  $\text{H}_2/\text{Ar}$  ratio = 40/50.

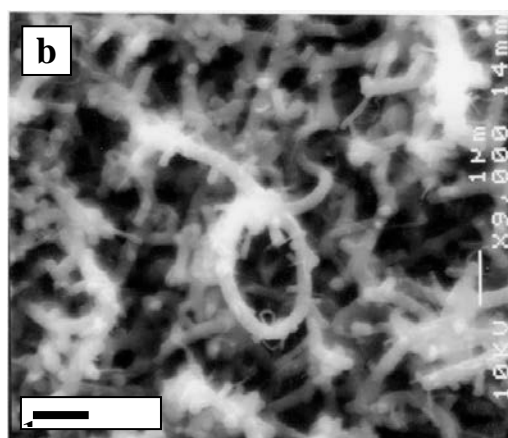
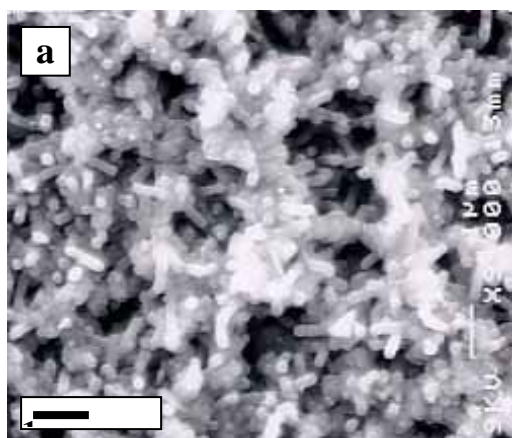
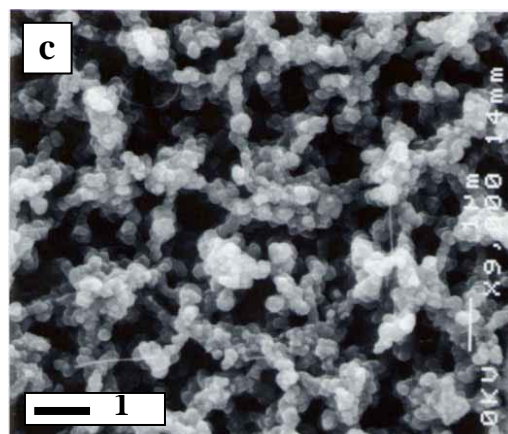

Fig. 3. SEM images showing the effect of temperature on carbon nanotube morphology:

(a)  $\text{CH}_4$  content = 20%, Temperature =  $900^\circ\text{C}$ , Pressure = 60 torr,  $\text{H}_2/\text{Ar}$  ratio = 30/60;

(b)  $\text{CH}_4$  content = 20%, Temperature =  $950^\circ\text{C}$ , Pressure = 60 torr,  $\text{H}_2/\text{Ar}$  ratio = 30/60.

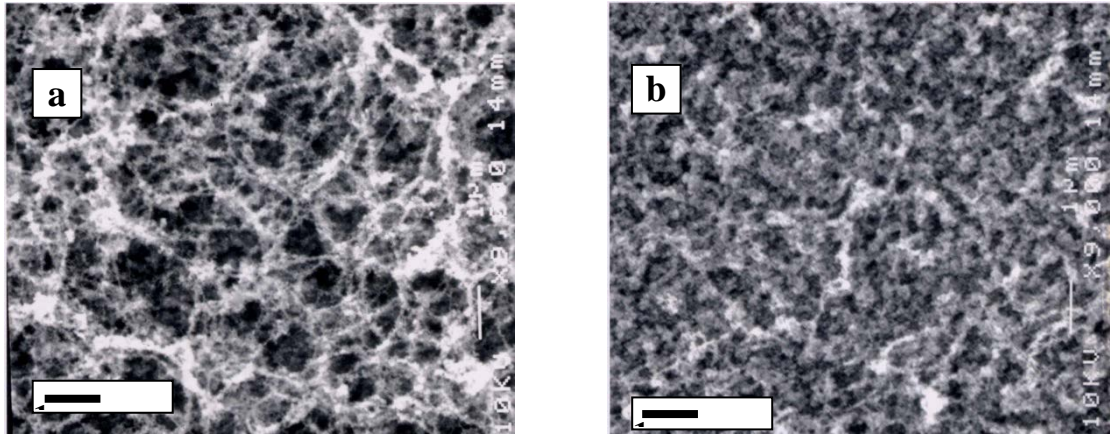

Fig. 4. SEM images showing the effect of temperature on carbon nanotube morphology:  
 (a) CH<sub>4</sub> content = 20%, Temperature = 900°C, Pressure = 60 torr, H<sub>2</sub>/Ar ratio = 30/60;  
 (b) CH<sub>4</sub> content = 20%, Temperature = 900°C, Pressure = 60 torr, H<sub>2</sub>/Ar ratio = 30/60.

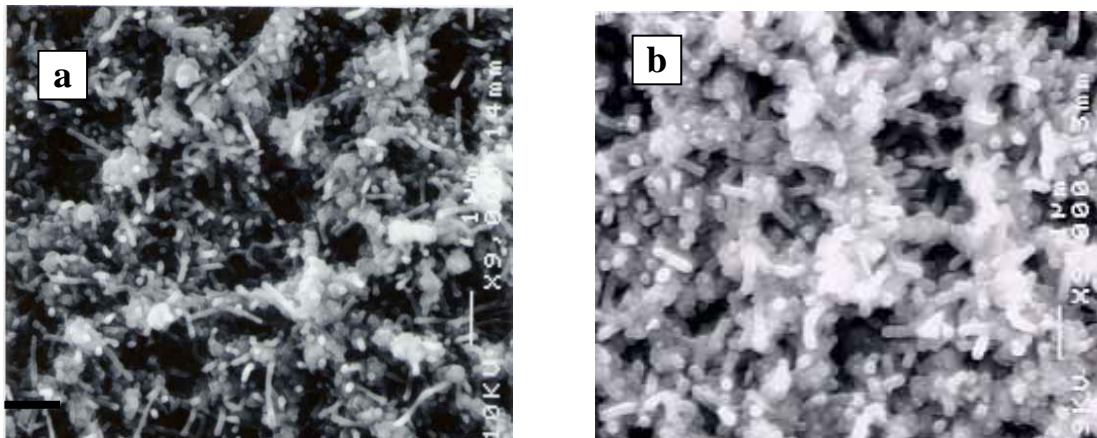
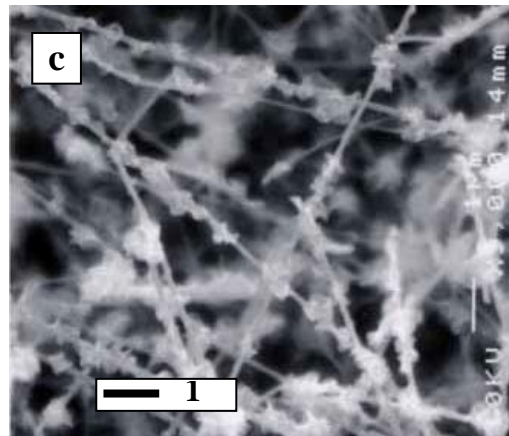

Fig. 5. SEM images showing the effect of H<sub>2</sub>/Ar ratio on carbon nanotube morphology:  
 (a) CH<sub>4</sub> content = 15%, Temperature = 900°C, Pressure = 80 torr, H<sub>2</sub>/Ar ratio = 40/50;  
 (b) CH<sub>4</sub> content = 15%, Temperature = 900°C, Pressure = 80 torr, H<sub>2</sub>/Ar ratio = 50/40, Magnification = X9,000;  
 (c) Same CVD conditions as in (b) at a magnification of X1,000.



The effect of change in temperature is disclosed in Fig. 3. As the temperature is increased from 900 to 950°C (Fig. 3a to Fig. 3b) at 15 percent methane content, 60 torr pressure, and hydrogen to argon ratio of 30/60, it is found that there is a spurt in thickness and growth of nanotubes from the lower to the higher temperature.

Typical effect of change in catalyst density and thickness is represented by the transition shown in Fig. 4a to Fig. 4b from Fe-Ni particle density to Fe-Ni layer density at 20 percent methane content, hydrogen to argon ratio of 30/60, temperature of 900°C, and pressure of 60 torr. The thickness of nanotubes in Fig. 4b is about twice that of nanotubes in



Fig. 4a but there is no change in their length. This is unlike the change in nanotube morphology due to temperature increase where both thickness and length had increased.

Regarding the effect of a change in hydrogen to argon ratio, it was found that an increase in this ratio, resulting in an increase in atomic hydrogen etching effect, would deteriorate an already fine fibrous structure (as shown in the change from 10/80 to 30/60 of this value in Fig. 6a to Fig. 6b at 10 percent methane content, 700°C temperature and 60 torr pressure) but would enhance tubular growth if it had the effect of etching away excess graphitic layers on top of growing nanotubes (as shown in the transition from 40/50 to 50/40 of hydrogen to argon ratio in Fig. 5a to Fig. 5b-c at 15 percent methane, 900°C temperature, and 80 torr pressure).

## Discussion

In the pressure effect sequence (Fig. 1), the nanotubes forming the cores of the fibrous structures at 20 and 60 torr pressures have the same thickness, around 40 to 50 nm. What differentiates the two structures is the manner in which carbon deposition occurs over these core nanotubes in the two cases. Under nanotube growth promoting conditions the nanotubes increase in thickness by addition of graphitic walls to their structure at the same time as their length increases, even though increase in the former dimension is more gradual than the latter. The process of wall addition depends on diffusion and precipitation of carbon around the nanotubes and is highly temperature and pressure dependent. There is evidence that in the pressure range between 10 and 50 torr, as the deposition temperature is lowered below 1600°C, there is substantial increase in interlayer spacing of deposited graphite [16]. At temperature of 700°C and 20 torr pressure graphite can only form around the nanotube cores in the form of widely spaced, crumpled, and overlapping flakes, resulting in the coarse filaments observed. Increase in pressure to 60 torr at the same temperature prevents graphite formation from the deposited carbon and accumulation of amorphous carbon around the cores results, giving finer filaments than at 20 torr. Pressure of 100 torr causes deposited carbon to form dense graphitic growth over catalyst particles, suppressing most nanotube growth and resulting in a hillock-type structure.

Methane in the precursor gas mixture has to undergo dissociation before the released carbon species can dissolve into catalyst metal and reappear as crystalline graphite upon saturation. At a relatively low level of methane content, only enough carbon is processed to lead to growth of some graphitic layers on catalyst particles (Fig. 2a). As the methane content is raised, the rate of carbon being processed into graphitic layers is increased so that the number of graphitic layers reaches the target necessary for nucleation and growth of nanotubes (Fig. 2b). If the methane content is raised upto a level where the rate of carbon being deposited is beyond the absorption capacity of catalyst particles, the excess carbon will begin to accumulate as amorphous carbon (Fig. 2c), a process which has also been called 'carbonization', as opposed to the process of graphitic layer formation known as graphitization. Even though catalyst particles are mostly covered with amorphous carbon at this methane content, the process of graphitization is seen not to stop completely. As disclosed in Fig. 2c, graphitization and nanotube formation may still take place over small uncovered catalyst particle surfaces where the combination of appropriate graphitization level and catalyst metal grain size will satisfy the nanotube nucleation and growth requirements, giving rise to a thin population of fine nanotubes. From the uniformity in thickness of these

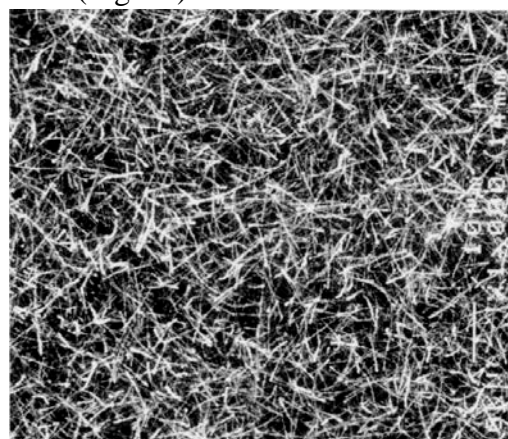

fine nanotubes it can be inferred that there is a unique combination of graphitization level and grain size under the given set of conditions which is giving rise to these nanotubes.

The general increase in thickness and length of nanotubes with increase in temperature (Fig. 3) can be understood in terms of the effects that temperature increase will have on growth conditions. Major effects of the temperature increase include: (a) Greater solubility of carbon in Fe-Ni catalyst particles. (b) Increase in diffusion of carbon atoms within and on the surface of catalyst particles. (c) Increase in the rate of graphitization because of effects (a) and (b). (d) Increase in plasticity of catalyst metal particles. The average nanotube thickness is around 160 nm at 900°C (Fig. 3a) and 230 nm at 950°C

(Fig. 3b). Carbon solubility limits in 50:50 Fe-Ni at 900°C and 950°C are approximately 0.15 wt% and 0.20 wt% respectively [17]. There appears to be a close correlation between the proportion of nanotube thickness increase and increase of carbon solubility in Fe-Ni with increase in temperature. The increase in graphitization resulting from greater C solubility at higher temperatures will render larger grains suitable for nanotube formation because greater number of graphitic layers covering these grains will possess the increased combined elastic stress required for this formation. The increase in plasticity of the catalyst particles with increasing temperature would enhance this effect. Thus, thicker nanotubes will result at higher temperatures.

The change in nanotube morphology due to change in catalyst density (Fig. 4a to Fig. 4b) appears to have resulted from difference in grain size and carbon absorption capacity between the catalyst particle layer and catalyst film layer. The low density particle layer with lower absorption capacity and smaller grain size will have lower graphitization and thinner nanotubes as opposed to the film layer which has greater density and absorption capacity and will give rise to higher graphitization and thicker nanotubes. As noted in the results section, the catalyst density increase effect increases the thickness of nanotubes but not their length whereas the temperature increase effect increases both the thickness and length of nanotubes. The reason for this difference lies in the fact that catalyst density increase enhances only the absorption of carbon into catalyst metal but temperature increase enhances both absorption of carbon atoms into catalyst metal as well as their diffusion.

The etching effect of atomic hydrogen produced by dissociation of hydrogen gas at the tungsten filament and the dilution of this etching effect by argon gas are the two opposing effects represented by the variation in hydrogen to argon ratio. How this etching effect interacts with graphitic layers on catalyst particles determines how hydrogen to argon ratio affects nanotube growth. According to the generally accepted nanotube growth mechanism, a certain number of graphitic layers around a grain will have just enough elastic stress to force a cylindrical shape on both the graphitic layers and the catalyst grain, giving rise to nanotube nucleation. If the number of graphitic layers is less than this threshold number, not enough stress will exist for nanotube nucleation whereas build-up of graphitic layers above that limit will require growth of nanotubes thicker than could be justified by availability of graphite recrystallizing from the catalyst metal. Increase in hydrogen to argon ratio will have the effect of etching out graphitic layers, thus allowing nanotube growth in the latter case (Fig. 5a to Fig. 5b). In case where nanotubes of fine dimensions pre-exist in the microstructure, an increase in hydrogen to argon ratio will wipe them out (Fig. 6a to Fig. 6b). The evolution of a rich, smooth-walled and uniform-diameter growth of nanotubes after adjustment of H<sub>2</sub>/Ar ratio in Fig. 5b (Fig. 5c is another view of this structure at a different magnification) from the microstructure in Fig. 5a which itself resulted from adjustments in CVD variables, represents a clear case of using the inherent capabilities of CVD parameter variation to promote nanotube growth unaided by any other technique.

## Conclusion

Systematic variation of CH<sub>4</sub>-H<sub>2</sub>-Ar gas mixture composition, pressure, temperature, and substrate catalyst density were carried out in a hot filament chemical vapor deposition (HFCVD) system on Fe-Ni deposited silicon substrates to find the role of these variables on carbon nanotube growth morphology. The following nanotube-tailoring effects were found: (a) Increase in pressure in general could be used to improve nanotube formation but pressures above 90 torr tended to wipe out nanostructural features. (b) Increase in methane content under the right conditions could be used to supply carbon for nanotube formation and speed up their growth but beyond that limit would kill tubular formation. (c) Increase or decrease in temperature could be used to accelerate or decelerate growth and thickness of nanotubes. (d) Change in catalyst layer density could be used to change the nanotube diameter. (e) Increase in etching effect represented by the increase in H<sub>2</sub>/Ar ratio could be used to promote nanotube growth in those cases where the etching effect released tube nuclei from overlayers of material stunting their growth but the increase of this ratio could also be used to etch out existing fine nanofeatures where necessary. The application of the etching effect principle shown in Fig. 5a-c resulted in a dense growth of smooth-walled, uniform-diameter nanotubes.

We thus conclude that the variation of CVD parameters offers us a rich assortment of effects which can be used to tailor the nanotube morphology in the HFCVD system quite independent of the use of additional techniques like plasma enhancement which make HFCVD costly and difficult to scale up.

## References:

- S. Iijima: Nature Vol. 354 (1991), p. 56.  
W.Z. Li, S.S. Xie, L.X. Qian, B.H. Chang, B.S. Zhou, W.Y. Zhou, R.A. Zhao and G. Wang: Science Vol. 274 (1996), p. 1701.  
M. Terrones, N. Grobert, J. Olivarres, J.P. Zhang, H. Terrones, K. Kordatos, W.K. Hsu, J.P. Hare, P.D. Townsend, K. Prassides, A.K. Cheetham, H.W. Kroto and D.R.M. Walton: Nature Vol. 388 (1997), p. 52.  
G.L. Che, B.B. Lakshmi, E.R. Fisher and C.R. Martin: Nature Vol. 393 (1998), p. 346.  
S. Fan, M.G. Chapline, N.R. Franklin, T.W. Tombler, A.M. Cassell and H. Dai: Science Vol. 283 (1999), p. 512.  
Y. Chen, D.T. Shaw and L. Guo: Appl. Phys. Lett. Vol. 76 (2000), p. 2469.  
F. Ren, Z.P. Huang, J.W. Xu, J.H. Wang, P. Bush, M.P. Siegal and P.N. Provencio: Science Vol. 282 (1998), p. 1105.  
Z.P. Huang, J.W. Xu, Z.F. Ren, J.H. Wang, M.P. Siegal and P.N. Provencio: Appl. Phys. Lett. Vol. 73 (1998), p. 3845.  
Z.F. Ren, Z.P. Huang, D.Z. Wang, J.G. Wen, J.W. Xu, J.H. Wang, L.E. Calvet, J. Chen, J.F. Klemic and M.A. Reed: Appl. Phys. Lett. Vol. 75 (1999), p. 1086.  
Y. Chen, L. Guo, S. Patel and D.T. Shaw: J. Mater. Sci. Vol. 35 (2000), p. 5517.  
J. Yu, X.D. Bai, J. Ahn, S.F. Yoon, E.G. Wang: Chem. Phys. Lett. Vol. 323 (2000), p. 529.

# A SURVEY OF ANT COLONY BASED ROUTING ALGORITHMS FOR MANET

*Dharmendra Sutariya, M.Tech*

Dept. of Computer Engineering, B. S. Patel Polytechnic, Gujarat, India

*Pariza Kamboj, PhD*

Dept. of Computer Eng., Sarvajani College of Engineering & Technology, Gujarat, India

---

## Abstract

A Mobile ad hoc network (MANET) is a collection of wireless mobile nodes which dynamically join the network and cooperate with each other for multi-hop communication in absence of infrastructure or centralized administration. Routing in MANET is specially challenging due to the variation of network characteristic like traffic load and topology may vary in stochastic and time varying manner. Swarm Intelligence (SI) based techniques such as Ant Colony Optimization (ACO) algorithms have shown to be a good technique for developing routing algorithms for ad hoc networks. Ant based routing algorithms are based on the foraging behaviour of ants. In recent years several ant colony optimization based algorithms were introduced to solve multi constraint QoS routing problems of ad hoc network. They are more robust, reliable and scalable compared to the conventional routing algorithms available in ad hoc network. In this paper, survey of various ant based routing algorithms is done and have been summarize with various attributes to provide a status of research work done in this field.

---

**Keywords:** Mobile ad hoc network (MANET), routing protocols, ant colony optimization (ACO)

## Introduction:

A Mobile ad hoc network (MANET) is a class of wireless network where mobile nodes communicate with each other without any pre-existing infrastructure network and centralized control. In MANET, communications between neighbouring nodes are done directly while the remote nodes are based on multihop wireless links. Mobile nodes in the network not only acts as hosts but also acts as source of data, destination for data and a forwarder of the data. Besides that they also functions as network router that discover and maintain routes to other nodes in the network. With the use of routing protocol, nodes are capable of communicating with other nodes in the dynamic environment of MANET. Routing in MANET is challenging in the absence of central coordinator as compared to other wireless networks where base station or fixed routers manage routing decisions. Designing of routing protocol in ad hoc network depends on various factors like mobility, bandwidth, resource constraints, communication environment etc. Types of MANET applications and inherent characteristic make data routing quite challenging and general purpose ad hoc network routing protocols cannot work efficiently with it. For effective routing, MANET protocol should provide low control overhead, effective adaption to topological changes, low packet delays, high throughput and optimized battery power utilization. The balance of all these conflicting objectives is very hard. For the optimization of the stated objectives, Swarm intelligent based meta-heuristics approach ACO is more promising than other algorithms in MANETs.

The paper is organized as follows. Section 2 describes basic principles of ant colony optimization. Section 3 describes survey of ant colony based algorithms. Section 4 describes comparison of algorithms in terms of structure attributes, performance metrics and network parameters. Section 5 concludes the paper.

### Ant Colony Optimization:

Swarm intelligence (SI) is a kind of artificial intelligence that aims to simulate the swarms behaviour such as ant colonies, honey bees, bird flocks, particle swarm optimization and artificial immune system etc. Ant Colony Optimization (ACO) is a class of optimization algorithms, inspired by an organized collaborative behaviour of ants. Ants are creatures of nature with limited intelligence, which are wandering around their nests to forage for food. The ant colony optimization algorithmic approach models the concept of food foraging, nest building, division of labour, cooperative support, self assembly and cemetery organization of real ants for the meta-heuristic approaches [Z. Ali and W. Shahzad, 2013]. ACO has been formalized in to a meta-heuristic computational approach by Marco Dorigo in 1996. While finding root from nest (source) to food (destination), ants communicate with other ants by depositing traces of pheromone (chemical substance) as they walk along their path. This indirect form of communication is called as stigmergy. As more ants travel over a particular path, the concentration of pheromone increases along that path. Pheromone along a path gradually evaporates, decreasing their concentration on that path. Among the multiple path between nest and food ants select the single optimal path on the basis of maximum pheromone concentration along the path and some heuristic functions. In [S. Mangai, A. Tamilarasi and C. Venkatesh, 2008], ACO algorithm is defined as following:

#### Algorithm 1: ANT Colony based Optimization

**Input:** An instance  $x$  of a combine optimization problem

**While** termination condition not met do

**Schedule activities**

Ant based solution construction ( )

Pheromone update ( )

Daemon actions ( )

**End scheduled activities**

$S_{best}$   $\rightarrow$  best solution in the population of solutions

**End while**

**Output:**  $S_{best}$  candidate to optimal solution for  $x$

*Construct Solutions* chooses a subset from the set of components. The solution begins with an empty partial solution and then at each construction step a feasible component is added in that. The choice of the next feasible component is made by the path selection equation which depends on the ant algorithm system being used. *Update Pheromones* serves two tasks: To increase the pheromone values of the components which are good, and to decrease the pheromone values of the components which are bad. The pheromone decrease is achieved through evaporation. Many different algorithms have been proposed with different pheromone update equations. *Daemon Actions* are usually used to perform centralized actions that cannot be performed by a single ant and that may be problem specific. This action decides to deposit extra pheromone on the solution components that belong to the best solution.

The distributed nature of network routing is well matched with multi-agent nature of ACO algorithms. The set of core properties [M. Dorigo, M. Birattari and T. Stützle, 2006] that characterizes ACO instances for routing problems are: a) provides traffic-adaptive and multipath routing b) relying on both passive and active information monitoring and gathering c) making use of stochastic components d) not allowing local estimates to have global impact e) setting up paths in a less selfish way than in pure shortest path schemes favouring load balancing and f) showing limited sensitivity to parameter settings.

### **Survey of Ant Colony Based Algorithms:**

In this section, various research achievements for unicast and multicast routing protocol with ant colony optimization are defined.

S. Mangai et al. (2008) proposed Dynamic Core based Multicast Protocol (DCMP) which is source initiated multicast protocol implemented using ant colony optimization. In DCMP, the number of source nodes which floods join request packets are reduced, thereby reducing the number of forwarding nodes. In DCMP, there are three type of sources named - passive sources, active sources and core active sources. Mesh maintenance is soft state similar to that of On Demand Multicast Routing Protocol (ODMRP). In NS2, 50 nodes move in the region of  $1000*1000 \text{ m}^2$  with node speed between 0 to 20 m/s and pause time is 10 seconds. Simulation time is taken as 600 seconds and Constant Bit Rate (CBR) traffic load is 10 packets/second. Result shows that packet delivery ratio is increased and control overhead is decreased with respect to node speed.

Kewen Li et al. (2008) proposed an improved ant colony based algorithm for multi-constrained QoS routing. During the searching process, two groups of ant carry out the searching separately. One finds the optimal path from the source to destination and other finds the path from destination to source. After one search, they exchange information to avoid stagnation. The optimal one is selected from the two paths combining multi-constrained QoS. In every new search process, the previous received optimal path and the probability of the path are saved. In the selection of next node by each ant, the probability of previous search is introduced to speed up the search process. The path which meets QoS constraints and has minimum cost is the optimal path and the smallest price multicast tree is output. For the simulation purpose 8 nodes are taken and characteristics of the node are described with four vectors as (delay, delay jitter, bandwidth, cost). Proposed algorithm increases delay and reduces cost compared to mini delay algorithm (which provides minimum delay). It increases cost and reduces delay compared to mini cost algorithm (which provides minimum cost).

Wenyng Liu et al. (2009) proposed hybrid multicast routing protocol to support QoS parameters with ACO. According to the characteristics of mobile networks, Improved Zone Routing Protocol (ZRP) is used to get optimized network topology which meets the QoS requirements. The multicast path is calculated according to the topology. Then the optimal multicast tree is established by using ant colony algorithm. 50 nodes move in the region of  $1000*1000 \text{ m}^2$  with speed of 0 to 10 m/s and transmission radius of 250 m. Channel capacity is of 2 Mbps and simulation time is taken as 500 seconds. Performance of the algorithm is compared with the Ad hoc On demand Distance Vector (AODV) and Destination Sequence Distance Vector (DSDV) protocols. The method can effectively reduce the average delay and improve the rate of packet delivery.

Bencan Gong et al. (2007) proposed approach of constructing a multicast tree where ants orderly set out from every destination node, search the multicast tree, then pick out an optimal path and put nodes and edges along the path into the tree. When all destination nodes have joined, the multicast tree is generated. It considers multiple QoS metrics such as cost, delay and jitter. It ensures that the generated multicast tree satisfies QoS requirements and has a lot of advantages including small overhead, good expansibility and distributed characteristic.

A. Sabari et al. (2009) proposed an Ant agent based Adaptive Multicast Routing Protocol (AAMRP). It exploits group member's desire to simplify multicast routing and invoke broadcast operations in appropriate localized regimes. By reducing the number of group members that participate in the construction of the multicast structure and by providing robustness to mobility based on broadcasts in densely clustered local regions. The proposed protocol achieves packet delivery statistics that are comparable to a pure multicast protocol but with significantly lower overhead. AAMRP dynamically identifies and organizes the group members into clusters which correspond to areas of high group member affinity. In each of these "dense" neighbourhoods, one of the group members is selected to be a cluster

leader. Cluster leader establishes a sparse multicast structure among themselves and the source. They use broadcasting to deliver the packets to other group members in their cluster. Each group member in AAMRP can be in 3 states. It can be a temporary node just joining the session, it can be a cluster leader or it can simply be the member of a cluster. Each node maintains a Group Member Table (GMTTable) and cluster leader maintains a Cluster Member Table (CMTable). In NS2 simulator 25, 50, 75 and 100 nodes move in the region of  $600 \times 600 \text{ m}^2$  with the speed of 10 m/s. Random Way Point (RWP) model is considered with CBR traffic and node transmission radius is set to 250 m for simulations. Control overhead, routing load, end-to-end delay and packet delivery fraction are performance metrics evaluated with respect to varying number of nodes and group size. The method effectively increases packet delivery fraction and reduce the end-to-end delay and routing load.

Bencan Gong et al. (2007) proposed ant algorithm with multiple constraints. Approach of constructing a multicast tree is to find the shortest paths from the source to each destination separately using ant algorithm based on state transition rule and pheromone rule. Then it merge the resulting paths to form a multicast tree. Algorithm can find the optimal or near-optimal solution quickly. For simulation experiments 100 nodes are taken as network size and cost of edge is taken as distance between two nodes. Delay of edge is taken in range of (0, 10] and delay jitter of edge is in range of (0, 5]. Test result shows that the algorithm can construct the multicast tree that minimizes the total cost in a few iterations and performs better than ACO algorithm.

Kewen Li et al. (2008), established a multi constrained QoS routing model with mobile agent as the node. The effect of QoS parameters are determined by orthogonal experiment of statistical methods. According to the general scope of the search path, a suitable orthogonal table is implemented to confirm the effect of every QoS parameter. The volatility of pheromone dynamically employs an improved measure to speed up the convergence and to setup an optimal multicast tree which meets multiple QoS constraints. According to the scope of the search path, orthogonal table  $L_9(3^4)$  is adopted. Here 9 stands for number of searching, 4 stands for number of QoS parameters and 3 is noted as the number of levels about searching path. In simulation experiments 8 nodes are taken with constrained function of 4 dimensional vector as (D, DJ, B, C). Algorithm can quickly achieve the optimal solution and satisfy multiple QoS constraints.

Genhang Ding et al. (2012) proposed an Improved Ant Colony Algorithm (IACA). It includes multi strategies for solving QoS routing problems by changing pheromone update rule and substituting the piecewise function  $Q(t)$  for the probability constant which is chosen by ants when a route is selected. Improvements of algorithm are defined in number of stages. In stage one: set lower bound and upper bound for pheromone. In stage two: use  $Q(t) = \log(t+1)$  instead of  $Q$  based on the stage one. In stage three: use piecewise function  $q_0(t)$  instead of constant  $q_0$  chosen by ants based on the stage two. In beginning of the iteration, the value of  $Q(t)$  should be smaller so that the increment of pheromone in each route will be small to avoid too strong positive feedback. In later iterations, the value of  $Q(t)$  becomes bigger to speed up the convergence. The algorithm makes the search space as large as possible for finding optimal solution interval and also makes full use of the current available information for focusing on searching the ranges that likely to have good fitness individuals, thus to converge to the global optimal solution as soon as possible. Algorithm set (cost, delay, delay-jitter, packet-loss) for each node and set (cost, delay, delay-jitter, bandwidth) for each link. Number of ants taken as 30 and maximum number of iterations is taken as 100 for the simulation purpose. Experimental results show that the success rate of the improved ant colony algorithm in solving QoS routing problems and the ratio to obtain the optimal solution reach up to 99.81 % and 99.65 % respectively. The results are much better than those obtained by the basic ant colony algorithm.

Sun Gai-ping et al. (2010) proposed an ant colony optimization algorithm ANBRA for ad hoc network routing based on the network link and node status. In ANRBA, it uses the load accepted rate, topology variety rate and routing delay time as measurement value to select the routing paths. After establishing routing paths, use the ant colony algorithm to gather the routing paths' measurement and dynamically update the pheromone table, which dynamically distribute the network load. In NS2, 50 nodes move in the region  $1000 \times 1000 \text{ m}^2$  with varying pause time in range of 0 to 300 seconds. Node speed is taken as 10m/s with bandwidth 2 M b/s. Simulation time is taken as 400 seconds with 10 CBR traffic connections. ANBRA performs much better in packet switched rate and average delay time with varying pause time.

A. Sabari et al. (2008) proposed Ant colony based Multicast Routing (AMR) which optimizes several objectives simultaneously to solve the traffic engineering multicast problem. Algorithm calculates one more additional constraint in the cost-metrics, which is the product of average delay and the maximum depth of the multicast tree and try to minimize this combined cost metrics. Algorithm calculates the shortest path tree from root using ACO technique. With modified heuristic function to form degree bounded spanning trees, it ensures that all hosts connect to the source through a host that is closer to the root. Each node must be connected to a parent that is closer to the root than itself, that is if a's parent is b then  $dM(b, \text{root}) \leq dM(a, \text{root})$ . This helps to reduce the delay introduced by deviations from the optimal path. In NS2, 25 to 75 nodes move in the region of  $600 \times 600 \text{ m}^2$  and node's maximum speed is 10 m/s with pause time of 5 seconds. Traffic is taken as CBR and simulation time is 50 seconds. Performance metrics are packet delivery ratio (PDR), delay multiplied with depth and control overhead. Result shows that packet delivery ratio is increased while control overhead and routing overhead are reduced with varying node density.

P. Deepalakshmi et al. (2011) proposed an Ant based Multi objective on demand QoS Routing algorithm (AMQR) for MANET is highly adaptive, efficient, scalable and reduces end-to-end delay in high mobility cases. Proposed approach has phases of route exploration and route maintenance. Ant like packets are used to locally find new paths. Artificial pheromone is laid on communication links between adjacent nodes and route reply and data packets are inclined towards strong pheromone, where as next hop is chosen probabilistically. Each node running this algorithm contains three tables namely neighbour, path preference and routing. The neighbour node which has a higher path preference value will be copied to routing table for the related destination on desired. In NS2, 50 to 100 nodes move in the region of  $1500 \times 1500 \text{ m}^2$  with node mobility in the range of 10 to 80 m/s and simulation period of 900 seconds. AMQR has been compared with AODV and ANTHOCNET in terms of delay, throughput, jitter with various flow counts, node mobility and various pause times. It provides good packet delivery ratio, reduces delay and jitter but with high routing overhead.

Miae woo et al. (2008) proposed an ant-based multi-path routing algorithm with both reactive and proactive elements. Route setup and recovery phases are reactive elements. In the algorithm, pheromone heuristic control is used for stagnation. Used factors for the heuristic function are queue length and average delay at the MAC layer. A reactive backward ant can also be generated by any legitimate intermediate node, which is a unique feature in the proposed algorithm based on the conditions: 1) There should be no backward ant generated by any other previous visited node enroute to the intermediate node. 2) The routing information to the destination should be fresh enough. 3) The hop count between the source and intermediate node should be within some range values. 4) In proposed algorithm, the number of entries for a specific node in the routing table is controlled in order to reduce the overhead in the routing table. Priorities are given to the entries updated by backward ant generated from the destination and entries with fresh pheromone values. In Qualnet, 100 nodes with 20 traffic sources move in the region of  $3000 \times 1000 \text{ m}^2$  with pause time in range of 0 to 300 seconds and simulation period of 300 seconds. Performance metrics are taken as average number of



forward ant delivered, average number of backward ant delivered, end-to-end delay and packet delivery ratio with various pause times. The proposed algorithm effectively control the overhead generated by the ants, while achieving faster end-to-end delay and improved packet delivery ratio.

R. Ashokan et al. (2008) proposed Ant DSR (ADSR), a QoS dynamic source routing protocol using ant colony optimization. It takes consideration of three QoS parameters delay, jitter and energy. In DSR, mobile nodes are required to maintain route caches that contain the complete routes about which the mobile node is aware and entries are updated as new route is learnt. The mechanism was based on the forward ant (FANT) and backward ant (BANT) packets added in the route request and route reply. The proposed protocol selects a minimum delay path with the maximum residual energy at nodes. In NS2, 100 nodes move in the region of  $500 \times 500 \text{ m}^2$ , with communication range of 50 meter, node speed between 0 to 100 m/s and pause time of 0 to 500 seconds. Performance metrics are taken as end-to-end delay, energy, jitter, throughput and routing overhead with varying mobility and pause times. Result shows improvement in packet delivery ratio, end-to-end delay and residual energy while slightly high overhead than DSR.

Bibhash Roy et al. (2012) proposed algorithm which combines the idea of ant colony optimization with Optimized Link State Routing (OLSR) protocol to identify multiple stable paths between source and destination nodes. The algorithm consists of both reactive and proactive components. In a reactive path setup phase, an option of multiple paths selection can be used to build the link between the source and destination during a data session. Ant agents are used to select multiple nodes and these nodes further use ant agents to establish connection with intermediate nodes.

Salim Bitam et al. (2012) proposed MQBM, a bio-inspired protocol which is based on the bee's communication while searching their food. MQBM is considered as an on-demand, adaptive and tree-based protocol. It broadcasts its route request to a limited number of neighbours to find the multicast group. MQBM detects multiple paths between sender and receiver. They can be used to send out packets in parallel in order to optimize data transmission. End-to-end delay and the average bandwidth satisfy the QoS requirements. MQBM takes two phases: the first step aims to find one of the group members using unicast and multipath routing and in second step, packets are disseminated to other members through the head of the group. In NS2, 50 nodes move in the region of  $1500 \times 300 \text{ m}^2$  with simulation period of 900 seconds. Number of members in multicast group varies between 10 to 50. Result shows improvement in packet delivery ratio and bandwidth.

S. Samadi et al. (2012) proposed Adaptive Multipath Ant Routing algorithm (AMAR) which is hybrid multipath algorithm, designed along the principles of ACO routing and multipath routing. It consists of reactive path setup, stochastic data routing, proactive path maintenance and exploration and link failures. In Qualnet, 100 nodes move in the region of  $2400 \times 800 \text{ m}^2$  with node speed between 0 to 30 m/s. Pause time is taken in the range of 0 to 500 m/s and simulation period is of 900 seconds. Result shows improvement in packet delivery ratio and end-to-end delay.

Se-Young Lee et al. (2005) proposed Ad hoc Network Multicasting with Ant System (ANMAS) which is based on ant colony optimization system. Algorithm in particular utilizes the indirect communication method of the ants via "pheromone" to effectively obtain dynamic topology and to generate multicasting paths. It adopts the well-known CBT (Core Based Tree) into the ANMAS framework with proper modifications to make "tolerable" multicasting group in the MANET environment. The pheromone of each node contains its distance to the core and the measure of its "safety" on the path to the core. The newest pheromone information is used so that multicasting routes are adaptively constructed depending on dynamic topology changes. 50 nodes and 200 nodes are taken for two simulations in an area of  $1000 \times 1000 \text{ m}^2$  with bandwidth of 2 Mbps. Node velocity is taken between 0 to 20 m/s and

simulation time is taken as 330 seconds. ANMAS provides a good packet delivery ratio with a small increase in the number of control packets, which do not depend proportionally on the number of sources. ANMAS will be highly effective for the domains that need multiple-to-multiple node multicasting.

Javad Barbin et al. (2012) proposed ACO based QoS routing algorithm. Algorithm is multipath routing and has two phases namely route discovery phase and route maintenance phase. Proposed algorithm starts from the destination node and the data packet is sent along backward path. In VC++ 6.0, 50 nodes in region of  $1500 \times 300 \text{ m}^2$  are defined with simulation period of 900 seconds. Number of packet delivered and overhead routing is identified with varying simulation time in range of 0 to 900 seconds. Multi Path Ant Colony (MPAC) algorithm is highly adaptive, efficient, scalable and mainly reduces end-to-end delay in high mobility cases.

P. Deepalakshmi et al. (2011) proposed source initiated mesh and Soft-state based QoS probabilistic Multicast routing Protocol (SQMP) for MANET based on the ant foraging behaviour. Mesh creation of proposed algorithm involves two phases namely query phase and reply phase. Query phase is invoked by the multicast source node to initiate the mesh route discovery process. The reply phase is initiated by the multicast group receivers to multicast sources through different QoS satisfied paths. Multiple paths have been found with first rate path preference probability. The data is sent over the paths with higher path preference probability which can satisfy the bandwidth requirement and delay of applications. In NS2, 50 nodes move in the region of  $1000 \times 1000 \text{ m}^2$  with speed of 0 to 20 m/s for a simulation period of 300 seconds. The proposed algorithm has been compared with ODMRP in terms of PDR, total bytes transmitted per data byte received with respect to mobility.

Sungwook Kim et al. (2012) proposed a multipath QoS aware routing protocol based on ACO. To enhance network reliability, routing packets are adaptively distributed through the established multiple paths. This multipath routing mechanism can ease out the heavy traffic load in a specific link to ensure the balanced network resource consumption. For efficient network management, control decisions in the proposed algorithm are made dynamically by using real-time measurements. In NS2, 100 nodes move in the region of  $500 \times 500 \text{ m}^2$  with three different types of CBR traffic taken as 128 kbps, 256 kbps and 512 kbps. Node remaining-energy ratio, packet delivery ratio, packet loss probability and delay commitment ratio are measured with respect to offered load (packet generation rate).

Debasmita Mukherjee et al. (2012) proposed ACO variants for solving MANET routing problems. Variations are related to the selection of next node to visit which depends on the number of adjacent nodes to the current node and modification of the pheromone deposited formula on the basis of transmission time. In some variants, a tabu list (last visited n number of nodes) has been incorporated to enhance the performance remarkably. In NHS1, no node is allowed to select an already visited node to avoid cycle formation. NHS2 allows selecting an already visited node provided that it is not present in the tabu list. In modified versions, number of nodes has been incorporated in the path probability formula for selecting the next node. Another modification is inclusion of the transmission time of the packets in the pheromone deposit formula to make it more suitable for realistic situation. With existing variants of ACO namely, Ant System (AS), Max-Min Ant System (MMAS) and Ant Colony System (ACS), applying two different next node selection criteria six variants of ACO are defined, that are AS-NHS1, AS-NHS2, MMAS-NHS1, MMAS-NHS2, ACS-NHS1 and ACS-NHS2. In NS2, 16 to 100 nodes move in the region of  $1000 \times 1000 \text{ m}^2$  with 1 to 20 m/s node mobility. CBR traffic is considered for simulation period of 200 seconds. Performance metrics are considered as packet drop rate and throughput for network. ACS-NHS1 outperforms others in maximizing throughput and MMAS-NHS2 is the best in minimizing packet drop rate. Comparative behaviour of the modified variants remains same as before but absolute performance is better.

## Performance Evaluation:

In this section various ant colony based unicast and multicast routing protocols, studied in previous section are compared with respect to different attributes, performance metrics and network parameters.

Protocol attributes can be defined as routing scheme, path type, routing structure, QoS constraints and performance metrics. Simulation area, number of nodes, node speed and simulators are defined under network parameters. Table I defines summary attributes of ant colony based algorithms.

TABLE I SIMULATION PARAMETERS

Algorithm Protocol	Routing Scheme	Path Type	Routing Structure	Adherence of Multicast	QoS Constraints	Performance Metrics	Network Parameters			
							Area (m <sup>2</sup> )	Nodes	Speed (m/s)	Simulator
S.Mangai et al. [2] DCOMP	R	ME	F	Yes		PDR, Control overhead	1000*1000	50	0-20	NS 2
Kewen Li et al. [4]	R	M	F	Yes	D,DJ,B,PL	Cost, Jitter		8		
Wenyong Liu et al.[5]	H	S	F	Yes	D,B,C	PDR, E2E delay	1000*1000	50	0-10	
Bencan Gong et al. [6]	R	S	F	Yes	D,DJ,B,PL	Cost, Delay, Jitter		100		
A. Sabari et al. [7] AAMRP	R	S	H	Yes		PDR, E2E delay, Control Overhead, Routing load	600*600	25-50-75-100	10	NS 2
Bencan Gong et al. [8]	R	S	F	Yes	D,DJ,B,PL	Cost, Jitter		100		
Kewen Li et al. [9]	R	S	F	Yes	D,DJ,B,C	Delay		8		
Genhang Ding et al. [10] IACA	R	S	F	No	D,DJ,B,C, PL	Success rate, % of optimal solution found		30		
Sun Gai-ping et al. [11] ANBRA	R	S	F	No	D	PDR, E2E delay,	1000*1000	50	10	NS 2
A. Sabari et al. [12] AMR	R	S	F	Yes	C,D	PDR,Control overhead, routing overhead	600*600	25-75	10	NS 2
P. Deepal akshami et al. [13] AMQR	R	M	F	No	D,J,B, hop count	PDR, E2E delay, jitter, routing overhead	1500*1500	50-100	10-80	NS 2
Miae Woo et al.[14]	R+P	M	F	No		E2E delay, PDR	3000*1000	100		Qualnet
R. Ashokan et al.[15] ADSR	R	S	F	No	D,J, Energy	Jitter, E2E delay, energy, throughput, routing overhead	500*500	100	0-10	NS2
Bibhas Roy et al.[16]	H	M	F	No						
Salim Bitan et al. [17] MQBM	R	M	F	yes		PDR, bandwidth	1500*300	50		NS2
S. Samadi et al. [18] AMAR	H	M	F	No		PDR,E2E delay	2400*800	100	0-30	Qualnet
Se-yong Lee et al. [19]	R	ME	F	Yes		PDR, Control overhead	1000*1000	50-200	0-20	
Javad Barbin et al.[20] MPAC	R	M	F	No		E2E delay ,PDR, Routing overhead	1500*300	50	10	VC++
P.	R	ME	F	yes		PDR	1000*100	50	0	NS 2

Deepalakshmi et al.[21] SQMP							0		20	
Sungwook Kim et al.[22]	R	M	F	yes		PDR,PLR,E2E delay	500*500	100		NS 2
Debasmita Mukherjee et al.[23]	R	S	F	No		Packet drop rate, throughput	1000*100 0	16 100	1 20	NS 2

Routing Scheme (R: Reactive, P: Proactive, H: Hybrid), Path Type (M: Multipath, ME: Mesh based, S:Singlepath), Routing Structure (F: Flat, H: Hierarchical), QoS Constraints (B: Bandwidth, D: Delay, DJ: Delay Jitter, PL: Packet Loss, C: Cost), Simulator (NS2: Network Simulator, VC++: Visual C++)

### Conclusion:

In this paper, various ant based routing algorithms are reviewed and compared in terms of protocol attributes, performance matrices and network parameters. Ant colony based machine learning approach provides more promising result compared to conventional routing protocols. Ant Colony approach is widely used to provide QoS parameters for unicast and multicast routing algorithms. Techniques are more robust as well as computation time is moderate or low. Complexity of algorithm is high compared to other techniques, but even with high complexity, processing time is fast. Many of them do not consider the multi-constraint problems of QoS routing in MANET. Even though some of them deal with multi-constraint QoS parameters, they are restrictive with respect to scalability. Also, they do not explore service differentiation using service classes for QoS provisioning. To get an effective and efficient ant based routing protocol in MANETs, it is required to consider real scenarios and environment constraints during simulation.

### References:

- Z. Ali and W. Shahzad, "Analysis of Routing Protocols in AD HOC and Sensor Wireless Networks Based on Swarm Intelligence", International Journal of network and Communications, Vol.3, No. 1, p.p. 1-11, 2013.
- S. Mangai, A. Tamilarasi and C. Venkatesh, "Dynamic Core Multicast Routing Protocol implementation using ANT Colony Optimization in Adhoc Wireless Networks", IEEE International Conference on Computing, Communication and Networking, p.p. 1-5, 2008.
- M. Dorigo, M. Birattari and T. Stützle, "Ant Colony Optimization: artificial ants as a computational intelligence technique", IEEE Computational Intelligence, Vol 1, No. 4, p.p. 28-39, 2006.
- K. Li and J. Tian, "Application of Improved Ant Colony Algorithm to the QoS Multicast Routing", IEEE International Workshop on Education Technology and Training and International Workshop on Geoscience and Remote Sensing, p.p. 780-784, 2008.
- W. Liu, K. Li and J. Tian, "The Application of Ant Colony Algorithm on Mobile Multicast Routing", International Conference on Wireless Communications, Networking and Mobile Computing (WiCom), p.p. 1-4, 2009.
- B. Gong, L. Li and X. Wang and T. Jiang, "A Novel QoS Multicast Routing Algorithm Based on Ant Algorithm", International Conference on Wireless Communications, Networking and Mobile Computing (WiCom), pp. 2025-2028, 2007.
- A. Sabari and K. Duraiswamy, "Ant Based Adaptive Multicast Routing Protocol (AAMRP) for Mobile Ad Hoc Networks", International Journal of Computer Science and Information Security (IJCSIS), Vol. 6, No. 2, p.p. 199-207, 2009.
- B. Gong, L. Li and X. Wang, "Multicast Routing Based on Ant Algorithm with Multiple Constraints", International Conference on Wireless Communications, Networking and Mobile Computing (WiCom), pp. 1945-1948, 2007.

- K. Li and J. Tian, "A QoS Mobile Multicast Routing Algorithm Based Ant Colony Algorithm", IEEE Pacific-Asia Workshop on Computational Intelligence and Industrial Application, pp. 88-92, 2008.
- G. Ding, L. Shi, X. Wu and Y. Zhang, "Improved Ant Colony Algorithm with Multi-Strategies for QoS Routing Problems", IEEE 8<sup>th</sup> International Conference on Natural Computation, p.p. 767-771, 2012.
- S.G. Ping, G.H. Wen, W. Dezhi and J. Hua, "A Dynamic Ant Colony Optimization Algorithm for the Ad Hoc Network Routing", IEEE Fourth International Conference on Genetic and Evolutionary Computing, p.p. 358-361, 2010.
- A. Sabari and K. Duraiswamy, "Ant Based Multicast Routing Algorithm with Multiple Constraints for Mobile Adhoc Networks", IEEE International Conference on Security Technology, pp. 35-40, 2008.
- P. Deepalakshmi and S. Radhakrishnan, "An ant colony-based multi objective quality of service routing for mobile ad hoc networks", EURASIP Journal on Wireless Communications and Networking, Vol. 1, No. 153, pp. 1-12, 2011.
- M. Woo, N.H. Dung and W.J. Roh, "An Efficient Ant-based Routing Algorithm for MANETs", Proc. Of 10th Intl Conf on Advanced Communication Technology (ICACT), Vol.2, pp. 933-937, 2008.
- R. Asokan, A.M. Natarajan and C. Venkatesh, "Ant Based Dynamic Source Routing Protocol to Support Multiple Quality of Service (QoS) Metrics in Mobile Ad Hoc Networks", International Journal of Computer Science and Security, Vol. 2, No. 3, pp. 48-56, 2008.
- B. Roy, S. Banik, P. Dey, S. Sanyal and N. Chaki, "Ant Colony based Routing for Mobile Ad-Hoc Networks towards Improved Quality of Services", Journal of Emerging Trends in Computing and Information Sciences, Vol. 3, No. 1, pp. 10-14, 2012.
- S. Bitam and A. Mellouk, "MQBM: an autonomic QoS multicast routing protocol for mobile ad hoc networks", IEEE International Conference on Communications (ICC), pp. 5488-5492, 2012.
- S. Samadi and H. Beigy, "An Adaptive Multipath Ant Routing algorithm for Mobile Ad Hoc Networks", International Journal of Computer and Electrical Engineering, Vol. 4, No. 2, pp. 175-180, 2012.
- S. Lee and H.S. Chang, "An Ant System Based Multicasting in Mobile Ad Hoc Network", IEEE Congress on Evolutionary Computation, Vol. 2, pp. 1583-1588, 2005.
- J. P. Barbin, M. Taghipoor and V. Hosseini, "A Novel Algorithm for Manets using Ant Colony", IJCSI International Journal of Computer Science Issues, Vol. 9, No. 1, pp. 109-113, 2012.
- P. Deepalakshmi and S. Radhakrishnan, "Source-Initiated QoS Multicasting Scheme For MANETS using ACO", IEEE International Conference on Process Automation, Control and Computing (PACC), pp. 1-4, 2011.
- S. Kim, "An Ant-based Multipath Routing Algorithm for QoS Aware Mobile Ad-hoc Networks", Springer, Wireless Pers Commun, Vol. 66, pp. 739-749, 2012.
- D. Mukherjee and S. Acharyya, "ACO Variants in Solving Mobile Ad Hoc Network Routing", IEEE Third International Conference on Emerging Applications of Information Technology (EAIT), pp. 366-371, 2012.

# ADDRESSING COMMUNITY BASED PROBLEMS: EXPLORING THE ROLE OF CBO THROUGH PARTICIPATORY APPROACH

*Sadya Islam*

*Antora M. Haque*

*Mohammad T. H. Shubho*

*Dr. Ishrat Islam*

*Farzana Khatun*

*Dipita Hossain*

Bangladesh University of Engineering and Technology

---

## Abstract

Urban and rural communities in a country are sometimes confronted with many problems which are well understood by the community residents itself. A Community Based Organization (CBO), in this regard, can play the major role to solve these problems by self-initiative participatory approach. Community Based Organization (CBO) is such a non-profit institute which operates within a community to provide the local services and is usually run by the local people of that community. Rather depending on local/central government, the community itself can solve certain problems with the assistance of local people and CBOs. In such backdrop, this research was intended to unfold the role of CBO in improving the urban community through Participatory Reflection and Action (PRA) method. The study is based on an urban CBO of *Lalbag Thana* in South Dhaka, Bangladesh. This research was intended to identify the major problems, their causes and effects on the study area and possible solutions of those problems through active participation of both CBO and its people. Several PRA tools were employed to obtain the objectives. Sewerage and drainage problem, poor water quality and water supply, narrow and poor condition of access roads etc. were the major problems. Effective solutions came forth from the locality for solving those problems such as: provision of water extraction pump and reservoir, drain cover and street dustbins and enforcement of building bye-laws etc. Whilst having the potential, the CBO was found inadequate to implement the solutions due to lack of resource mobilization. However, success of this research is a clear indication that community improvement is possible through mobilization of CBO and ensuring public participation.

---

**Keywords:** PRA, CBO, community participation, community improvement

## 1. Introduction:

A community can be defined as a group of people who shares an interest, a neighborhood or a common set of circumstances irrespective of the acknowledgement of the membership (Smithies and Webster, 1998). Development of these communities ensures a developed urban or rural area as a whole. However, this development cannot be sustainable unless people's participation is made central to the development process (Kumar, 2002). Economic Commission of Latin America (1973) considers participation as people's voluntary contribution in the public programs and their complete exclusion from the decision making process. Community Based Organization (CBO) is a non government, non profit organization that is driven by the active participation of community residents in all aspects of its existence

(NCBON, 2004). It can be registered or non registered and its functions are aimed to develop the community area by solving its planning related problems.

Usually national and local government bodies are responsible for an areas maintenance and development. Due to ponderous procedure of bureaucracy, belated aid from government makes the daily life of community people miserable. The cities of Bangladesh has the similar scenarion. The local community has to depend upon the local/central government authority for solving any kind of problems of the community. But many of these problems (like: insufficient water supply, poor road condition etc) can be solved by the local people themselves which does not require any expert's advice. Rather very effective solutions can be elicited from the community people themselves to solve the endemic problems. To institutionalise their participation, a CBO can be set up. Different studies, both in home and abroad, have shown the success of participatory approach in solving local problems. It was found that, PRA techniques have strengthened low income urban communities in UK, Sri Lanka, India and South Africa (McCracken and Narayan, 1998) for solving community problems. In Bangladesh, PRA tool was applied to find out the causes of the extinction of *Jamdani* Weavers community in *Kajipur* (Jamdani Weavers' Community, 2008). These paradigms concretize the fact that, effective sharing of participant's knowledge and experience can be achieved by applying various Participatory Reflection and Action (PRA) tools in the CBO. If all the CBOs try to manage their local planning related problems as such, then it will improve the national condition as a whole.

This paper is based on addressing the local planning related problems through community participation by applying various PRA tools on a local CBO of Dhaka city called *Lalbag* Society. The role of this CBO has been explored to understand the capacity of participatory approaches to serve and improve a community.

## 2. Study Area:

Dhaka, the capital city of Bangladesh, is going through a rapid development (Hussain, 2008; Enam and Choudhury, n.d.; Ahmed et al. 2009). Southern part of Dhaka has developed in an unplanned way (Mridha, 2008). Such slapdash developments have hindered the subsequent planned development process. *Lalbag* Society is a CBO located at the southern part of Dhaka city. At present there are 92 wards in Dhaka city (Haque *et al.*, 2013) and study area belongs to ward number 26. The study area (Figure 1) is about 8400 sq.m which accommodates 1500 people. Population density is 722 persons/acre. There are about 85 to 90 households in the study area. Most of the high and middle income people are businessmen and service holders respectively. There are a few low income people who are street hawkers, mechanics, tailors and garments workers. Since 1968 the establishment of *Lalbag* fort or Aurangabad fort influenced the surrounding of *Lalbag* to grow as an urban area. Consequently many people started to live here making it a densely populated area. During reign of the British East India Company *Lalbag* was modernized under the British rule. Several educational institutes, public works and township were developed. Many hindu and biahri people lived in its surrounding who left the place after the end of the war in 1971. (Banglapedia, n.d.)

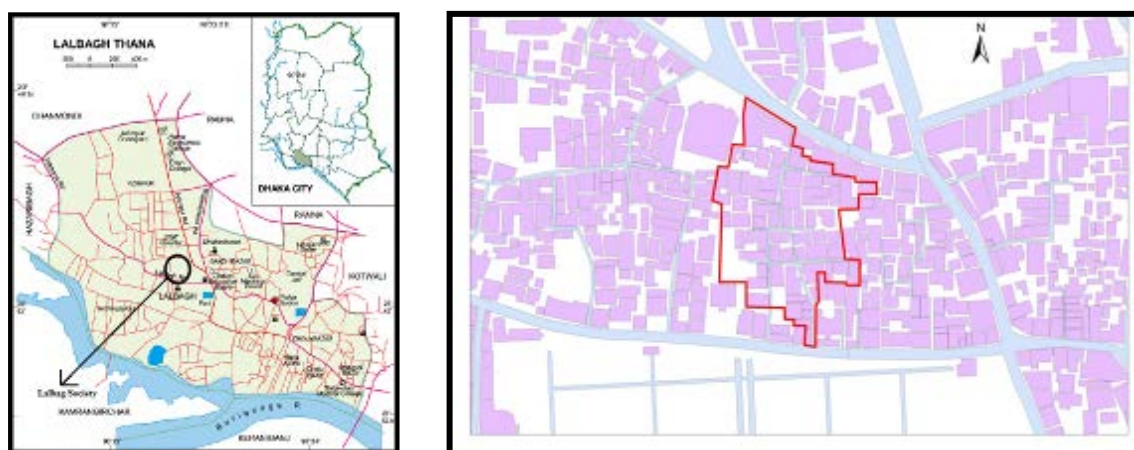

Figure 1: (a) *Lalbagh thana* within Dhaka city; (b) Study area within *Lalbagh thana*

Year	Event	Remarks
1678	Birth of Lalbagh area as a residential area	Influenced by construction of Lalbagh Kella.
1940	Presence of Police Baroque inside Lalbagh area	
1947	Pakistan army also used this Police Baroque	Attracted Bihari people to live in this community.
1947	Up to this period every house had 2 wells for water.	1 well served drinking purpose and 1 well served other purposes.
1947	Forest of almost 2000-3000 trees.	Many fox and monkeys lived in this forest. Sometimes the monkeys came and took away people's clothes.
1948	Beginning of construction of Pucca buildings	<ul style="list-style-type: none"> <li>• Introduction of Pipe water supply to the pucca households.</li> <li>• Introduction of Electricity supply to some of the houses.</li> </ul>
1948	Introduction of outdoor water supply	1 water tap was established for public use.
1962-1965	Westernized School, Nobokumar School and Azimpur School were established.	People of this community send their children to these local schools.
1968	Non electric lamps or lanterns were used to lit the roads	These lights were manually operated.
1948-1971	Local people used to do shopping from Chok Moulavibazar.	After establishment of Kellar Mor hazaar Chok Moulavibazar is less frequently used by the community.

Figure 2: Time Line showing the history of *Lalbagh Society*

## 2.1 Historical Background of *Lalbagh Society*

Since the birth of *Lalbagh* residential area, it has gone through many physical changes and encountered planning related problems. Local people came up with the idea of setting up a CBO to deal with the problems after the liberation war of 1971.

A time line has been prepared to investigate about the action of this CBO which is shown by Figure 2. An elderly person of the local area was interviewed to get the historical background and useful information regarding the activities of CBO. According to him, after the liberation war of 1971, an organization named '*Torun Shangho* (Youth Club)' was set up. Although it was a sports club, it used to deal with community problems also. In 1991, first election of '*Torun Shangho*' was held and it officially started to function as an established organization. Since then, the chairperson along with the members used to call in a meeting and took decisions regarding community problems whenever they encountered any. In 1992, this CBO installed two gates to increase the safety of the community because at that period



the incident of robbery had increased in that locality. There have been many low income people in the locality who were unable to afford piped water supply in their household. To provide free water supply to these people two cost free outdoor water taps were established in 1997 by the initiatives of this CBO. In 2011, ‘*Torun Shongho*’ initiated the collection of garbage from the locality in order to keep the environment clean and hygienic. In 2012, the name of ‘*Torun Shongho*’ was changed to ‘*Lalbag Society*’. Since then this CBO has become the official organization to solve various planning related problems of this locality. On March 2012 it installed street light at some important sections of the area to add to the safety factor of the area.

**2.2 Physical and social features of the area:**

Physical characteristics of the study area were comprehended by performing ‘Transect Walk’. Depending on the shape and size, two transect paths were chosen to traverse the study area to observe the topography, buildings characteristics, roads and utility facilities. Those Transact paths were at North-South direction (360 feet) and East-West direction (213 feet). Along these directions the sections and elevations are shown in Figure 3.

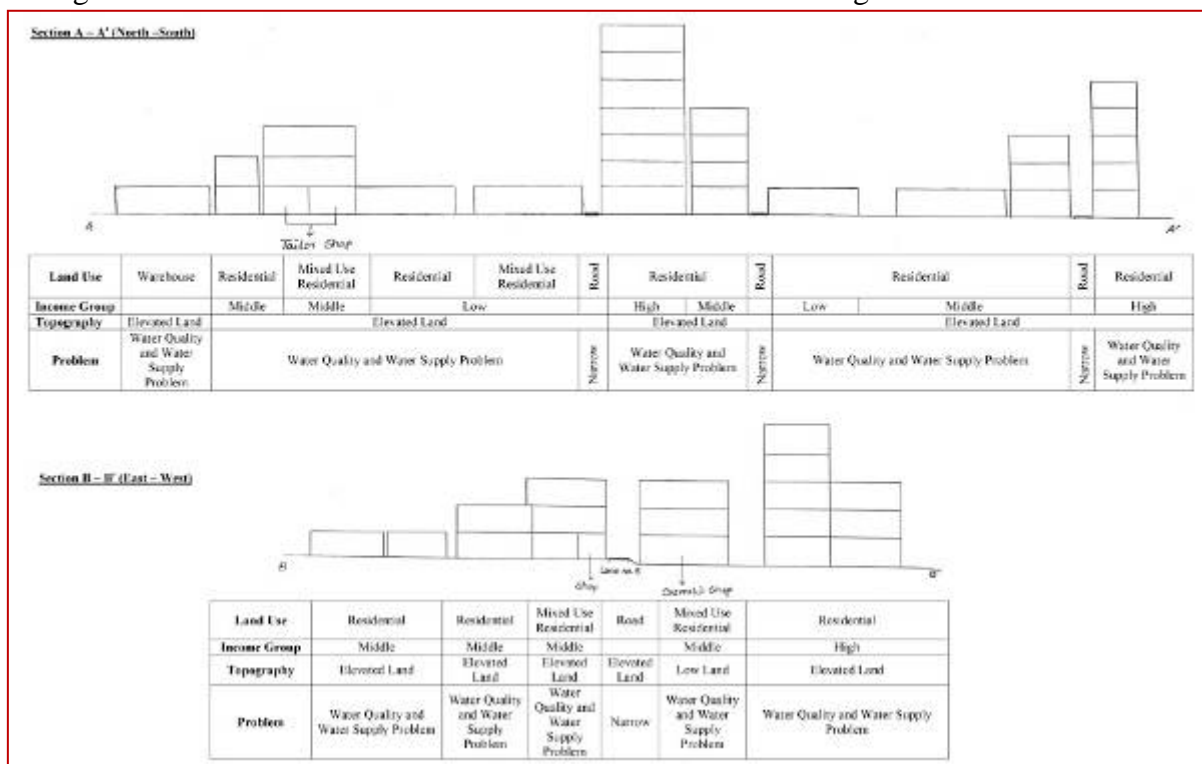

**Figure 3:** Section, elevation and other information along Transect paths

Social and physical resources of the study area were also examined as manifested by Figure 4. The study area can be characterized as a mixed use residential area. Most of the buildings’ ground floor is used as grocery shops, corner shops, salons, tailor shops, cosmetic shops, and warehouses where the upper floors are used for residential purposes. Most of the buildings range from 3 to 6 stories. Each building was categorized under three broad classes

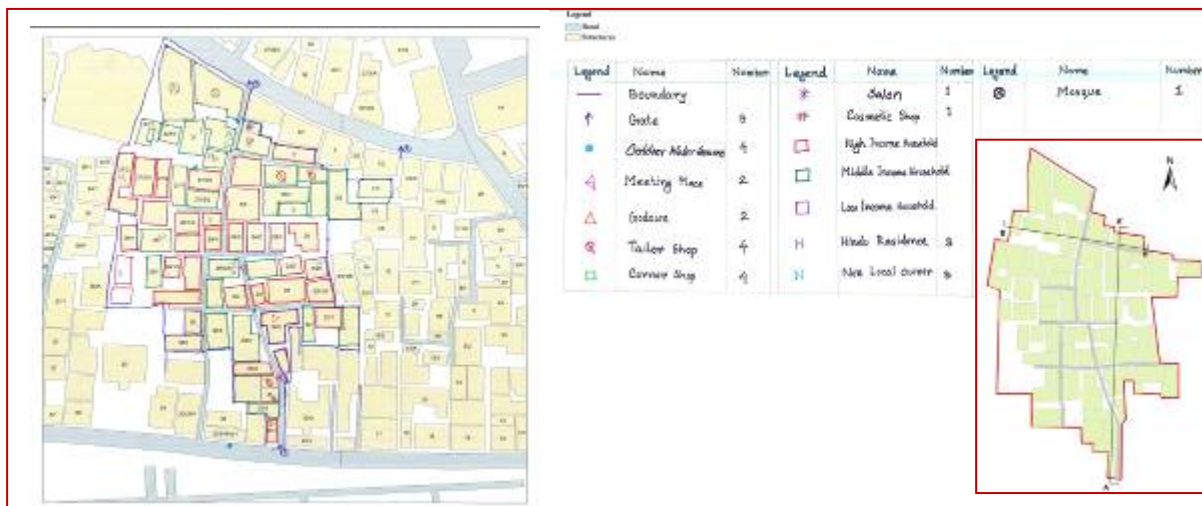

**Figure 4:** Social and resource map of the study area such as- high income households, low income households, middle income households. There is only one mosque in the entire study area. It serves also as a community place where people socialize with each other and also it is the meeting place of the *Lalbag* CBO. There are other two places where meeting of *Lalbag* Society is held. Another important resource of this area is the office of ward commissioner which is not inside the study area, but it is located just beside the area along the Ajampur road adjacent to the Mosque.

**3. Methodology:**

Every locality has some major and secondary problems which should be carefully identified and prioritized through participation of local people. To address the major problems of *Lalbag* society various participatory tools such as pair-wise ranking method, cause-effect diagram, venn-diagram, seasonal and spatial diagram were applied. To determine the possible solutions to the identified problems Focus Group Discussion (FGD) and Key Informant Interview (KII) were carried out. First of all, a group was formed including six to eight persons from the community. The purpose of every tool was explained to the people. They were also informed about the process of preparing the maps or any diagrams. Then they were asked to depict the major problems of the community and to find the respective solutions to those problems. Finally, to discover local people’s perception about their dream society, a Dream Map was prepared based on their suggestions following the same method.

**4. Identified problems and their effects on the locality:**

From the pair-wise ranking procedure, five problems were identified from which three top problems were further analyzed. Drainage and sewerage was the top priority, second problem was water supply and quality problem and the third one was narrow and poor condition of access roads (Table 1).

**Table 1:** Output from the pair-wise ranking of problems in *Lalbag* Society

Problem	Cultural Degeneration(C)	Water Quality and Water Supply (W)	Lack of Security (S)	Sewerage and Drainage (S <sub>w</sub> )	Narrow Road and Poor Road Condition (N)	Frequency	Rank
Cultural Degeneration(C)	X	W	C	S <sub>w</sub>	N	1	4
Water Quality and Water Supply(W)	X	X	W	S <sub>w</sub>	W	3	2
Lack of Security(S)	X	X	X	S <sub>w</sub>	N	0	5
Sewerage and Drainage(S <sub>w</sub> )	X	X	X	X	S <sub>w</sub>	4	1
Narrow Road and Poor Road Condition (N)	X	X	X	X	X	2	3

### 4.1 Sewerage and drainage problem:

In order to have an understanding over the spatial and seasonal extent of the problems, spatial and seasonal diagram was drawn respectively. For each problem, different indicators were used to depict the true picture.

Month	January	February	March	April	May	June	July	August	September	October	November	December
Indicator												
Direction of Water			☰☰☰	☰☰☰	☰☰☰	☰☰☰	☰☰☰	☰☰☰	☰☰☰	☰☰☰	☰☰☰	
Duration			⌚	⌚	⌚	⌚⌚	⌚⌚	⌚⌚	⌚	⌚		
Mosquito and Flies	🦟🦟	🦟🦟	🦟🦟	🦟🦟	🦟	🦟🦟	🦟🦟	🦟🦟	🦟	🦟🦟	🦟🦟	🦟🦟
Discomfort of Movement			🚶	🚶🚶	🚶🚶	🚶🚶	🚶🚶	🚶🚶	🚶🚶	🚶	🚶	

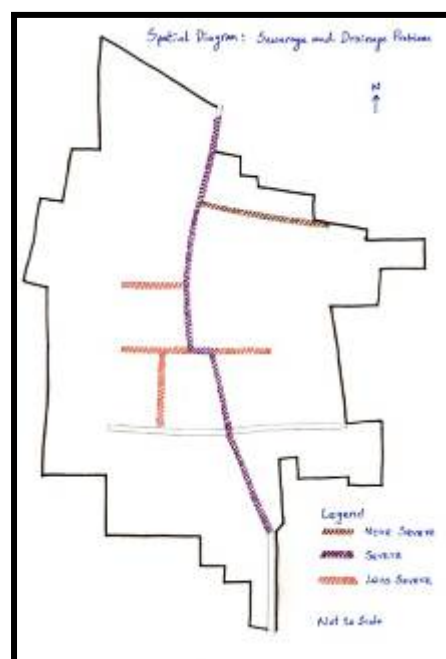

**Figure 6:** Spatial Diagram of sewerage and drainage problem of Lalbag Society

Figure 5 shows that, sewerage and drainage problem of *Lalbag* society varies in different months in case of different indicators like overflow of water, duration, mosquito and flies and discomfort of movement. Mainly drain water overflows during the rainy season and stays for a long time (Figure 6). Consequently overflowed water creates discomfort in movement and increase the disturbance of mosquitoes and flies

Cause-effect diagram (Figure 7) shows that the old sewer and drainage lines, constructed long years ago, have failed to address the growing needs of the locality. Besides, the sewerage lines which were originally earthen are now mostly broken. Consequently, the sweres of the houses have been connected to the open drain lines. In addition, local people throw the wastes in the open drain due to lack of concern. Overflow of these drains makes movement difficult inside the society and thereby causes odor and air pollution. .

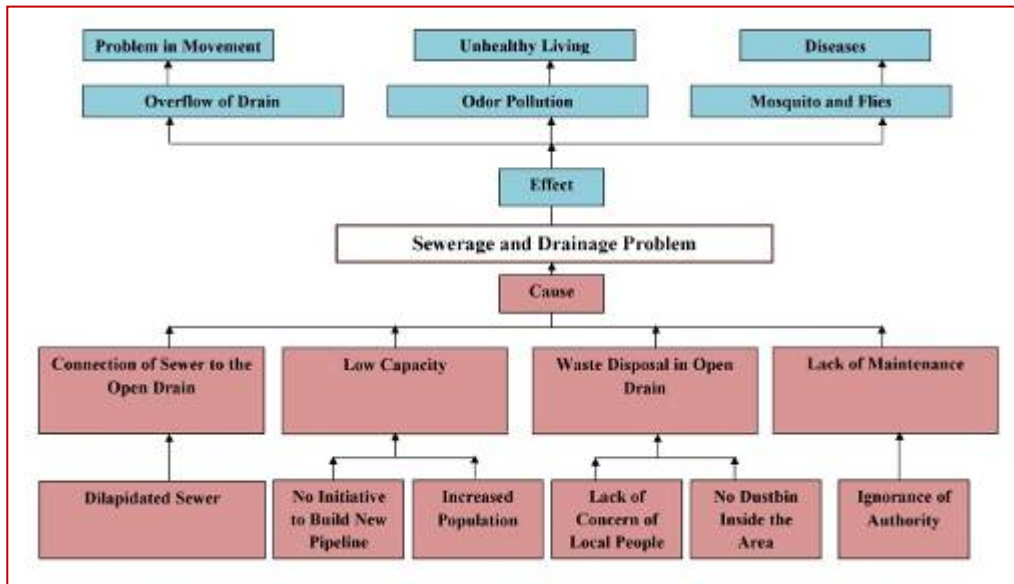

Figure 7: Cause effect relationship of sewerage and drainage problem

Besides, open drain and sewerage is the breeding ground of mosquitoes and flies which give rise to diseases like Malaria, Dengue etc. Lastly, no initiative has been taken to upgrade the sewer or drainage lines due to lack of authority’s concern.

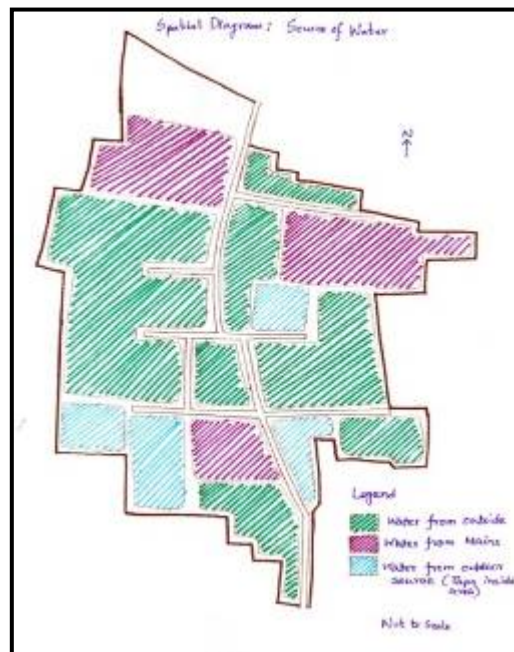

Figure 8: Spatial Diagram of source of water of Lalbag Society

**4.2 Problems with Water Quality and Water Supply:**

The second severe problem of the society is scarcity of pure drinking and usable water together with intermittent water supply. Participants informed that the major pipelines around the area that supplies water from the Saidabad Water Treatment Plant (SWTP) are in a dilapidated condition. They have got many leakages through which various suspended solids, dirt and germs enter into the pipelines and pollute the water. This polluted water has very bad taste and odor. The outdoor water sources have the same problem as well. In rainy season flood water gets mixed with the supply water and make the situation worse. At this time people bring water from outside as the taste of water becomes unbearable. Figure 8 shows the distribution of households according to the source of water supply. In addition, various water borne diseases like diarrhoea, dysentery etc and dengue breaks out due to lack of pure

drinking water in the locality. This condition is less severe in pre and post rainy season (Figure 9(a) ). To deal with this problem, people who can afford, have started using water purifier or filter in the house. Those who cannot afford to buy filter, drink boiled water which increases their gas bill (Figure 10).

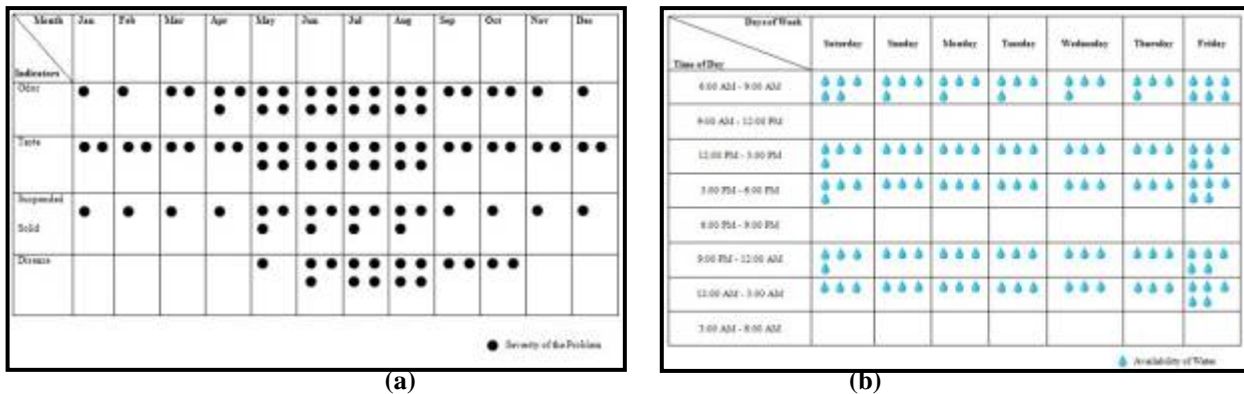

Figure 9: Seasonal Diagram (a) Water Quality Problem ;(b) Water Supply Problem

As the water supply is intermittent it also hampers the daily activity. the weekly diagram (Figure 9(b)) of water supply problem, have to of necessityThe weekly diagram of water supply problem of *Lalbag* community has been manifested by Figure 7(d). According to local people water is not available at three times of the whole day such as from 9:00 AM in the morning to 12:00 PM at noon, from 6:00 PM in the evening to 9:00 PM at night and from 3:00 AM to 6:00 AM. Therefore, local people store water to use it at the time when water is not available. Water is used at almost the same rate all over the week except on Friday and Saturday. As Friday and Saturday are holidays in Bangladesh and hence the working people usually stay home all day long which results in comparatively more usage of water.

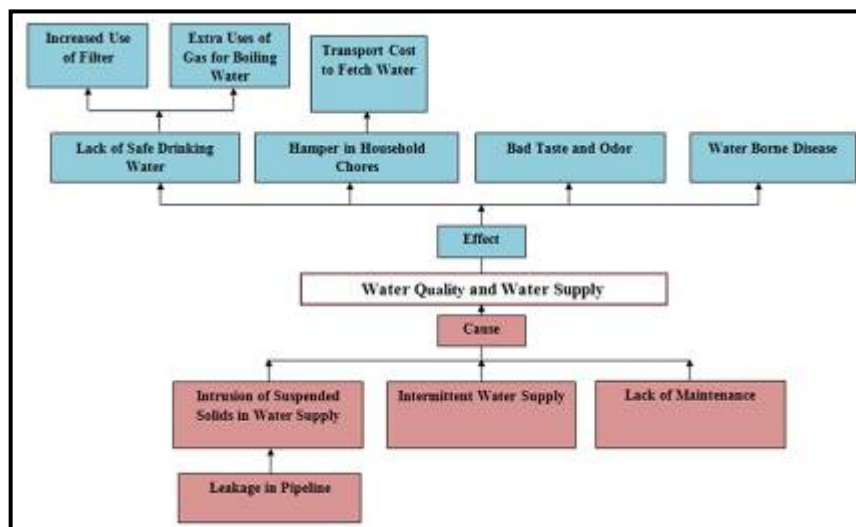
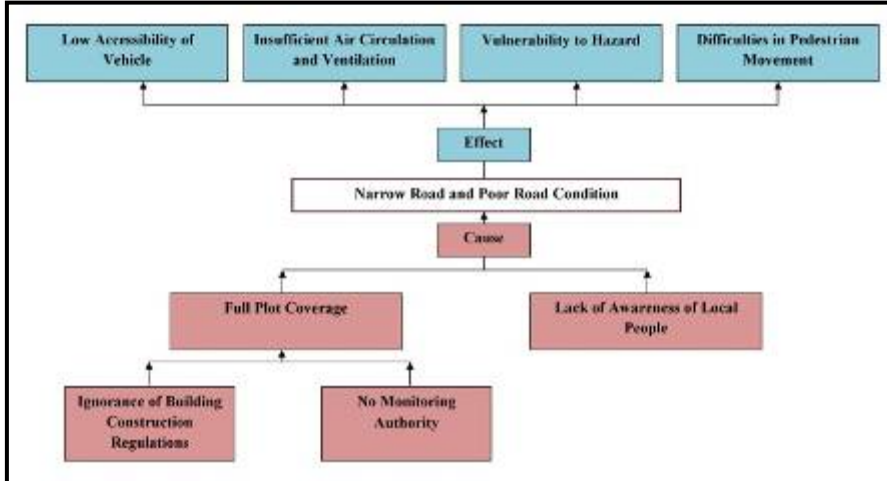

Figure 10: Cause effect relationship of Water Quality and Water Supply problem

### 4.3 Narrow and poor condition of access road:

Narrow and Poor Condition of the access road is the third major problem of *Lalbag* Society. Except only one road, which is 8’ wide, other roads inside *Lalbag* society are 5’ to 5.5’ wide. The main reason behind this scenario is local people’s ignorance of building construction regulation (Figure 11). Due to absence of any kind of monitoring authority, local people build their houses by utilizing every single inch of the plot and by not following the setback rules at all. Consequently, the roads became narrow. No vehicle, except motorcycle and bicycle, can pass through the roads. Lack of open spaces and trees inside the area, left people with no choices but to live a suffocating life. the congested buildings, narrow roads

and absence of open space make this locality extremely vulnerable to some hazards like earthquakes, fire incidents etc.



**Figure 11:** Cause effect relationship of Narrow and poor condition of access road

During rainy season, overflow of the drainages along with this narrowness characteristics of the access roads, makes it near to impossible for pedestrians to walk on the roads. The roads that are in more severe condition are the ones where the garbage stays for longer and deeper in height (Figure 12). In the less severe section of the access road the water stays during heavy rain and goes away within half an hour. The waste generation is relatively low from January to the end of April (Figure 13). Moderate amount of waste is disposed on the road in winter season. Reason behind this variation is the ignorance of authority regarding waste disposal works.

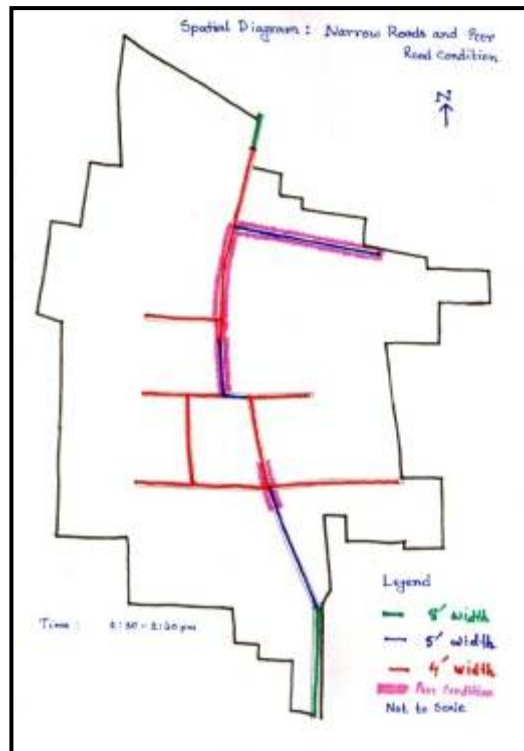

**Figure 12:** Spatial Diagram of narrow and poor condition of access road of Lalbag Society

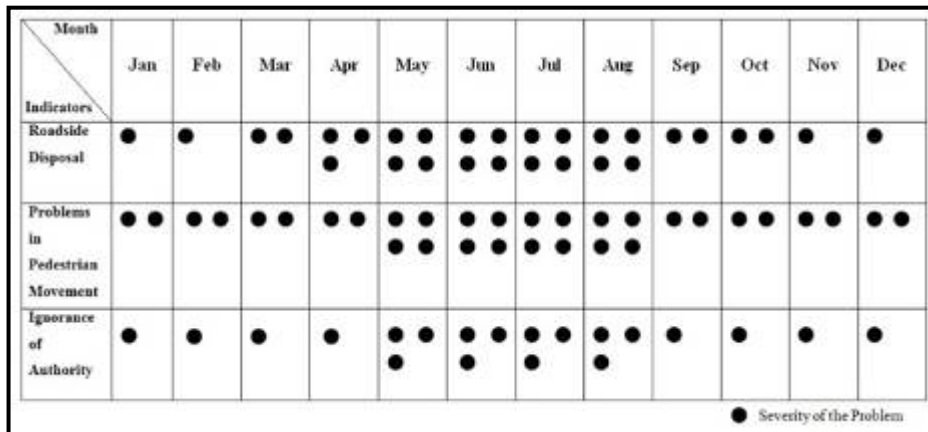

Figure 13: Seasonal Diagram of narrow and poor condition of access road problem

**5. Suggested Solutions to Address Problems:**

People of *Lalbag* society’s perception about the local area’s problems and suggestions are important as they are the one who are facing these problems every day. Before hitting upon the solutions directly, SWOT analysis was developed to assist the *Lalbag* community in building awareness about their internal strengths and external opportunities that may help in finding out the solution to the major problems. Presence of the CBO is a potential strength to the community as the CBO can take initiatives to solve the problems by themselves. Even it is likely that they will get assistance from the Word office because Secretary of word commissioner lives inside the community. Moreover his office is also placed near the community.

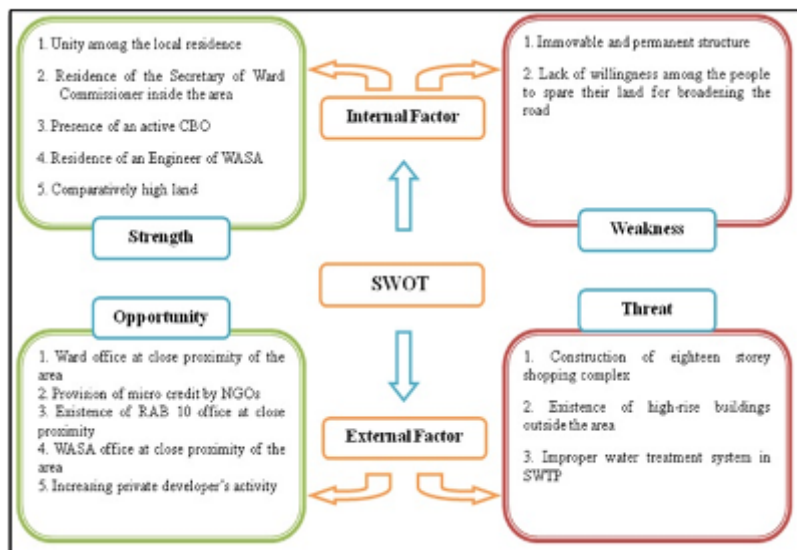
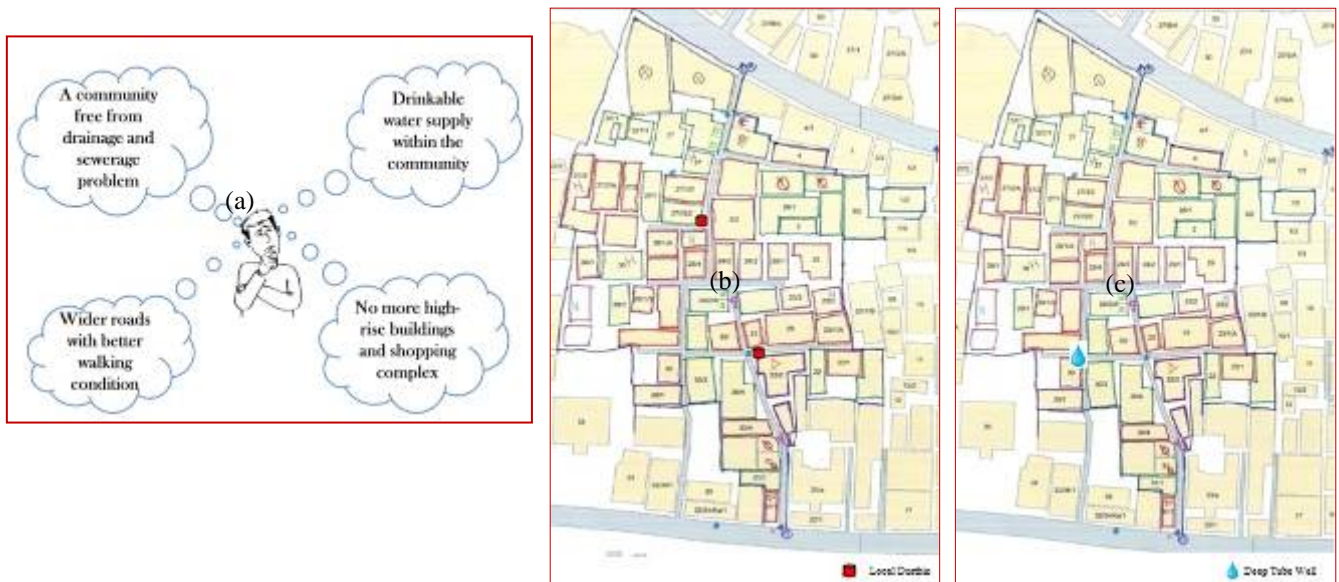

Figure 14: SWOT Analysis of *Lalbag* Society

SWOT analysis was also applied to make them cognizant about the potential weakness and threat toward solving these problems. Built structures are great weakness to the community that is hindering the possibilities to widen the narrow roads. Construction of high-rise buildings around the area will increase the pressure of traffic and can make the situation worse. Being aware of their potential strength, weakness, opportunities and threats it became effortless for the local people to find out the solutions to the problems. After conducting a Focus Group Discussion (FGD) with local people of the *Lalbag* society and some key informant interviews, a Dream map (Figure 15(a)) was prepared to perceive how they want to see their locality.



**Figure 15:** (a) Dream Map of *Lalbag* Society; (b) Possible Location of Local Dustbin; (c) Possible location of Deep Tube well

The first solution came up for the sewerage and drainage problem is to cover the open drains. Regular cleaning of the drains is also necessary to reduce the overflow of sewage. Dustbins can be placed at suggested locations (Figure 15(b)) so that people can use it and manage not to throw wastes in the open drains. Existing drain and sewer lines can be widened and deepened to increase the capacity. The CBO can undertake initiatives to implement these solutions with the help of the ward commissioner.

To address the problem of water crisis local people suggests that the field adjacent to the locality can be used to install a water extraction pump which will increase the water supply. The CBO can raise fund from the local people to buy the pump. Alternatively, they have suggested constructing large underground water reservoirs that can be established under the plots in which new buildings are going to be erected. This would not be so difficult because private developers' activity increasing here. Also, a deep tube well can be established at a suggested location by the local people as a source of free water supply for the locality (Figure 15(c)). Again the old water pipes can be replaced by new and improved quality pipes. Although it is not possible to change the old pipe line of houses that are in function but at the time of construction of new buildings it can be done easily.

Importance of maintaining building bye-laws during construction of houses is still unfamiliar to most of the residence of *Lalbag* community. The CBO can take the initiative to conduct meetings to guide local people about the benefit of maintaining bye-laws and regulations. Moreover the penalty of not maintaining these regulations can also motivate local people to become more concerned. To enhance the road condition damaged roads can be repaired by the CBO's own initiatives. Few of the roads that get submerged during rainy season can be raised higher. Ward commissioner can take initiatives regarding this proposal and increase the level of lower roads.

## 6. Conclusion:

Like other localities of Dhaka, *Lalbag* society is also overburdened with many problems. However, the problems can be solved by self-initiation of the community without entirely depending on the local level government. In this regard, the role of a CBO is cardinal to ensure active participation of the local people in addressing and remedying their own problems. This study tried to identify the local problems and solutions along with the local resources, strengths, weaknesses, opportunities, threats, through active participation of the



people of *Lalbag* Society. These problems were found to be condoned for a long time as the concerned authorities cannot always pay heed to the small local community. However after applying PRA tool it was found that the problems can be solved with the active functioning of CBO. Local people were prepared to find ways to install an extraction pump or to excavate an underground water reservoir which they considered to be a potential solution to the water quality and water supply problem. Regular cleaning of the open drains and widening of the existing drain and sewer lines, may improve poor drainage and sewerage condition. Increasing the level of road and enforcement of building bye-laws and regulations can improve the poor and narrow roads in the future. In order to implement the solutions CBO can play a vital role if adequate resource mobilization is assured. Besides, participation of local people will ensure more practical and desirable solutions along with higher level of accountability. Research results therefore indicate that, with sufficient mobilization of CBO, not only the study area but also other communities of Dhaka city can improve their condition. In this way, overall improvement of the city will be ensured with more active participation of community and less involvement of government authority.

### Glossary:

**Jamdani:** Jamdani is a valuable hand loom woven fabric made of cotton mostly used for sarees, scarves and handkerchiefs.

**Thana:** Sub-district

### References:

- Ahmed, B., Muhammad Rakibul Hasan Raj, M.R.H. and Maniruzzaman, K.M. (2009) "Morphological Change of Dhaka City Over a Period of 55 Years:A Case Study of Two Wards", *Journal of Bangladesh Institute of Planners* Vol. 2, December 2009, pp. 30-38, ISSN 2075-9363
- Banglapedia, (n.d.). *Lalbag Area*, Retrieved from URL: [http://www.banglapedia.org/httpdocs/HT/L\\_0028.HTM](http://www.banglapedia.org/httpdocs/HT/L_0028.HTM), accessed on 25 May, 2012
- Economic Commission of Latin America (1973) "Popular Participation in Development", *Community Development Journal*, Vol 8, No. 2, Oxford
- Enam, A. and Choudhury, C.F. (n.d.) "Methodological Issues in Developing Mode Choice Models for Dhaka City", Retrieved from URL: [http://teacher.buet.ac.bd/cfc/publications/Methodolical\\_TRB11.pdf](http://teacher.buet.ac.bd/cfc/publications/Methodolical_TRB11.pdf)
- Haque, A.M., Hossain, M.R., Farhan, M.H.M. and Neema, M.N. (2013), *An Innovative Approach to Assess the Quality of Major Parks in Environmentally Degraded Mega-City Dhaka*, proc. ICCSA 2013, Part III, LNCS 7973, 394–407.
- Hossain, S. (2008) "Rapid Urban Growth and Poverty in Dhaka City". *Bangladesh eJournal of Sociology*, Vol. 5, No.1, 2008.
- Jamdani Weavers' Community.(2008). Scope of Improvement of Living Condition and Occupational Status of a Jamdani Weavers' Community.Department of Urban and Regional Planning, Bangladesh University of Engineering and Technology.
- Kumar, S. (2002), *Methods for Community Participation: A Complete Guide for Practitioners*, Vistaar Publication, New Delhi, 2002
- McCracken, J.R. and Narayan, D. (1998) "Participation and Social Assessment: Tools and Techniques", Library of Congress Cataloging in Publication Data, Washington D.C. 1998, Retrieved from URL: <http://www.greenwonderland.co.uk/upload/document/participationtoolsandapproachs-worldbank.pdf>
- Mridha, R.U. (2008), "Old Dhaka business hubs in misery", The Daily Star, August 5, 2008, Retrieved from Website of a Bangladeshi Newspaper: <http://archive.thedailystar.net/newDesign/news-details.php?nid=48926>

NCBON (2004), What is a Community Based Organization (CBO)?, Retrieved from Website of Community Based Public Health Caucus: <http://www.sph.umich.edu/ncbon/whatis.html> Accessed on 10 October, 2013

Smities, J. and Wenster, G. (1998) *Community Involvement in health: from passive recipients to active participants*, Aldershot, Ashgate 1998.

# CYCLIC BENDING OF VARIOUS GLASS FIBRES REINFORCED WITH POLYMER COMPOSITE ARCHITECTURES

*Lecturer PhD. Eng. Mihai Alin Pop*

*Prof. PhD. Eng. Virgil Geamăn*

*Assoc. Prof. PhD. Eng. Dana Luca Motoc*

*Lecturer PhD. Mat. Vlad Monescu*

*Prof. PhD. Mat. Irinel Radomir*

Transilvania University of Brasov, Romania

---

## Abstract

The paper presents a contribution to the study and characterization of special composite materials based on resins reinforced with glass fiber and wire netting. Several tests were made previously for testing the behavior of the composites with resin reinforced with glass fiber to determine the physical and mechanical properties. There were used the following materials: Nestrapol 96 type resin reinforced with wire net with the specific weight of 400 [g/m<sup>2</sup>] and a number of 3, 5 and 7 layers, Stratimat type fiber glass with the specific weight of 300, 450 and 600 [g/m<sup>2</sup>] and a number of 3, 5 and 7 layers and a Tissue type fiber glass with the specific weight of 300 and 500 [g/m<sup>2</sup>]. The results obtained for those composites were compared with the results obtained for resin Nestrapol 96 without reinforcement. The second aim of this paper, was to make a mathematical modeling and an optimization of the resin type of composite materials reinforced with wire net and two types of fiber glasses. The modeling and optimization of these composites are based on the results obtained previously from the bending test and cyclical bending test.

---

**Keywords:** Bending, fiber glass, polymer, architecture, composite materials

## 1. Introduction

Composite materials are prospective materials replacing classical materials in many fields, for their good properties, characteristics and a short time for manufacturing. Composite materials are used increasingly in industry and have a very wide spread in many areas of activities.

These materials have better physical and mechanical properties reported to the wall thickness compared to conventional materials.

The use of certain light materials having specific properties in engineering, especially in the air force technique, needs a certain development of research in the field of aluminum alloys, which represents the basic raw material for a great number of components.

The estimation and measurement of composite materials effective properties, such as the mechanical (e.g. longitudinal, shear or bulk modules, Poisson ratio, etc), thermal (e.g. thermal conductivity or thermal expansion, etc.) or electrical (e.g. electrical conductivity, etc.) in terms of the phase properties and microstructure, is a lastingly standing issue.

This paper reports a comparative analysis between the behavior of the composite materials – obtained thanks to resins reinforced with different materials - at the bending and cyclic bending.

Nowadays there is a tendency to reduce the consumption of materials, to improve new technologies, to simplify and reduce the production time.

With the present paper the authors are trying to make a contribution to the study and characterization of thin-walled patterns made from composite resins reinforced with glass fibre.

To the best of our knowledge, this is the first time when this type of materials is used for making patterns in foundry.

## 2. Experimental researches and modeling

For experiments, were used the following materials:

### a). Resin - *Nestrapol 96\**

- It is an unsaturated, ortophtalic polyester resin. It is used to make the glass fibre reinforced parts for car bodies and sports and entertainment articles;
- application methods- spraying, brushing, roller;
- jellinging time - 6 - 8 minutes at 25°C; 4 - 9 minutes at 82°C;
- use of the articles- after minimum 7 days since complete hardening;

\* According to the information provided by the manufacturer of the resin

(Available from <http://www.industrial-coatings.eu/en/nestrapol-96-0>. Accessed: Nov.2012).

### b). Glass fibre:

- Stratimat with specific weight **300, 450 and 600 [g/m<sup>2</sup>]**;
- Tissue with specific weight **300 and 500 [g/m<sup>2</sup>]**
- Wire netting 0,8 with specific weight **400 [g/m<sup>2</sup>]**

### c). Cobalt accelerator 6507;

### d). Methyl - ethyl - cetone peroxide 50%;

### e). Hardener: D 605

Mechanical tests were made with The Universal Testing Machine, WDS-150S type.

These materials have been used to manufacture plate parts. The process for obtaining this plate composite was as follows:

- Preparing the patterns (the tray with elevated walls) for making the plates; applying the removing wax in order to prevent the resin to stick/adhere to the walls of the pattern; drying and polishing the contact surfaces between the pattern and resin.
- Preparing and cutting the fibre glass to the pattern dimensions.
- Applying resin layers successively by brushing; after applying each layer a tissue fibre glass sheet was placed by brushing. The process was repeated until the desired number of layers was reached.
- The notation when were used reinforcement materials are: tissue (**T1, T2 ... etc.**), stratimat (**S1, S2 ... etc.**), wire netting 0, 8 (**PS1, PS2 ... etc.**) and for mixed tissue and stratimat (**TS1, TS2 ... etc.**);

## 3. Result

For determining the initial characteristics for polyester resins type Nestrapol 96 were made testing samples for compressive strength, tensile strength, bending, shock resistance and the results are shown in Tables 1 - 3.

**Table 1.** The initial characteristics obtained for the Nestrapol 96 resin (symbols for the samples N1-A).

Resistance to		Average value	M.U.
Compression		159,54	N/mm <sup>2</sup>
Resilience		0,061	[J/cm <sup>2</sup> ]
Bending	Deflection of a girder	24,33	mm
	Bending resistance	21,55	N/mm <sup>2</sup>
Stress strain		34,87	N/mm <sup>2</sup>

Initial characteristics of the fibre glass:

- For tissue with specific weight  $300 \text{ g / m}^2$  we determined the tensile strength / wire:  $R_{t\text{-wire}} = 217, 26 \text{ [N/mm}^2\text{]}$
- For tissue with specific weight  $500 \text{ g / m}^2$  we determined the tensile strength / wire:  $R_{t\text{-wire}} = 519, 91 \text{ [N/mm}^2\text{]}$
- For the fibre glass stratimat type samples cannot be made to determine the tensile strength (fibre glass without resin).
- After determining the bending strength of these composite materials resin type reinforced with glass fibre the following were observed'

**Table 2.** Results obtained to bendings for the composite materials made in comparison with resins without reinforcement.

Type	Average breaking resistance to bending by type of sample [N/mm <sup>2</sup> ]
NTS 2	56.78
NT 1	54.85
NT 4	39.52
N1-A	21.55

**Table 3.** Group of composite materials and configuration

Plates	Insertion	No. of Layers	Specific weight [g / m <sup>2</sup> ]	Resin
N1-A	Resin	----	----	Nestrapol 96
NTS2	stratimat + tissue	1 + 2	300 + 300	
NT1	tissue	3	300	
NS4	stratimat	3	450	

## 4. Discussions

**4.1. Bending tests.** From the obtained glass fibre stratimat composites, the maximum resistance to bending is registered at the plate NS1 ( $30, 23 \text{ N/mm}^2$ ) and the maximum recorded value of deflection of girder at the plate NS1 (42 mm) as well.

The worst results were recorded for resistance to bending ( $12.85 \text{ N/mm}^2$ ) at NS6 plate and also the deflection of girder at plate NS6 (8.7 mm). *Bending strength and the value of deflection of girder decreases as the specific weight (for glass fibre) and the number of layers of insertion increases.*

From the obtained glass fibre tissue composites, the maximum resistance to bending is registered at the plate NT1 ( $54,85 \text{ N/mm}^2$ ) and the maximum value of deflection of girder at the plate NT6 (41,5 mm). The worst results were recorded for resistance to bending ( $21, 26 \text{ N/mm}^2$ ) at NT3 plate and also the deflection of girder at plate NT5 (12,1 mm).

*Bending strength and the value of deflection of girder decreases and the specific weight (for glass fibre) increases.*

From the composites obtained by combining glass fibre layers (stratimat and tissue), the maximum resistance to bending is registered at the plate NTS2 ( $56,78 \text{ N/mm}^2$ ) and the maximum value of deflection of girder at the plate NTS4 (37 mm). The worst results were recorded for resistance to bending ( $16,26 \text{ N/mm}^2$ ) at NTS3 plate and also the deflection of girder at plate NTS6 (11,3 mm).

*When are using mixed glass fibres, the composite properties are given by the majority of the glass fibre in the mass of the composite;*

If composites are obtained from the resins reinforced with wire netting, they are above the average of strength of glass fibre composites obtained from stratimat with specific weight 450 and  $600 \text{ g / m}^2$ , but lower than the composites made from tissue.

*Bending strength decreases as the number of layers of insertion increases;*

**4.1. Cyclic bending tests.** From plates previously made with best results to bending (Table 3) we made samples for the cyclic bending tests.

Tests were made by following steps: 5 samples from each material, 3 types of testings (1000 cyclic bending, 2000 cyclic bending, 3000 cyclic bending). In Fig. 1 is presented the Diagram for 1000 cyclic bindings

- The deformation of samples was approx. 2.4 mm for all samples.

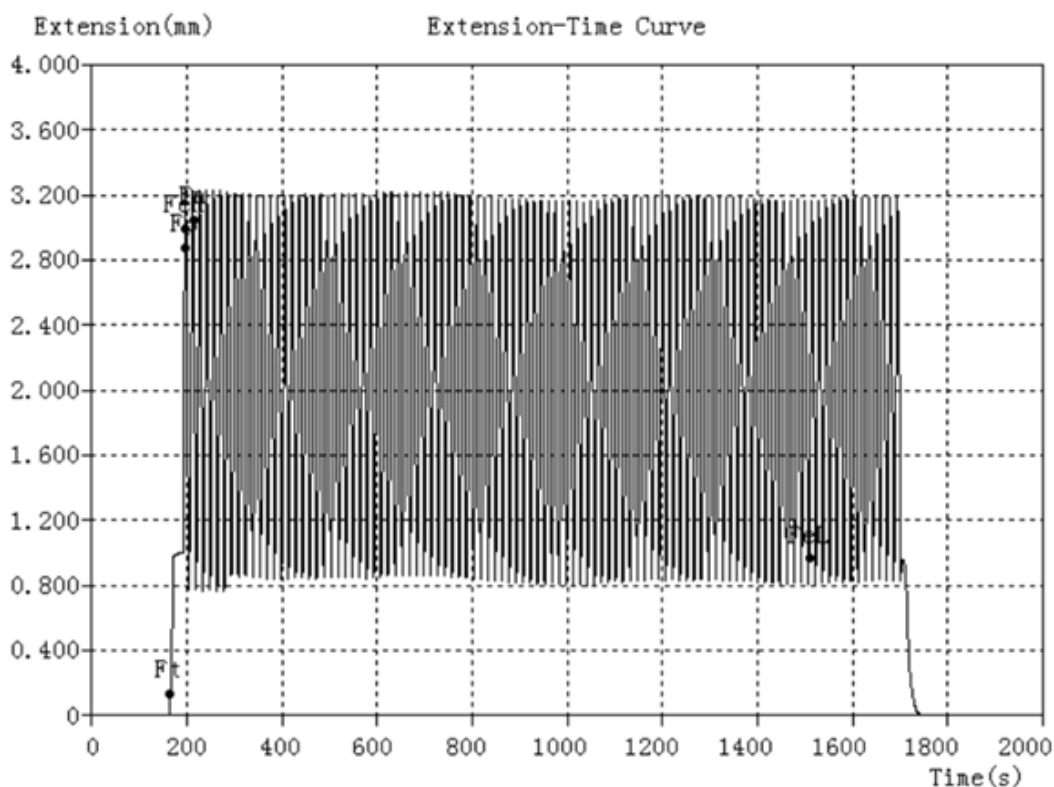

Fig. 1. Diagram for 1000 cyclic bendings.

After each test for all samples were determinate the resistance to bending. In Table 4 are presented the average of results.

**Table 4.** The average breaking resistance to cyclic bendings

Type	Average breaking resistance to cyclic bending by type of sample [N/mm <sup>2</sup> ]
1000 cycles	
NTS 2	55.64
NT 1	53.75
NT 4	38.73
N1-A	21.12
2000 cycles	
NTS 2	52.23
NT 1	50.46
NT 4	36.36
N1-A	19.83
3000 cycles	
NTS 2	48.26
NT 1	46.63
NT 4	33.59
N1-A	18.317

After analyzing the obtained results we can conclude:

- The resistance to bending is lower than the initial materials tested to bending without cycling bending, with approx. 1-2% for 1000 cycles, 7-8% for 2000 cycles and 14-15% for 3000 cycles.
- The resistance to bending decreases with increasing the number of bending cycles.

## 5. Final Conclusions

- From these materials it is recommended to obtain small and medium foundry patterns and the allowed pressure in the mixture is approx. 1 MPa.

- Because the resistance to bending decreases with increasing the number of bending cycles, the foundry patterns are recommended to be used of unique, small and medium production.

## References:

- Pop M. A., Constantinescu A.: Comparative study between the behaviour of composite resin reinforced with glass fibre. Mechanical properties, Proceedings of ModTech 2011. New Face of T.M.C.R., ISSN 2069 – 6736, pag. 889-893. Vadul lui Voda, Republica Moldova.
- Milosan I.: Theoretical aspects regarding of some metallurgical's processes optimization; *Metalurgia International*, Volume: 15; Issue: 8; ISSN: 1582-2214,2010, pag. 55 - 58
- Allaire G.: Numerical Analysis and Optimization. An introduction to mathematical modelling and numerical simulation, Oxford University Press, 2007
- Maxfield B.: Essential Mathcad For Engineering, Science, and Math, Elsevier, 2009.
- Mihai Alin POP, Alexandru CONSTANTINESCU: Manufacturing process for shell-type patterns utilised for moulds manufacturing. *Metalurgia* (60) no. 7 – 2008, ISSN 0461-9579.
- Mihai Alin POP, Alexandru CONSTANTINESCU: Utilisation of composites for shell-type patterns manufacturing. *Metalurgia International* vol. XIII (2008) – no.9, ISSN 1582-2214.
- Diana Elena APOSTU, Mihai Alin POP, Alexandru CONSTANTINESCU: Static loading of moulding thin-walled cave patterns manufactured of composite materials. *Metalurgia International* vol. XIV (2009) – Special Issue no. 10, ISSN 1582-2214.
- Mihai Alin POP, Alexandru CONSTANTINESCU : Determination of material properties for thin-walled composite resin reinforced with glass fiber. *Metalurgia* (62) no. 8– 2010, ISSN 0461-9579.
- Motoc Luca D., Pop P. A., Bejinaru, Gh.: A perspective in sizing the main influencing factors on the thermal properties of different metal/non-metal powders, *Metalurgia International*, vol. 4 (2011), p. 97, ISSN: 1582-2214, 2011.
- Gheorghe SIMIONESCU, Constantin CERNAT, M. PANA: Engineering of moulding process, Elvarom Publishing House, Bucuresti, 2000.
- Florin STEFANESCU, s.a: Composite Materials, Didactical and Pedagogical Publishing House, Bucuresti, 1996.
- Aurel IACOBESCU: Modern Materials and technologies for resistance structure construction of solid fuel rocketmotors, <http://www.actrus.ro>.
- Ioan MILOSAN: Some aspects about the processing of ceramic matrix composites (CMC) applied in automotive industry; *Metalurgia*, Volume: 62; Issue: 8; ISSN 0461-9579, 2010, pag. 29 – 31.
- Motoc Luca D., Novac Gh., Bejinaru Gh.: Measuring and characterizing CTE variations for multiphase polymeric composites subjected to extreme environmental conditions, *Metalurgia International*, vol. 1 (2011), Issue. 1, ISSN: 1582-2214, 2011.
- Virgil GEAMĂN, Mihai Alin POP: Microstructures of ATSi5Cu1 aluminum alloy processed by accumulative roll – bonding, *Metalurgia*, Volume: 64; Issue: 4; ISSN 0461-9579, 2012, pag. 9 – 13.
- Mihai Alin POP: Determining the optimum number of layers using mathematical modeling for composite materials depending on the resistance to bending, *Metalurgia International*, Volume: 17 (2012); Issue: 9; ISSN: 1582-2214,2012, pag. 42 – 45.
- Mihai Alin POP, Dana LUCA MOTOC, Alexandru CONSTANTINESCU, Virgil GEAMĂN, Rudolf Alexandru DERCZENI: CTE assessment of various glass fibre reinforced polymer composite architectures, *Metalurgia International* vol. XVIII (2013) – Special Issue no. 5, pag. 131-134, ISSN 1582-2214.

# EFFECT OF THICKNESS AND ANNEALING TEMPERATURE ON D.C. ELECTRICAL CONDUCTIVITY OF GaAs FILMS AND (C-V) CHARACTERIZATION OF GaAs/Ge HETEROJUNCTION

*Nahida B. Hasan*

Department of Physics, College of Science, University of Babylon , Iraq

*Maysoon F. Alias*

*Raad M. Al-Haddad*

Department of Physics, College of Science, University of Baghdad, Iraq

*Huda B. Hasan*

Department of Physics, College of Education, University of Babylon , Iraq

---

## Abstract

GaAs films with different thickness (0.4, 0.7, 1.0 and 1.5)  $\mu\text{m}$  have been prepared by thermal flash evaporation technique on glass substrate and Ge wafer at substrate temperature equal to 433K under vacuum of  $10^{-5}$  mbar with rate of deposition equal to 0.015  $\mu\text{m}/\text{min}$ . These films have been annealed at different annealing temperatures (473 and 523) K. The d.c. conductivity for all deposited films increases with thickness increases, and decreases with increase of annealing temperatures. The electrical activation energies ( $E_{a1}$ ) decrease with increasing of thickness and increase with increasing of annealing temperatures. Also GaAs/Ge heterojunction has been prepared at different thickness and annealing temperatures. The reverse bias capacitance was measured as a function of bias voltage at frequency 1 MHz, and it is indicated that these heterojunction are abrupt. The capacitance decreases with increasing the reverse bias voltage, also with increasing of thickness and annealing temperatures. The width of depletion layer increases with increase of the thickness and annealing temperatures respectively. The value of built-in voltage varies between (0.56–1.08) Volt when thickness changes from 0.4 to 1.5 $\mu\text{m}$ .

---

## 1. Introduction

In recent years researches have worked on various semiconductors to supplement germanium and silicon for use in electronic applications. Among many elements appear particularly usefully interesting were the compounds formed from group III and V of the periodic Table, such as GaAs, GaP, InSb, etc.[1].

III–V compounds provide the basis materials for a number of well established commercial technologies, as well as new cutting – edge classes of electronic and optoelectronic devices, which include high electron mobility and heterostructure bipolar transistor, diode laser, light emitting diodes, photo detector electro-optic modulators, and frequency mixing components [2]. GaAs is III–V compound semiconductor composed of the element gallium (Ga) from column III and the element arsenic (As) from column V of the periodic Table. GaAs was first created by Goldschmidt and reported in 1929, but the first reported interesting electronic properties of III–V compounds as semiconductors was at until 1952 [3].



The cubic zinc–blende structure of GaAs consists of two interpenetrating face centered cubic with the atoms tetrahedrally coordinated. In GaAs, each arsenic atom (with five valence electrons) and each gallium atom (with three valence electrons) has four neighboring from the versus element. And gallium arsenide can be considered a covalent bonded semiconductor. The most probable value for the lattice constant of GaAs as obtained by extrapolation of the mean values is given as  $a = 5.65315 \pm 0.0001 \text{ \AA}$  [4]. The lattice constant is therefore independent of the stoichiometry of the mixture of the components used in the preparation of GaAs, i.e., stoichiometric GaAs can be prepared from either arsenic or gallium – rich mixtures [5].

## 2-Experimental

The preparation of GaAs films with satisfactorily reproducible properties demands special technological procedures. Therefore, flash evaporation techniques were chosen in the present investigation [6].

The electrical resistance has been measured as a function of temperature for GaAs films in the range (303–503) K . The measurements have been done using sensitive digital electrometer type Keithley 616 and electrical oven.

The resistivity ( $\rho$ ) of the films is calculated by using the following equation:

$$\rho = \frac{R.A}{L} \dots\dots\dots(1)$$

Where R is the sample resistance, A is the cross section area of the film and L is the distance between the electrodes. The conductivity of the films was determined from the relation:

$$\sigma_{d.c.} = \frac{1}{\rho} \dots\dots\dots(2)$$

The activation energies could be calculated from the plot of  $\ln\sigma$  versus  $10^3/T$  according to equation (3).

$$\sigma = \sigma_0 \exp(-E_a/k_B T) \dots\dots\dots(3)$$

Where  $\sigma_0$  is the minimum electrical conductivity at 0K,  $E_a$  is the activation energy which corresponds to  $(E_g/2)$  for intrinsic conduction, T is the temperature and  $k_B$  is the Boltzmann's constant [7].

The capacitance of the heterojunction was measured as a function of the reverse bias voltage at the range (0–1) Volt with fixed frequency of 1 MHz by using HP–R2C unit model 4274A and 4275A multi–frequency LRC meter.

This measurement was used to determine the type of the heterojunction (abrupt or graded), built in voltage ( $V_{bi}$ ), carrier concentration and finally the width of depletion layer. The value of built – in voltage can be found from the plots of the relation between  $1/C^2$  and the reverse bias voltage, then the interception of the straight line with the voltage axis represents the built – in voltage. The width of the junction can be deduced from the following equation:

$$W = \epsilon_s/C_0 \dots\dots\dots(4)$$

Where  $C_0$  is the capacitance at zero biasing voltage, and

$$\epsilon_s = \frac{\epsilon_n \epsilon_p}{\epsilon_n + \epsilon_p} \dots\dots\dots(5)$$

The concentration of carriers was calculated from the relation [8]:

$$\frac{1}{C^2} = \left[ \frac{2(\epsilon_p N_p + \epsilon_n N_n)}{q N_p N_n \epsilon_p \epsilon_n} \right] \cdot (V_D - V) \dots\dots\dots(6)$$

Where  $[2(\epsilon_p N_p + \epsilon_n N_n)/q N_p N_n \epsilon_p \epsilon_n]$  represent the slope.

The rise time can be obtained from the relation:

$$t_r = RC \dots\dots\dots(7)$$

The response time is calculated from the relation [9]:

$$t_{\text{response}} = t_r / 2.2 \dots\dots\dots (8)$$

### 3-Results and Discussion

#### 3-1 D.C. Electrical Conductivity

The variation of electrical conductivity as a function of temperature for different thicknesses and  $T_a$  is shown in Fig.(1). It is clear from this figure that the conductivity for all deposited films increases with thickness. These results are close to those obtained by Segui et al.[10] for GaAs films prepared by plasma deposition method. Also it is observed that the conductivity of the films decreases with increasing of  $T_a$  from 473 K to 523 K. This variation is thought to be due to the changes in the crystallization (reduction of the number of grain boundaries due to the increase of the grain size) of the films. Thin film conductivity measured at room temperature ( $\sigma_{R,T}$ ) was about  $(0.13 \times 10^{-3}, 0.09 \times 10^{-3}$  and  $0.04 \times 10^{-3}) \Omega^{-1} \cdot \text{cm}^{-1}$  at R.T and annealing temperatures (473 and 523) K, respectively for thickness equals to 0.4  $\mu\text{m}$ , and  $(9.7 \times 10^{-3}, 8.1 \times 10^{-3}$  and  $7.7 \times 10^{-3}) \Omega^{-1} \cdot \text{cm}^{-1}$  for thickness equals to 1.5  $\mu\text{m}$ . The variation of  $\sigma_{R,T}$  when thickness varies from 0.4 to 1.5  $\mu\text{m}$  for all annealing temperatures is given in Table (1). These results are in agreement with Islam and Mitra.[11], El-Wahhab [12] and Segui et al.[10]. From figure (2) and Table (1) we can observe that  $\sigma_{R,T}$  increases with increasing of thickness but decreases with increasing of annealing temperatures, because of the rearrangement that may occur during annealing at temperatures higher than substrate temperatures which produce an irreversible process in the conductivity [13].

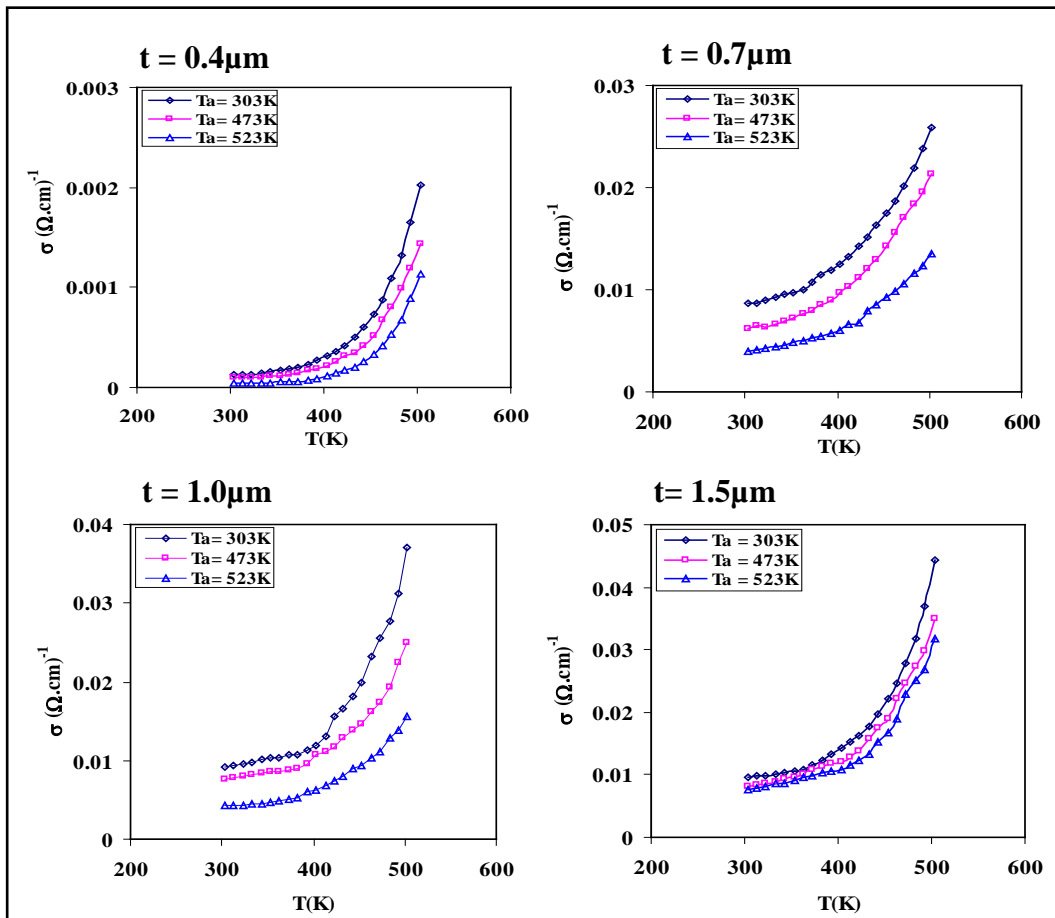

Fig.(1) Variation of  $\sigma_{D,C}$  versus temperatures for GaAs films prepared at different thickness and annealing temperatures.

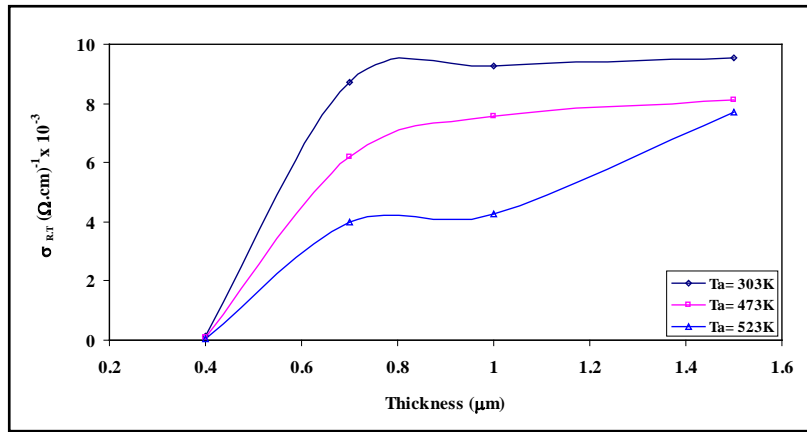

Fig.(2)Variation of  $\sigma_{R,T}$  versus thickness for GaAs films at different annealing temperatures.

The plots of  $\ln\sigma$  versus  $10^3/T$  for GaAs films in the range (303-503) K at different thicknesses and annealing temperatures, are shown in Fig.(3). It is clear from this figure that there are two transport mechanisms, giving rise to two activation energies  $E_{a1}$  and  $E_{a2}$ . The conduction mechanism of the activation energy ( $E_{a2}$ ) at the higher temperatures range (403-503) K is due to carrier's excitation into the extended states beyond the mobility edge, and at the lower range of temperatures (303-393) K, the conduction mechanism is due to carrier's excitation into localized state at the edge of the band [14]. Table (1) and Fig.(4) show the effect of thickness and annealing temperature on both activation energies  $E_{a1}$  and  $E_{a2}$  for GaAs films. It is clear that the activation energies decrease with increasing of the thickness but increase with increasing of annealing temperatures. These results are in agreement with Islam and Mitra.[11], El-Wahhab [12] and Segui et al.[10].

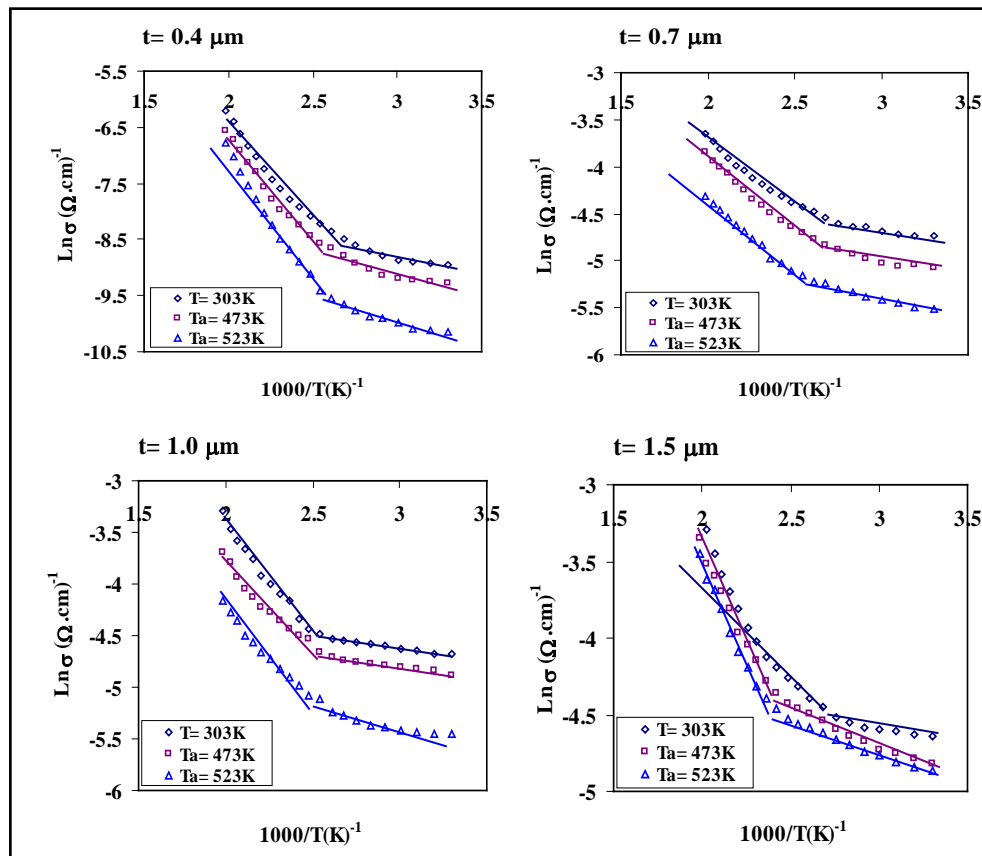
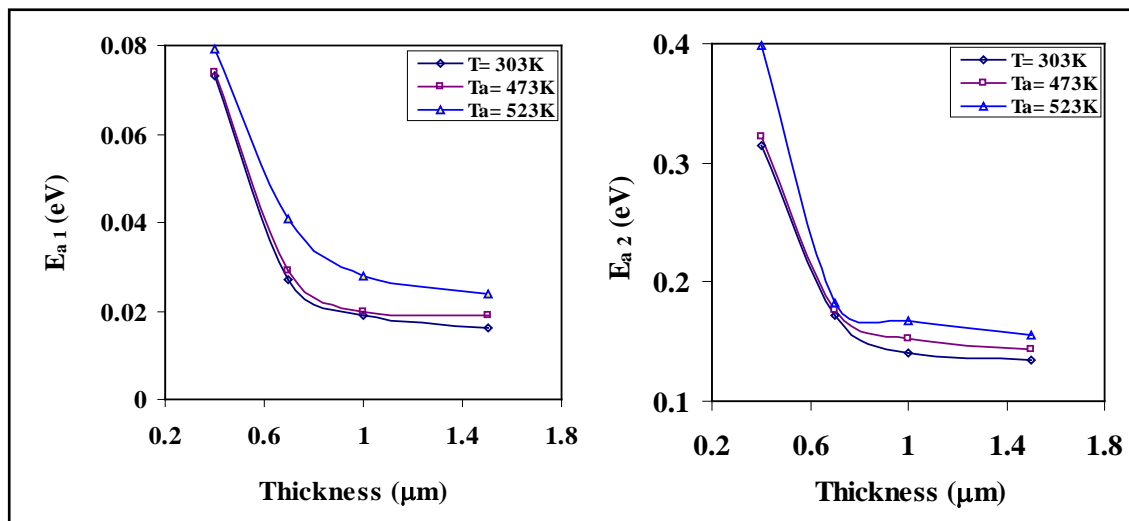

Fig.(3)  $\ln\sigma$  versus  $1000/T$  for GaAs films at different thickness and annealing temperatures.

The activation energy  $E_{a1}$  for GaAs films at thickness 0.4  $\mu\text{m}$  increases with increasing of annealing temperature when annealing temperature changes from 473 to 523 K. Similar behavior of films appears for other thicknesses as shown in Table (1). The decreasing in the activation energy with increasing of thickness may be due to the increase of the absorption and the decrease of energy gap with increasing of thickness.

Thickness ( $\mu\text{m}$ )	$T_a$ (K)	$\sigma_{R,T} \times 10^{-3}$ ( $\Omega.\text{cm}$ ) <sup>-1</sup>	$E_{a1}$ (eV)	Temp.Range (K)	$E_{a2}$ (eV)	Temp.Range (K)
0.4	303	0.13	0.073	(303-383)	0.315	(393-503)
	473	0.09	0.074	(303-383)	0.322	(393-503)
	523	0.04	0.079	(303-393)	0.399	(403-503)
0.7	303	8.72	0.027	(303-373)	0.172	(383-503)
	473	6.20	0.029	(303-363)	0.177	(373-503)
	523	4.00	0.041	(303-403)	0.183	(413-503)
1.0	303	9.26	0.019	(303-413)	0.141	(423-503)
	473	7.58	0.020	(303-393)	0.153	(403-503)
	523	4.27	0.028	(303-383)	0.168	(393-503)
1.5	303	9.52	0.016	(303-363)	0.134	(373-503)
	473	8.10	0.019	(303-403)	0.143	(413-503)
	523	7.72	0.024	(303-403)	0.155	(413-503)

**Table (1)** D.C. conductivity parameters for GaAs films at different thicknesses and annealing temperatures.



**Fig.(4)** Variation of  $E_{a1}$  and  $E_{a2}$  for GaAs films at different thickness and annealing temperatures.

### 3-2 C-V Characteristic of GaAs/Ge Heterojunction

The variation of capacitance as a function of reverse bias voltage in the range of (0-1) Volt at frequency equal to 1 MHz has been studied, for GaAs/Ge heterojunction at different thickness and annealing temperatures as shown in Fig.(5). It is clear that the capacitance decreases with increasing of the reverse bias voltage and annealing temperatures. This result is confirmed by equation (6) and the decreasing was non-linear as shown in Fig.(5). Such behavior is attributed to the increasing in the depletion region width, which leads to increase of the value of built-in voltage. This effect has been studied by Sah and Reddi.[15], Milnes and Feucht.[8] and Ghandhi *et al.*[16] and our results are in agreement with their results.

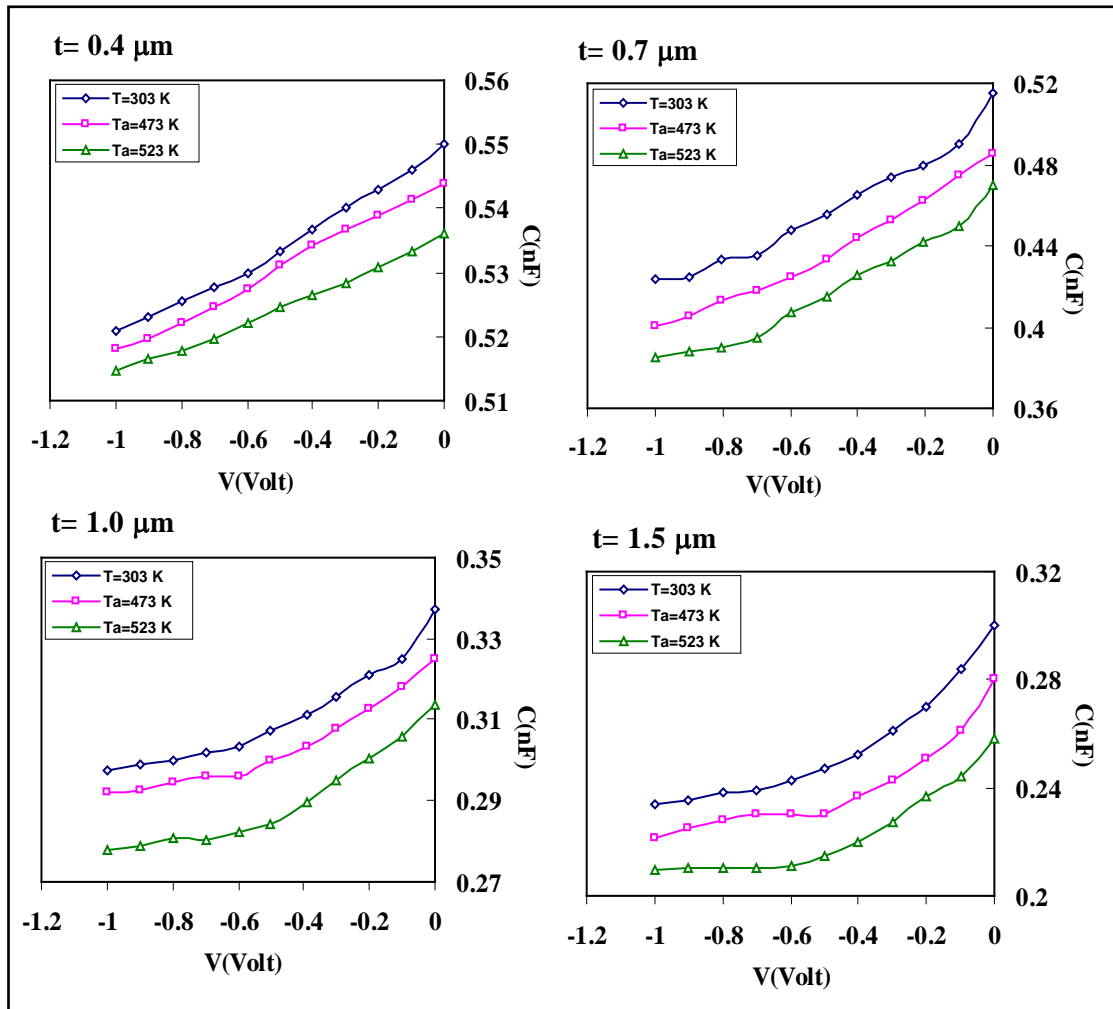

Fig.(5) The variation of capacitance as a function of reverse bias voltage for GaAs/Ge heterojunction at different thicknesses and annealing temperatures.

We can observe from Table (2), that the capacitance at zero bias voltage ( $C_0$ ) decreases with the increasing of the annealing temperatures for all prepared junctions and this is attributed to the decrease in the surface states which leads to an increase in the depletion layer and a decrease of the capacitance. The width of depletion layer can be calculated using equation (4). We can notice from Table (2) that the depletion width increases with increasing of the annealing temperature which is due to the decreasing in the carrier concentration which leads to a decrease of the capacitance as given in Table (2). Such behavior is nearly in agreement with Ryu and Takashi [17] and Gandhi *et al.*[18]. The effect of thickness as well as annealing temperatures are shown in Fig.(5). We observe that the capacitance is decreases with increasing of GaAs thickness. This result is confirmed by the equation ( $C = A \epsilon_s / L$ ) [19,20], where  $A$  is the active area of the junction and  $\epsilon_s$  and  $L$  are the dielectric constant and thickness of the semiconductor layer respectively. We relate such data as behavior due to the increasing of the depletion region. The variation of zero bias capacitance ( $C_0$ ) as a function of thickness for GaAs/Ge heterojunction at R.T and different annealing temperatures (473 and 523) K is shown in Fig.(6).

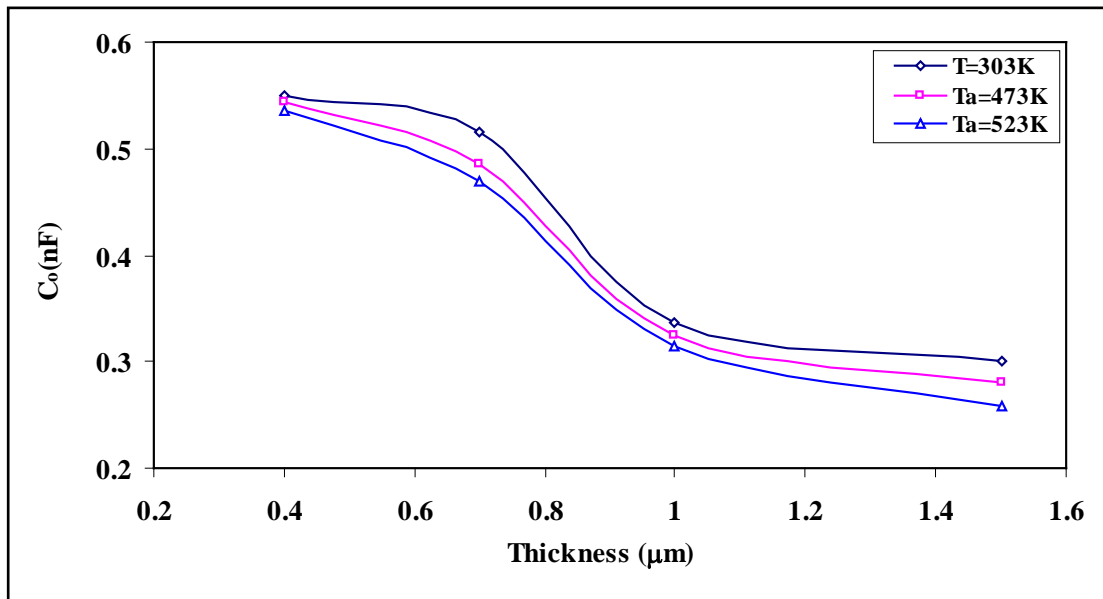

Fig.(6) Variation of zero bias capacitance as a function of thickness for GaAs/Ge heterojunction at different annealing temperatures.

Also from the value of zero bias capacitance ( $C_o$ ) the rise time ( $t_r$ ) and response time ( $t_{\text{response}}$ ) have been calculated from equations (7) and (8) respectively as given in Table (2). It is observed that the rise and response times decrease with increasing both thickness and annealing temperatures.

Table (2) The variation of the  $C_o$ ,  $W$ ,  $N_D$ ,  $V_{bi}$ ,  $t_{\text{rise}}$  and  $t_{\text{response}}$  for GaAs films with different thicknesses and annealing temperatures.

Thickness ( $\mu\text{m}$ )	$T_a$ (K)	$C_o$ (nF)	$W$ ( $\mu\text{m}$ )	$N_D$ ( $\text{cm}^{-3}$ )	$V_{bi}$ (Volt)	$t_r$ (ns)	$t_{\text{respon}}$ (ns)
0.4	303	0.550	0.473	$0.228 \times 10^{13}$	0.56	27.5	12.5
	473	0.544	0.479	$0.272 \times 10^{13}$	0.64	27.2	12.4
	523	0.536	0.486	$0.308 \times 10^{13}$	0.70	26.8	12.2
0.7	303	0.515	0.506	$0.580 \times 10^{12}$	0.74	25.8	11.7
	473	0.485	0.537	$0.446 \times 10^{12}$	0.80	24.3	11
	523	0.470	0.554	$0.472 \times 10^{12}$	0.88	23.5	10.7
1.0	303	0.337	0.773	$0.294 \times 10^{12}$	0.90	16.9	7.66
	473	0.325	0.801	$0.297 \times 10^{12}$	0.93	16.3	7.39
	523	0.314	0.830	$0.234 \times 10^{12}$	0.96	15.7	7.13
1.5	303	0.300	0.868	$0.764 \times 10^{11}$	0.98	15.0	6.82
	473	0.280	0.929	$0.926 \times 10^{11}$	1.02	14.0	6.36
	523	0.258	1.01	$0.970 \times 10^{11}$	1.07	12.9	5.86

The inverse capacitance square is plotted against applied reverse bias voltage for GaAs/Ge heterojunction at different thicknesses and annealing temperatures as shown in Fig.(7). The plots revealed straight line relationship which means that the junction was of an abrupt type. This is in agreement with the results of Ryu and Takashi [80], Nathan and Marinace [21], Jain and Melehy [22] and Milnes and Feucht [8]. The interception of the straight line with the voltage axis at ( $1/C^2 = 0$ ), represents the built-in voltage [23]. We observed from Table (2) that the built-in voltage increases with increasing of  $T_a$  as a result of the decrease in the capacitance value and the increase of the depletion width. Also we can observe that the effect of increasing of the thickness causes an increase in the built-in

voltage as given in Table (2). From the same figure, we have deduced the carrier's concentration of the abrupt GaAs/Ge heterojunction at different thicknesses and  $T_a$  from the slope of the straight line by using equation (6). Table (2) exhibits that these values which decrease with increasing thickness and they increase with increasing ( $T_a$ ) for 0.4 and 1.5  $\mu\text{m}$  thickness while for other values of that  $N_D$  decreases.

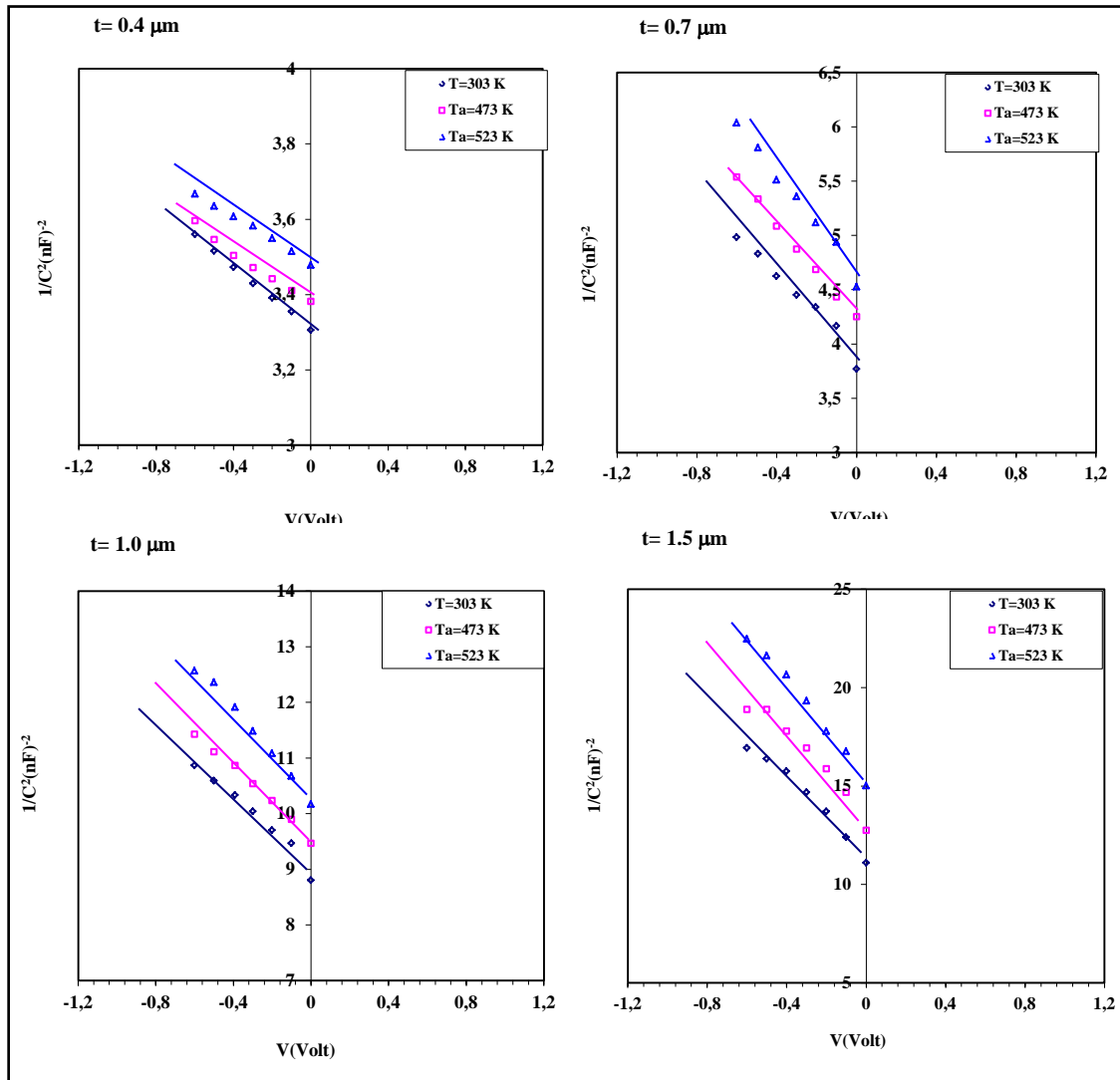

Fig.(7) The variation of  $1/C^2$  as a function of reverse bias voltage for GaAs/Ge heterojunction at different thicknesses and annealing temperatures.

#### 4- Conclusions

1. The d.c. conductivity for all deposited films increases as the thickness increases, and decreases with increasing of annealing temperature from 473 K to 523 K.
2. There are two transport mechanisms of the charge carriers in the range of temperatures (303–503) K.
3. The activation energies decrease with increasing of the thickness and increase with increasing the annealing temperatures.
4. The capacitance decreases with increasing of the reverse bias voltage, thickness and annealing temperatures.
5. The width of the depletion layer increases with increasing of the thickness and annealing temperatures.
6. The junction was of an abrupt type.

7. The value of built – in voltage increases with increasing of the thickness and annealing temperatures for all samples.
8. The carrier's concentration for GaAs /Ge heterojunction decreases with increasing of thickness, while its variation with annealing temperature, is not systematic.
9. The rise and response times decrease with increasing of thickness and annealing temperatures for all samples.

### References:

1. R.E.J.King and B.E.Bartlett, *Philips Technical Review*, Vol.22, No.3, pp. 217-221,(1961).
2. I. Vuraftman, J.R. Meyer and L.R.Ram.Mohan, *Journal of Applied Physics*, Vol.89, No.11,(2001).
3. S.Kayali, J.Ponchak and R.Shaw "GaAs MMIC Reliability Assurance Guide Line for Space Applications" NASA (1996). <http://www.Google.com>
4. Ghandi and Sorab, "*VLSI Fabrication Principles-Silicon and GaAs Arsenide*", John Wiley and Sons Inc, USA, (1983).
5. R.K.Willardson and Albert C.Beer "*Semiconductor and Semimetal*" Vol. 2, Academic Press, Inc. London LTD (1975).
6. B.L.Sharma and R.K.Purohit, "*Semiconductor Heterojunctions*", Pergamon Press, Oxford, New York (1974).
7. P.S.Kireev, "*Semiconductors Physics*", Translated from Russian by M.Samokhvalov, MIR Publishers, Moscow (1978).
8. A.G.Milnes and D.L.Feucht, "*Heterojunctions and Metal-Semiconductor Junctions*", Academic Press, New York and London (1972).
9. P.W.Krus, "*Optical and Infrared Detectors*", edited by R.J.Keyes, Springer – Verlag Berlin, Heidelberg, Vol.19 (1977).
10. Y.Segui, F.Carrere and A.Bui, *Thin Solid Films*, Vol.92, pp.303-310 (1982).
11. M.N.Islam and S.K.Mitra, *Journal of Materials Science*, Vol.24, pp.2863-2865 (1986).
12. M.A.El-Wahhab "*Schottky Diode of In/GaAs/Au-Ag Films Prepared by Flash Evaporation*", M.Sc., University of Baghdad (2006).
13. A.Gheorghiu and M.L.Theye, *Philos. Mag.*, B 44, 6, pp.285-290 (1981).
14. M.Mott and E.Davis, "*Electronic Process in Non-Crystalline Materials*" 2<sup>nd</sup> edition, Oxford University Press (1979).
15. J.L.Richards, P.B.Hart, and L.M.Gallone, *J. Appl. Phys.*,Vol.34, p.3418-3420 (1963).
16. W.R.Frensley, and H.Kroemer, "*J. Vac. Sci. Technol.*", Vol.13, No.4, pp.810-815 (1976).
17. In-Soun Ryu, and Kiyoshi Takashi, *Japanese Journal of Applied Physics*, Vol.4, No.11, pp.850-853 (1965).
18. S.K.Ghandhi, S.K.Shastry and J.M.Borrego, *Appl. Phys. Lett.*, Vol.38, No.1, pp.25-27 (1981).
19. T.Henry Minden, *J.Chem.Phys.*, Vol.23, No.10, pp.1948-1955 (1954).
20. E.H.Rhoderic and R.H.Williams, "*Metal Semiconductor Contacts*", Clarendon Press, Oxford (1988).
21. M. I.Nathan and J.C.Marinace, *Physical Review*, Vol.128, No.5, pp.2149-2152 (1962).
22. F.C.Jain, and M.A.Melehy, *Applied Physics Letters*, Vol.27, No.1, pp.36-38 (1975).
23. B.G.Streetman, "*Solid State Electronic Devices*" Prentice – Hall, Inc, printed Englewood,USA, Chapter One, 126, pp12-24 (1980).



# NO REFERENCE IMAGE QUALITY ASSESSMENT DEPENDING ON YCbCr AND L\*u\*v\*

*Musa Kadhim Mohsin*

Physics Department, College of Science, Babylon University, Iraq

---

## Abstract

Image quality assessment is a complicated and hard process, because of its independent on reference image, this process is done by some no reference metrics. In this paper the quality of images were assessed by a no reference metric, this metric is (The entropy of first derivative (EFD)), also Gaussian blurring were assumed as a distortion, and to estimate the efficiency of the no reference metric in assess the quality of colored images it is necessary to compare the results with the results of some reference metrics, we depended on (Normalize mean square error (NMSE) and structural similarity index measurement (SSIM)) as a reference metrics. Furthermore, two color spaces were applied (YCbCr and L\*u\*v\*) to find the best color space to working on. In the first step of the work the selected images were distorted by Gaussian blurring then the quality of the distorted images were measured by the reference metrics, this is done in the two color spaced were used, after that the no reference metric were applied to assess the quality of the distorted images, finally, the results were compared with the results of the reference metrics by plotting and by finding the correlation coefficients between the carves of reference and no reference metrics to find the best color space to working on.

---

**Keywords:** No reference image, EFD, quality assessment, YCbCr and L\*u\*v\*

## 1.Introduction:

Objective image quality measures have been developed to quantitatively predict perceived image quality. They are of fundamental importance in numerous applications, such as to benchmark and optimize different image processing systems and algorithms, to monitor and adjust image quality, and to develop perceptual image compression and restoration technologies, etc. As an important approach for objective image quality assessment, noreference image quality assessment seeks to predict perceived visual quality solely from a distorted image and does not require any knowledge of a reference (distortion-free) image. Noreference image quality measures are desirable in applications where a reference image is expensive to obtain or simply not available. The intrinsic complexity and limited knowledge of the human visual perception pose major difficulties in the development of no-reference image quality measures. The field of noreference image quality assessment remains largely unexplored and is still far from being a mature research area. Despite its substantial challenges, the development of noreference image quality measures is a rapidly evolving research direction and allows much room for creative thinking [1]. In 2007, F. Crete et al, suggested a no reference quality to estimate the blur distortion by computing the intensity variations between neighboring pixels of the input image [2], also in 2008, Xin Wan et al, presents a noreference blur metric for images and video using information contained in the image itself, they look at the sharpness of the sharpest edges in the blurred image, which contains information about the blurring [3], furthermore R. Ferzli et al, In 2009, presents a perceptual-based noreference objective image sharpness/blurriness metric by integrating the concept of just noticeable blur into a probability summation model [4], but H. G. Al-Khuzaiin

2011, suggested a no reference quality to measure the quality of the color image based on changing in lightness and contrast [5], as well, A. Chetouani et al, in 2012, proposed a no reference image quality assessment according to the degradation type by detecting and identifying the type of the degradation contained in the image before quantifying its quality [6]. In this paper a no reference metric were applied to assess the quality of blurred color images, considering two color spaces (YCbCr and L\*u\*v\*).

## 2. Image quality measurement (IQM):

Measuring the quality of image is a complicated and hard process since humans opinion is affected by physical and psychological parameters. Many techniques are proposed for measuring the quality of the image but none of it is considered to be perfect for measuring the quality. Image quality assessment plays an important role in the field of image processing [7]. Image quality metrics are divided in to two kinds subjective and objective, human visual system (HVS) is an example of subjective IQM. Most IQM are related to the difference between two images (the original and distorted image) and this type is called reference IQM, other IQM are not related to the difference between the two images like reduce reference IQM and no reference IQM.

## 3. No reference image quality metrics:

No reference image quality refers to the problem of predicting the visual quality of image without any reference to an original optimal quality image. This assessment is the most difficult problem in the field of image objective analysis [8], since many unquantifiable factors play a role in human perceptions of quality, such as aesthetics, cognitive relevance, learning, context...etc. [9]. No reference image quality is useful to many still image applications as assessment equality of high-resolution image, JPGE image compressed [10] moreover, this objective method can measure image equality depending on verity of lightness and contrast.

## 4. Mean and Normalize Squared Error (MSE), (NMSE)

The simplest and most widely used fidelity measure is the mean squared error (MSE) and the corresponding distortion metric, is given by [11]:

$$MSE = \sum_{x=1}^M \sum_{y=1}^N (I_n(x, y) - I(x, y))^2 \dots \dots \dots (1)$$

And the Normalization Mean Squared Error (NMSE) is defined as [11]:

$$NMSE = \frac{\sum_{x=1}^M \sum_{y=1}^N (I_n(x, y) - I(x, y))^2}{\sum_{x=1}^M \sum_{y=1}^N I^2(x, y)} \dots \dots \dots (2)$$

## 5. Structural Similarity Index Measurement (SSIM):

Wang et al [12], proposed structural similarity index as an improvement for universal image quality index UIQI, the mean structural similarity index is computed as follows: Firstly, the original and distorted images are divided into blocks of size (8 \* 8) and then the blocks are converted into vectors. Secondly, two means and two standard derivations and one covariance value are computed from the images as in (3), (4) and (5) [12].

$$\mu_x = \frac{1}{T} \sum_{i=1}^T x_i \quad \mu_y = \frac{1}{T} \sum_{i=1}^T y_i \dots \dots \dots (3)$$

$$\sigma_x^2 = \frac{1}{T-1} \sum_{i=1}^T (x_i - \bar{x})^2 \quad \sigma_y^2 = \frac{1}{T-1} \sum_{i=1}^T (y_i - \bar{y})^2 \dots \dots \dots (4)$$

$$\sigma_{xy}^2 = \frac{1}{T-1} \sum_{i=1}^T (x_i - \bar{x})(y_i - \bar{y}) \dots \dots \dots (5)$$

where  $x_i$  and  $y_i$  correspond to two different images, i.e. two different blocks in two separate images,  $\mu_x, \mu_y, \sigma_x^2, \sigma_y^2$  and  $\sigma_{xy}^2$  are the mean of  $x_i$ , the mean of  $y_i$ , the variance of  $x_i$ , the variance of  $y_i$ , and the covariance of  $x_i$  and  $y_i$  respectively

Thirdly, luminance, contrast, and structure comparisons based on statistical values are computed like in UIQI, the structural similarity index measure between images  $x$  and  $y$  is given by (2.8) [11].

$$SSIM(x, y) = \frac{(2\mu_x\mu_y + c_1)(2\sigma_{xy} + c_2)}{(\mu_x^2 + \mu_y^2 + c_1)(\sigma_x^2 + \sigma_y^2 + c_2)} \dots \dots \dots (6)$$

Where  $c_1$  and  $c_2$  are constants. SSIM is more accurate and consistence than MSE despite its cost more.

**6.YCbCr color space:**

The YCbCr color space is used widely in digital video. In this format, luminance information is represented by a single component, Y, and color information is stored as two color difference components Cb and Cr. Component Cb is the difference between the blue component and a reference value, and component Cr is the difference between the red component and a reference value [13]. The transformation used by IPT to convert from RGB to YCbCr is [14]:

$$\begin{bmatrix} Y \\ Cb \\ Cr \end{bmatrix} = \begin{bmatrix} 16 \\ 128 \\ 128 \end{bmatrix} + \begin{bmatrix} 65.481 & 128.553 & 24.966 \\ -37.797 & -74.203 & 112.000 \\ 112.000 & -93.786 & -18.214 \end{bmatrix} * \begin{bmatrix} R \\ G \\ B \end{bmatrix} \dots \dots \dots (7)$$

**7.CIE L\*u\*v\* color space**

This color space is based on the CIE Yu'v' color space and is a further attempt to linearize the perceptibility of unit vector color differences. It is a non-linear color space, but the conversions are reversible. Coloring information is centered on the color of the white point of the system, subscript n, (D65 in most TV systems). The non-linear relationship for Y\* is intended to mimic the logarithmic response of the eye [15].

$$L^* = \begin{cases} 116 \left(\frac{Y}{Y_n}\right)^{13} - 16 & \text{if } \frac{Y}{Y_n} > 0.008856 \\ 903.3 \left(\frac{Y}{Y_n}\right) & \text{if } \frac{Y}{Y_n} \leq 0.008856 \end{cases} \dots \dots \dots (8)$$

$$u^* = 13(L^*)(\acute{u} - \acute{u}_n) \dots \dots \dots (9)$$

$$v^* = 13(L^*)(\acute{v} - \acute{v}_n) \dots \dots \dots (10)$$

$L^*$  scales from 0 to 100 for relative luminance  $\left(\frac{Y}{Y_n}\right)$  scaling from 0 to 1.

**8.Gaussian blurring**

The Gaussian blur is a type of image-blurring filter that uses a Gaussian function for calculating the transformation to apply to each pixel in the image [16,17]. The equation of a Gaussian function in two dimensions of the position  $x,y$  is given by:

$$G(x, y) = \frac{1}{\sqrt{2\pi s^2}} e^{-\frac{x^2+y^2}{2s^2}} \dots \dots \dots (11)$$

Where  $x$  is the distance from the origin in the horizontal axis,  $y$  is the distance from the origin in the vertical axis, and  $s$  is the standard deviation of the Gaussian distribution (sigma). When applied in two dimensions, this formula produces a surface whose contours are concentric circles with a Gaussian distribution from the center point.

Values from this distribution are used to build a convolution matrix that is applied to the original image. The blurring image is given by [14].

$$Ib = I * G \dots \dots \dots (12)$$

Where  $I$  is the original image,  $G$  is Gaussian function and  $Ib$  is the resulted blur image.

If we applied equation (11) in frequency domain, this can be done by using Fourier transform that given by [14]:

$$F(u, v) = \frac{1}{MN} \sum_{x=0}^{M-1} \sum_{y=0}^{N-1} I(x, y) e^{-i2\pi(\frac{ux}{M} + \frac{vy}{N})} \dots \dots \dots (13)$$

Where  $u$  is the frequency in  $x$  direction,  $u=0, 1, \dots, M-1$  and  $v$  is the frequency in  $y$  direction,  $v=0, 1, \dots, N-1$ .

If  $I$  is the image to be blurred,  $Ib$  is the resulted blur image, and it is assumed that the blur function  $G$  in the same size, this can be done by:

1. Transform image in frequency domain by using Fourier transform  $F$ .
2. Multiply the transform image by the Gaussian blurs function.
3. Applied inverse furrier transform of the blurred image in step 2.

### 9.The Entropy of the First Derivative (EFD) of image

This method depending on the first derivative of an image, as in the following formula [18]:

$$I_d(x, y) = \frac{\partial^2 I(x, y)}{\partial x \partial y} \dots \dots \dots (14)$$

Figure (3.2) shows the first derivative of high lightness and low lightness images. The entropy of the first derivative defined as follows [18]:

$$H(x) = \sum_k^n P(x_k) \log_2\left(\frac{1}{P(x_k)}\right) \dots \dots \dots (15)$$

Where  $\chi$  is a discrete random variable with possible outcomes  $x_1, x_2, \dots, x_n$ ,  $P(x_k)$  is the probability of the outcome  $x_k$ . The outcome is understood as a gray level in the lightness image and its probability is calculated by [18]:

$$P(x_k) = \frac{n_k}{N_t} \dots \dots \dots (16)$$

Where  $k = 1, 2, \dots, n$ ,  $n$  is the total number of possible lightness in the image,  $N_t$  is the total number of pixels, and  $n_k$  is the number of pixels that have lightness level  $x_k$ . The higher entropy value denotes a better contrast in image.

### 10.The results and discussion:

In this section, we study the reference and no reference metrics were applied to measure the quality of colored images distorted by Gaussian blurring. Firstly, we apply the two reference metrics (NMSE and SSIM) in the two color spaces were used (YCbCr and L\*u\*v\*) to measure the quality for 6 color images, the results was as in figures bellow, in figures (2) and (3) we see the results of the NMSE as a function of sigma (blurring factor), were in figures (4) and (5) we see the results of the SSIM as a function of sigma. Secondly, we apply the no reference metric EFD to assess the quality and comparing the results with the results of thereference metrics as in figures (6) and (7), were in tables (1) and (2) we see the amounts of correlation coefficients between the (EFD and NMSE) and (EFD and SSIM) respectively.



Figure (1): Images used in the study

## 11. Conclusions

Form these figures and tables we can note:

1. We find that In YCbCr and  $L^*u^*v^*$  color spaces, blurring affect the achromatic components (Y and L) more than chromatic components (CbCr and uv).
2. The amounts of NMSE and SSIM are increasing with the decreasing of sigma, in other word, NMSE and SSIM are increasing with the decreasing of blur, because sigma has an inversely relationship with blur.
3. In the EFD metric the quality decreasing directly with the decreasing of sigma, this means that, this metric has been succeeded to measure the quality.
4. From the amounts of the correlation coefficients we found that YCbCr color space is better to assess the quality than  $L^*u^*v^*$ .

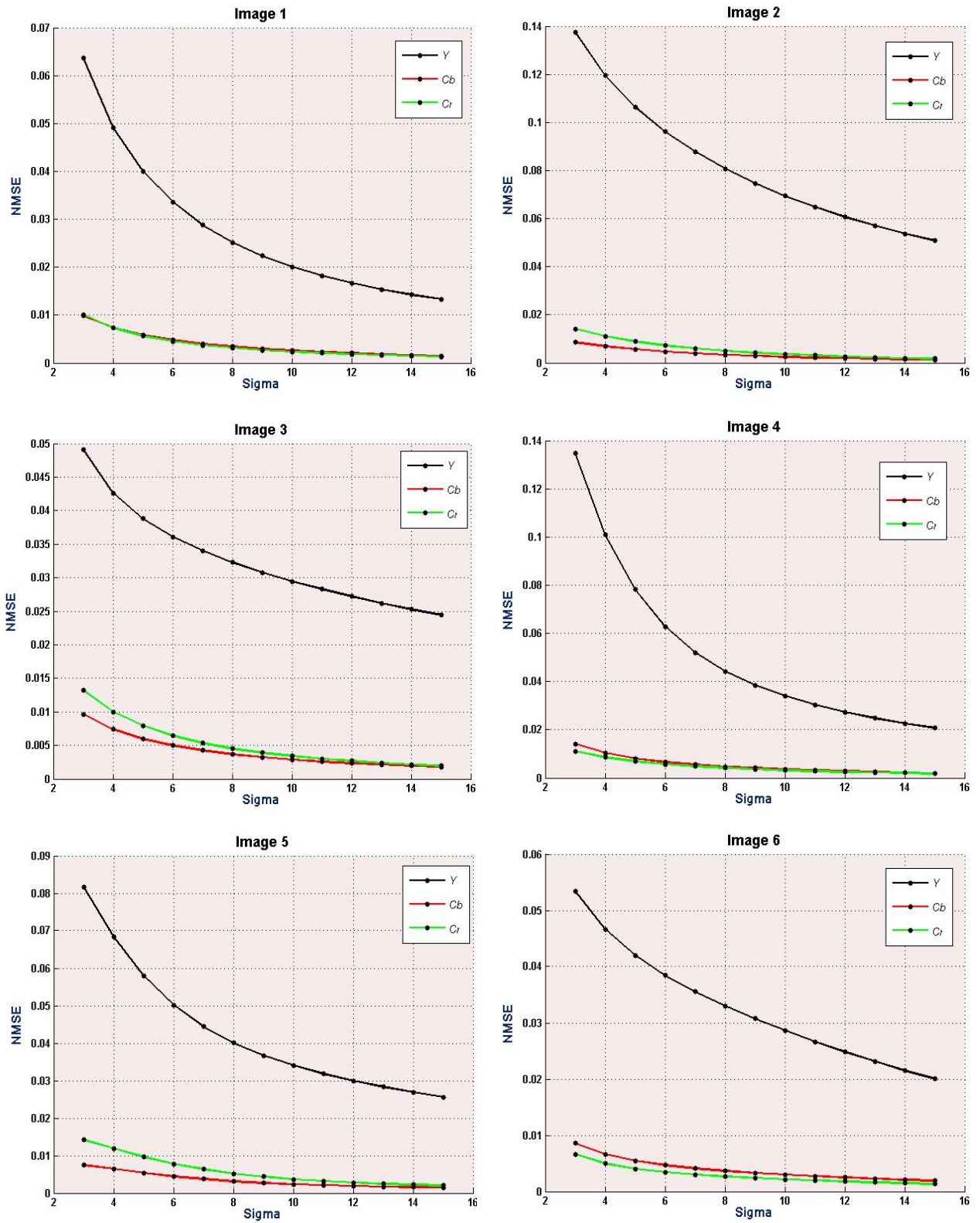

Figure (2) YCbCr components as a function of sigma in NMSE.

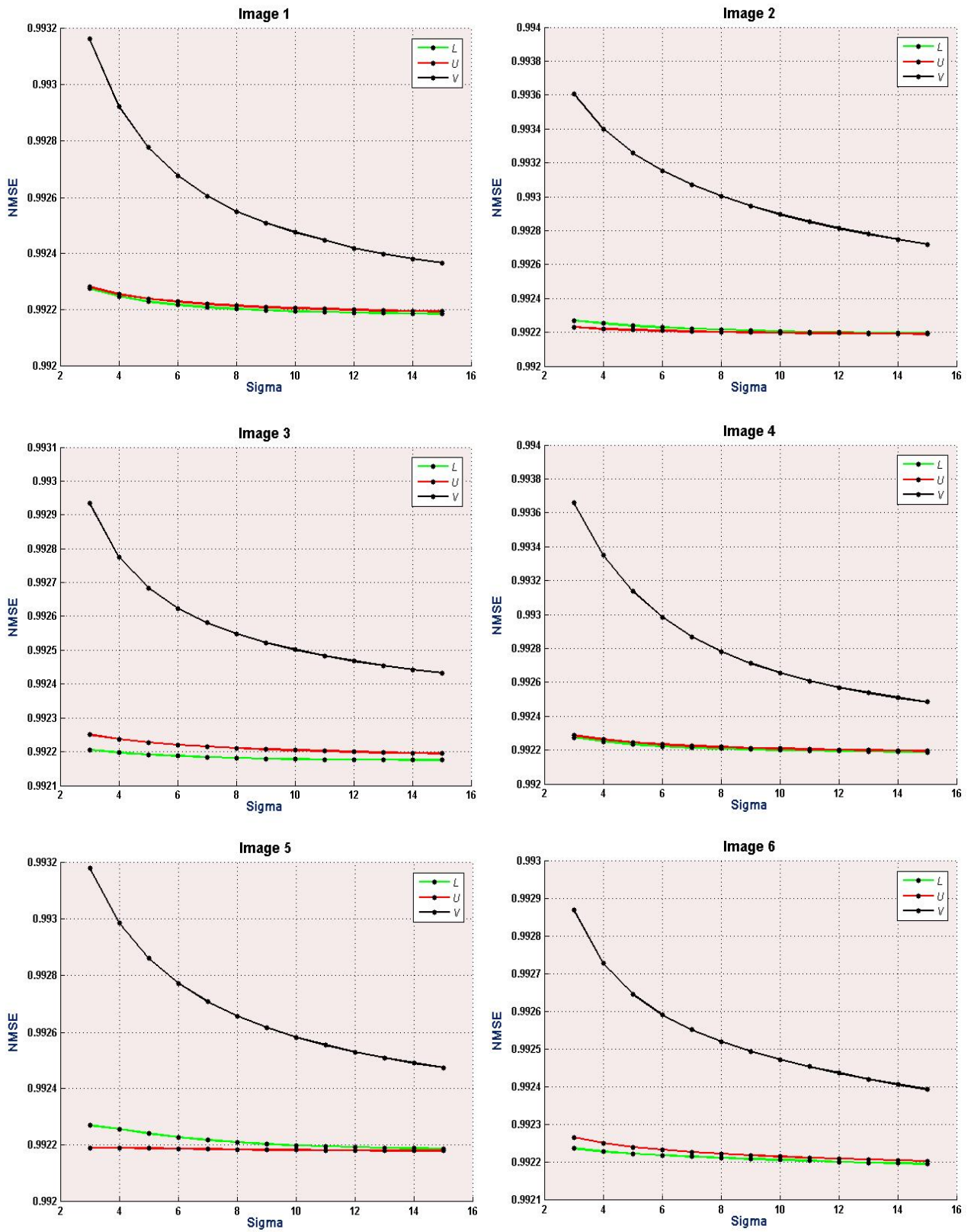

Figure (3) L\*U\*V\*components as a function of sigma in NMSE.

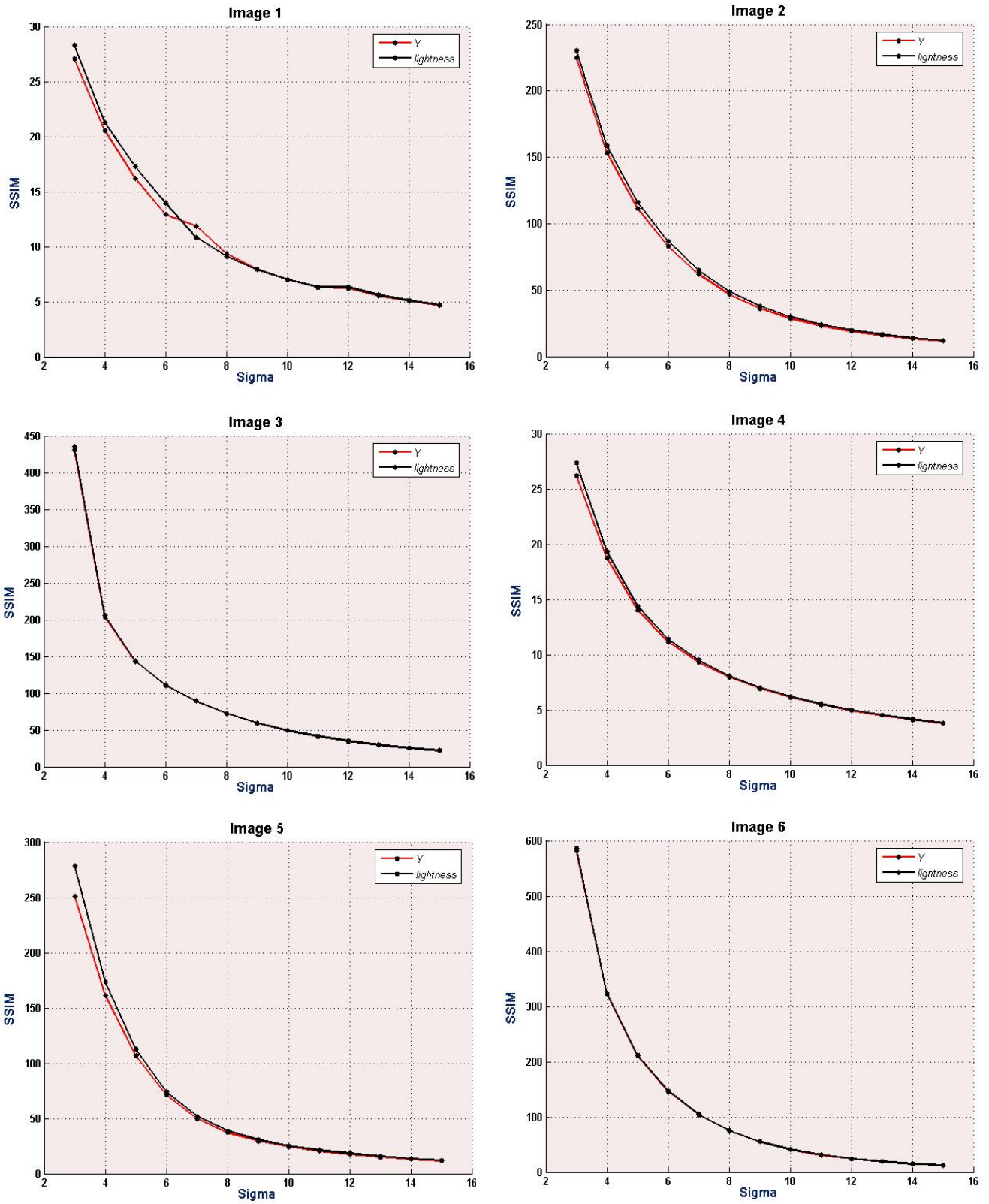

Figure (4) YCbCr components as a function of sigma in SSIM.



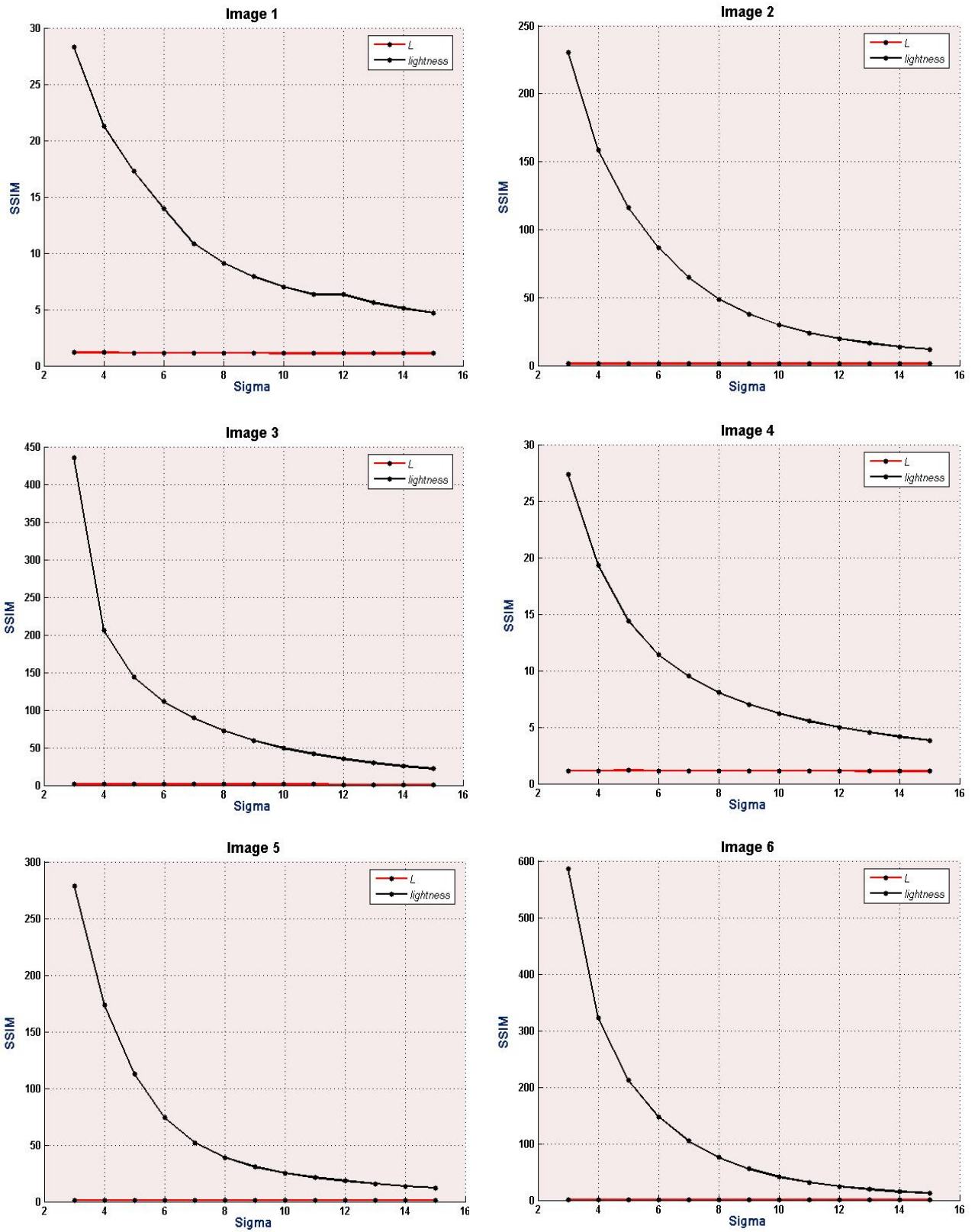

Figure (5)  $L \cdot u \cdot v$  components as a function of sigma in SSIM.

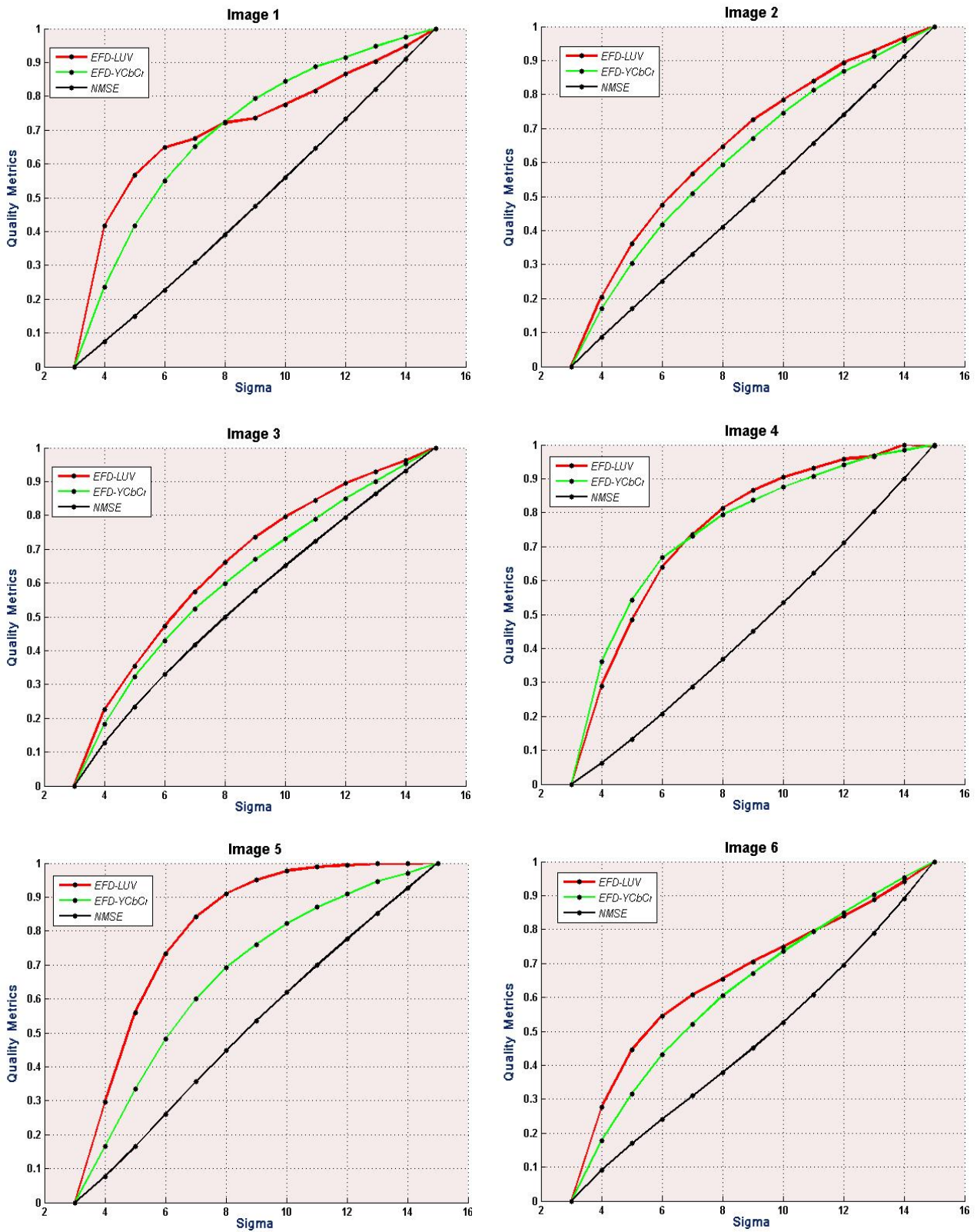

Figure (6) EFD metric in comparing with NMSE as a function of sigma in YCbCr and L\*u\*v\* color spaces.

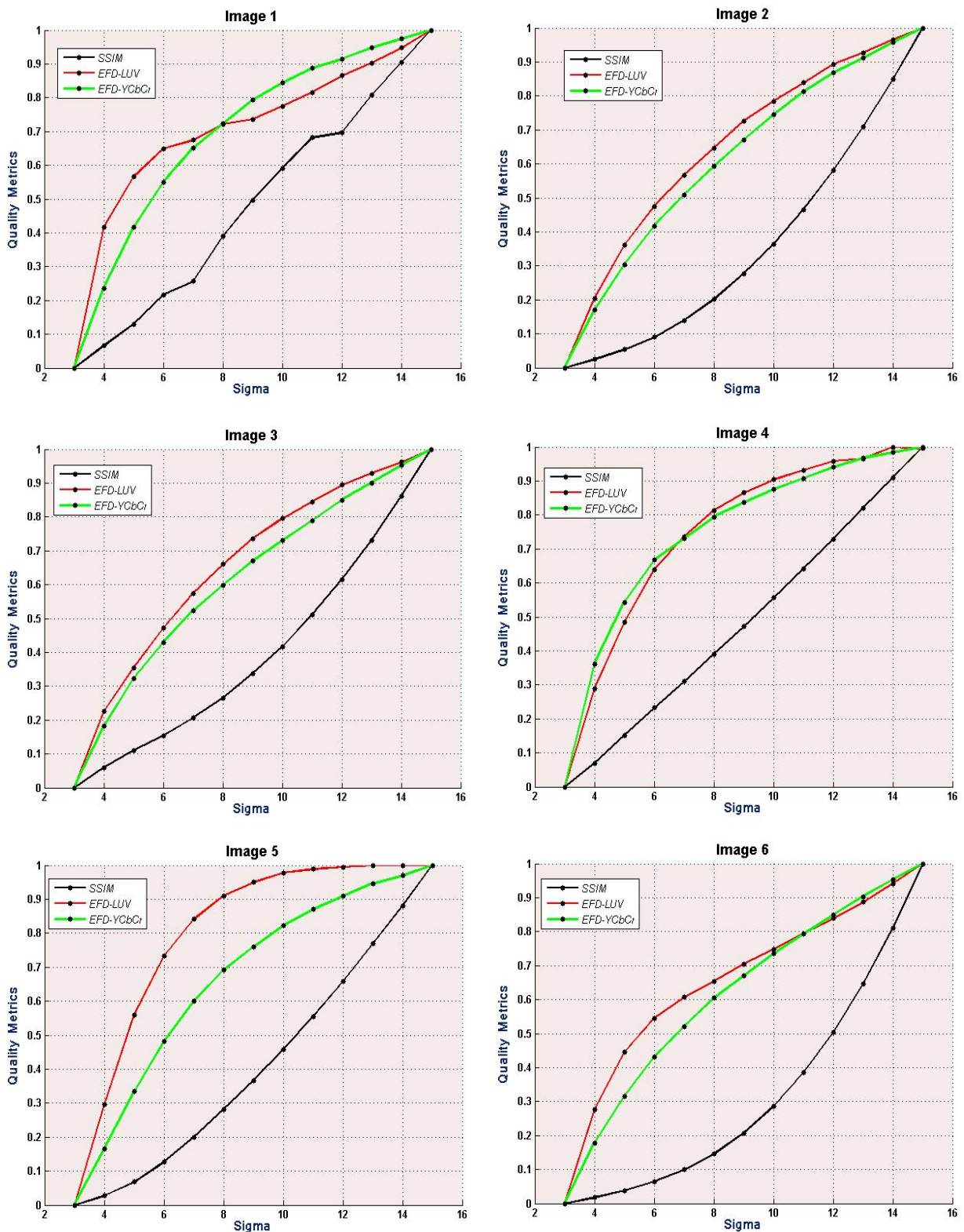

Figure (7)EFD metric in comparing with SSIM as a function of sigma in YCbCr and L\*u\*v\* color spaces..

Table (1): The best color space for quality estimation in EFD metric in comparing with NMSE according to correlation coefficients.

		Image1	Image 2	Image 3	Image 4	Image 5	Image 6	Average Cor.
Correlation coefficients of EFD	YCbCr	0.9245	0.9776	0.9825	0.8644	0.9632	0.9667	0.9464
	L*u*v*	0.8823	0.9620	0.9929	0.8695	0.8523	0.9372	0.9160

Table (2): The best color space for quality estimation in EFD metric in comparing with SSIM according to correlation coefficients.

		Image1	Image 2	Image 3	Image 4	Image 5	Image 6	Average Cor.
Correlation coefficients of EFD	YCbCr	0.9233	0.9026	0.9270	0.8765	0.8991	0.8643	0.8968
	L*u*v*	0.8744	0.8741	0.8981	0.8817	0.7484	0.8231	0.8499

### References:

1. Z.Jing, "No reference quality assessment of digital images", M.Eng., Shandong University, PH.D thesis, 2010.
2. F. Crete, T. Dolmiere, P. Ladret and M. Nicolas, "The Blur Effect: Perception and Estimation with a New No-Reference Perceptual Blur Metric", proc. of Human Vision and Electronic Imaging XII/Electronic Imaging 2007, SPIE Vol. 6492, San-Jose, CA, 2007.
3. X. Wang, B. Tian, and C. L. D. Shi, "Blind Image Quality Assessment for Measuring Image Blur", Image and Signal Processing, 2008. CISP '08. Congress on (Volume 1), 467 – 470.
4. R. Ferzli and L. J. Karam, "A No-Reference Objective Image Sharpness Metric Based on the Notion of Just Noticeable Blur (JNB)", IEEE Transactions On Image Processing, VOL. 18, NO. 4, APRIL 2009.
5. H. G. D. AL-Khuzai "Enhancement of color images captured at different lighting condition" PH.D thesis, Almustansiriah University, college of education, 2011.
6. A. Chetouani, A. Beghdadi, A. Bouzerdoum and M. Deriche,"A New Scheme for No Reference Image Quality Assessment" published in "3rd International Conference on Image Processing Theory, Tools and Applications, Istanbul, Turkey 2012 .
7. Y. A. Y. Al-Najjar, and D. C. Soong, "Comparison of Image Quality Assessment: PSNR, HVS, SSIM, UIQI", International Journal of Scientific & Engineering Research, Volume 3, Issue 8, August-2012 1 ISSN 2229-5518.
8. Z. Wang, and A. C. Bovik, "Why is Image Quality Assessment So Difficult?", IEEE ICASSP, 02 International Conference on Acoustics, Speech and Signal Processing, Orlando, Florida, USA, pp. 3313-3316, 2002.
9. Y. Horita, T. Miyata, P. I. Gunawan, T. Murai, and M. Ghanbari, "Evaluation Model Considering Static-temporal Quality Degradation and Human Memory for SSCQE Video Quality", in Proc. SPIE, Lugano, Switzerland, PP. 1601-1611, 2003.
10. X. Li, "Blind image quality assessment in Image Processing Proceedings", International Conference on, vol. 1, pp. I-449, 2002.
11. B. Girod, and A. B. Watson, "What's Wrong With Mean-Squared Error in Digital Images and Human Vision", pp. 207-220, 1993.

12. A. C. B. Zhou Wang, "A Universal Image Quality Index," IEEE Signal Processing Letters, vol. 9, pp. 81-84, 2002.
13. C. A. Poynton, "A technical introduction to digital video", Wiley, NY, 1996.
14. R. C. Gonzales, and R. E. Woods, "Digital Image Processing", second edition, Prentice Hall, 2002.
15. A. Ford and A. Roberts, "Color Space Conversions", 1998.
16. W. Z. Simoncelli, P. Local, "Phase Coherence and the Perception of Blur In Adv. Neural Information Processing Systems", pp. 786-792, 2003
17. D. J. Jabson, Z. Rahman, G. A. Woodell, "Retinex processing for automatic image enhancement," Journal of Electronic Imaging, Vol. 13(1), PP.100–110, January 2004.
18. T. T. Nguyen, X. D. Pham, D. Kim and J. W. Jeon, "Automatic Exposure Compensation for Line Detection Applications", IEEE International Conference on Multisensor Fusion and Integration for Intelligent Systems Seoul, Korea, 2008.

# STUDY THE OPTICAL PROPERTIES OF POLYVINYLPIRROLIDONE (PVP) DOPED WITH KBr

*Hussein Hakim*  
*Ahmed Hashim*  
*Ghaidaa Abdul-Hafidh*  
*Alyaa .H.A*  
*Saif Mohammed*  
Babylon University , Iraq

---

## Abstract

The pure polyvinylpyrrolidone (PVP) and (PVP-KBr) composite with different weight percentage of KBr were prepared using solution casting technique. The optical properties of randomly mixed system consisting of PVP and KBr powders were studied. The effect of KBr concentration on the optical properties of (PVP-KBr) composites have been investigated.

The experimental results show that the optical constants (Refractive index, Extinction coefficient, Real and Imaginary parts of the dielectric constant) showed clear changes with increasing the doping concentrations.

---

## 1-Introduction

The stability of polymer thin films on solid substrates is of great technological importance in applications ranging from protective coatings to paintings, semiconductor, and micro- and optoelectronic [1,2]. The polyvinylpyrrolidone (PVP) has good film-forming and adhesive behavior on many solid substrates and its formed films exhibit good optical quality (high transmission in visible range), and mechanical strength (easy processing) required for application [3]. In order to fulfill the requirements of polymer industry many develop usually blend polymers together in order to reach an optimum balance of properties. This paper deals with the effect of KBr on some optical properties of polyvinylpyrrolidone (PVP).

## 2.Experimental Part

The polymer was dissolved in distilled water by using magnetic stirrer in mixing process to get homogeneous solution at 90°C, then the solution was cooled at room temperature. The weight percentages of KBr are (0.5, 10 and 15) wt.% were added and mixed for 10 minutes to get more homogeneous solution, after which solution was transferred to clean glass petri dish of (5cm) in diameter placed on plate form. The dried film was then removed easily by using tweezers clamp. The polymer systems were evaluated spectrophotometrically by using UV/1800/Shimadzu spectrophotometer.

## 3.Results and Discussion

### 3-1 The transmission of composites

The transmission spectra of the (PVP-KBr) composites with different concentrations are presented in Fig 1. The composite films are transparent in the visible range. It is clear from Fig 1. as the concentration of the KBr component in the polymer composition decreases the transmission increases.

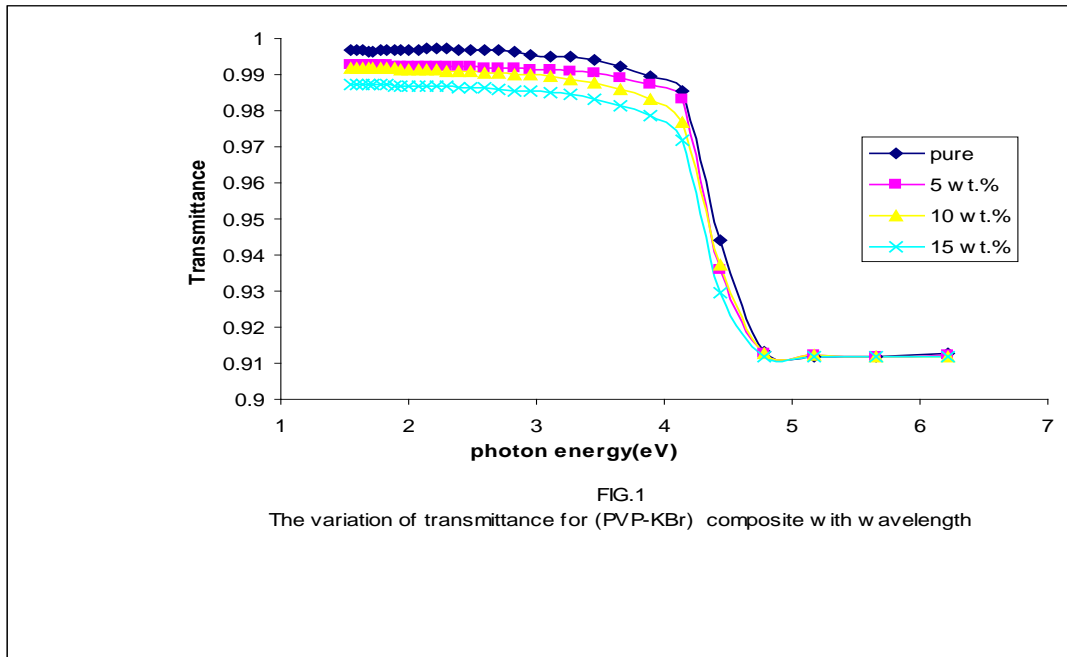

**3.2 The absorbance of composites**

Fig.2 shows the relationship between absorbance of (PVP-KBr) composite with wave length, from the figure it was appeared that the absorbance tends to decrease with the wavelength increasing. It clear From the Fig.2 that as the concentration of the KBr component in the polymer composition increase the absorbance increase this increasing may be refer to consist a new energy level between the valance band and conduction band .

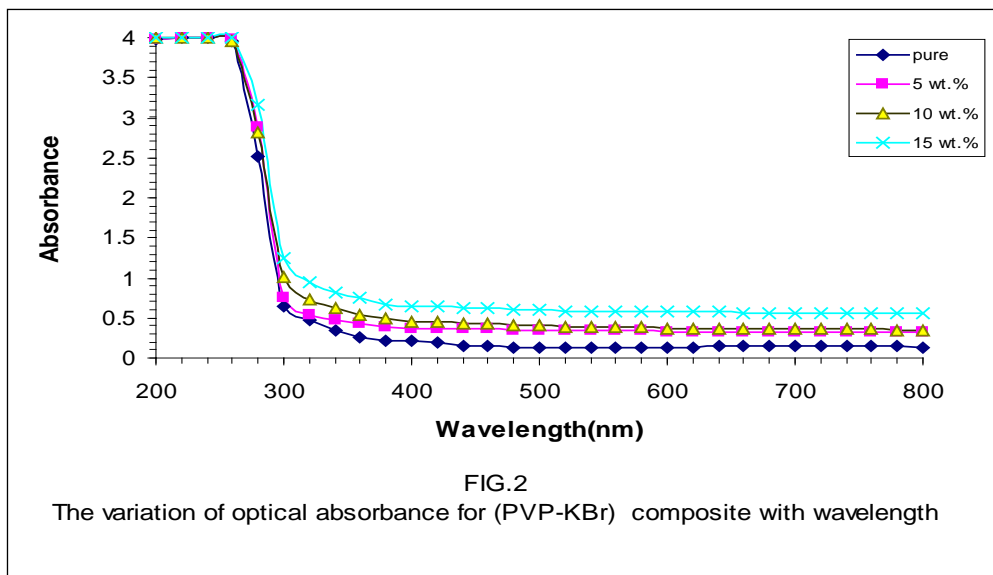

**3.3 The Absorption coefficient and energy gap of composite**

The absorption coefficient ( $\alpha$ ) was calculated in the fundamental absorption region from the following equation[4]:

$$\alpha = 2.303 \frac{A}{d} \dots\dots\dots(1)$$

Where : A is absorbance and (d) is the thickness of sample

Fig.3 shows the optical absorption spectrum of composite for different impurities quantities, it was found that the composite have a low absorption coefficient at a small

photon energy then increase at different rates dependence on the composite structure. The pure sample had low absorption coefficient this may be as a result of low crystallinity.

The optical energy gap  $E_g$  of the films has been determined from absorption coefficient data as a function of photon energy according to the non-direct transition model [5]:for higher values of absorption coefficient where the absorption is associated with interband transitions.

$$\alpha h\nu = B(h\nu - E_g)^2 \dots\dots\dots(2)$$

Where:  $h\nu$  = The energy of the incidence photon ,  $h$  = The Planck constant

$E_g$  = The optical energy band gap ,  $B$  = a constant known as the disorder parameter which is nearly independent of the photon energy.

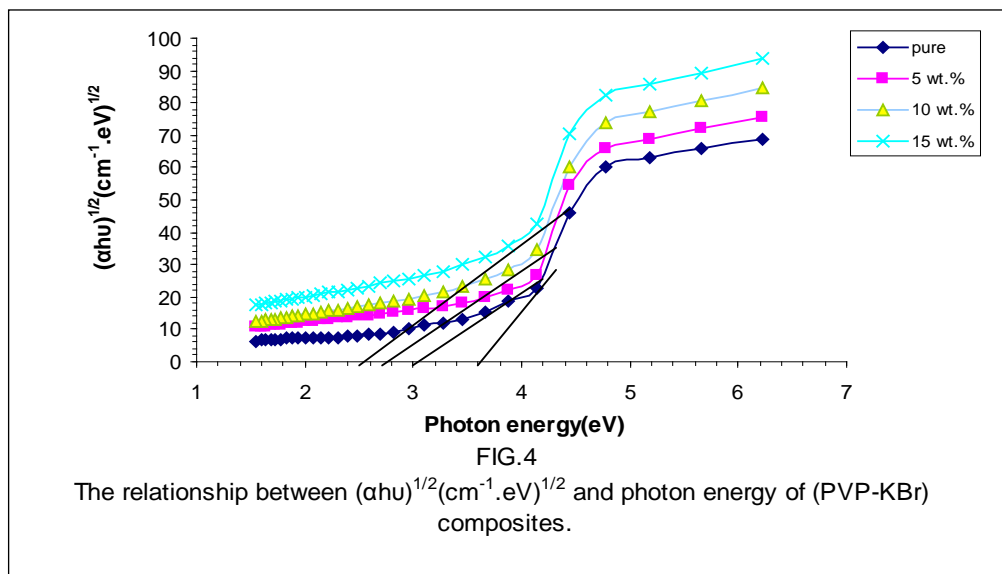
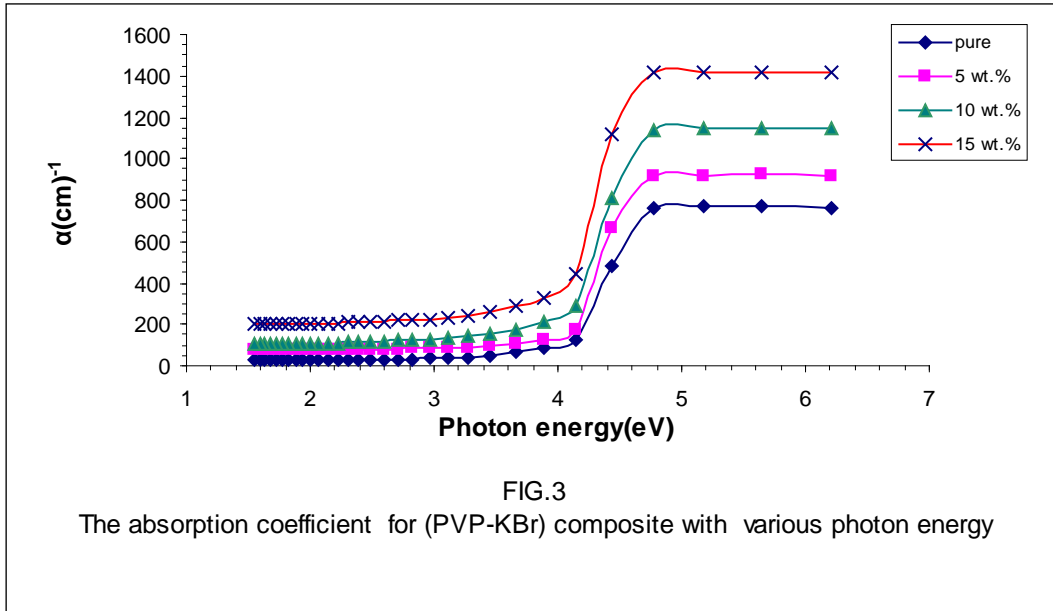

The indirect optical band gap can be evaluated from the linear plots of  $(\alpha h\nu)^{1/2}$  versus  $h\nu$  as illustrated in Fig.4 represented the indirect transition , the energy gap values dependence in general on the crystal structure of the composites and on the arrangement and distribution way of atoms in the crystal lattice . from Fig(4) the energy gap shift to lower energy with increasing the concentration of ( KBr ) compare with the pure (PVP).

**3-4 Refractive Index and Extinction Coefficient**

The refractive index (n) and extinction coefficient (k) are important parameters characterizing photonic materials. The refractive index (n) as a function of wavelength can



be determined from the reflection coefficient data R and the extinction coefficient K using equation:

$$n = \left( \frac{4R}{(1-R)^2} - K^2 \right)^{1/2} - \frac{(R+1)}{(R-1)} \dots\dots\dots(3)$$

Fig. 5 shows the variation of refractive index (n) of the composite with a given photon energy.

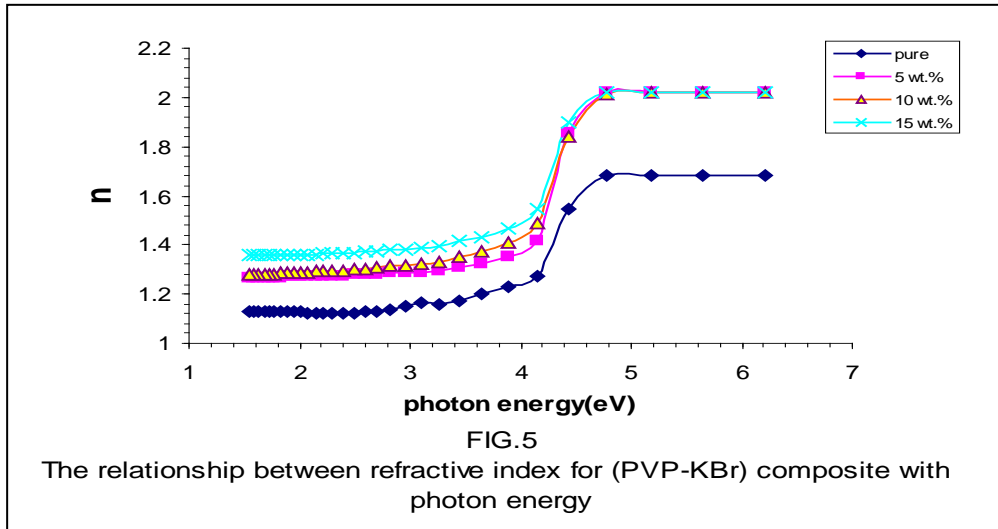

The extinction coefficient (k) was calculated using the following equation:

$$K = \alpha \lambda / 4\pi \dots\dots\dots(4)$$

Where (λ) is the wavelength and (α) the absorption coefficient .

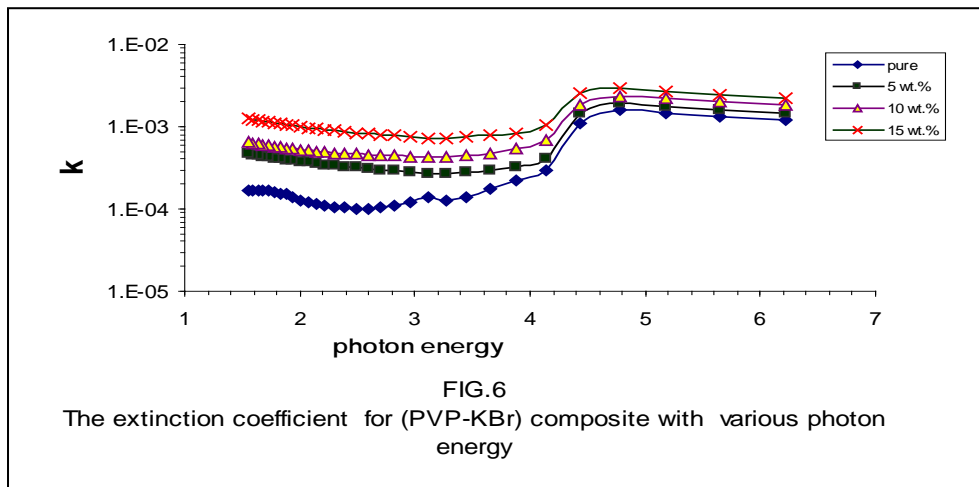

The fraction of light lost due to scattering increase with the concentration of KBr therefore the extinction coefficient increase as shown in Fig.6 .

**3.4 dielectric constant**

The dielectric constant of compound (ε) is divided into two parts real(ε<sub>1</sub>), and imaginary (ε<sub>2</sub>).The real parts of dielectric constant is associated with the term that shows how much will slow down the speed of light in the material and the imaginary parts shows how a dielectric absorbs energy from an electric field due to dipole motion . (ε<sub>1</sub> and ε<sub>2</sub>) can be calculated by using equations [6,7]:

$$\epsilon = \epsilon_1 - i \epsilon_2 \dots\dots\dots (5)$$

$$\epsilon_1 = n^2 - k^2 \dots\dots\dots (6)$$

$$\epsilon_2 = 2nk \dots\dots\dots (7)$$

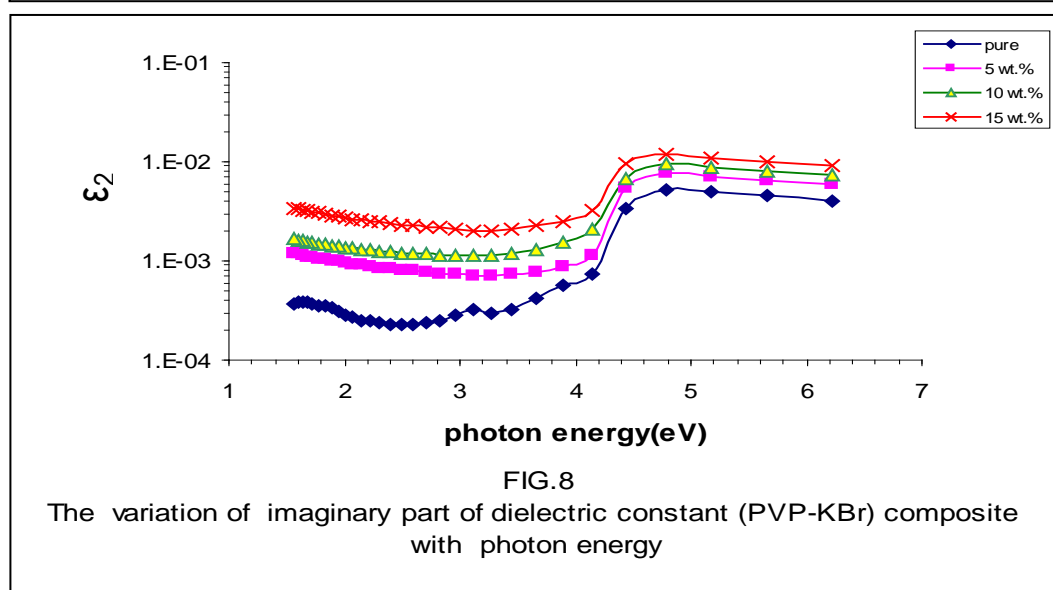
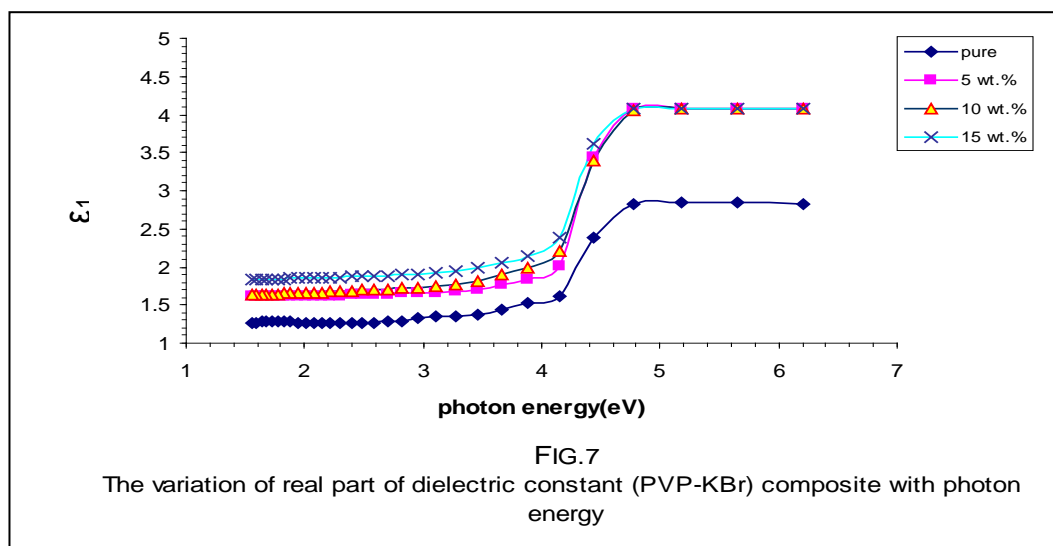

#### 4. Conclusions

Optical properties of PVP-KBr composite films were studied in the spectral region 200-800 nm. The composite showed high transmittance in the visible region making it suitable for using in window coatings. The interband transitions were found to be indirect type. The optical energy gap has been found to decrease with increasing the concentration of KBr. The refractive index has been found to increase with the increase the concentration of KBr. The real and imaginary dielectric constant increase with increasing the incident photon energy and the concentration of KBr. It will contribute to produce a new material that might potentially be used as an alternative or substitute material for many other applications.

#### References

1. Oslance, R.; Costa, A. C.; Composto, R. J. *Macromolecules* 2000, 33, P. 5505-5512.
2. Reiter, G. *Macromolecules* 1994, 27, p. 3046-3052.
3. Kothapalle, S.; Koramala, N. K.; V, Naresh, S. B. *Materials Sciences Application*, 2011, 2, p. 1688-1696.
4. BaoLi O., DuXin L., 2007, Preparation of Polystyrene/silica Nanocomposites by Radical Copolymerization of Styrene with Silica Macromonomer. *Sci. China. Ser. B-Chem.*, 50(3): p. 385-391.
5. New York, Plenum J. Tauc 1974. *Amorphous and Liquid Semiconductors* P.159.

6. Dr.Nahida, J.H. 2011, Study of the Optical Constants of the PMMA/PC Blends Eng. & Tech. Journal ,Vol.29, No.4.
7. R Tintu, K. Saurav, K.Sulakshna,Vpn.Nampoori,Pradhakrishnan and Sheenu thomas 2010..” Ge<sub>28</sub>Se<sub>60</sub>Sb<sub>12</sub> /PVA composite films for photonic application”. Journal of Non-Oxide Glasses Vol. 2, No 4, , p.167- 174,

# CONTRIBUTION TO OPTIMIZING THE PERFORMANCES OF ANAEROBIC REACTOR

*Abid Abdelilah, Assistant Prof.*

*Jellal Jamal Eddine, Prof.*

Mohammadia School of Engineering, Water Treatment Laboratory, Morocco

---

## Abstract

The Integrated System: Anaerobic Reactor – High Rate Algal Pond (AR-HRAP) is a new approach combining high-rate anaerobic/aerobic units for wastewater treatment.

In this combination, the anaerobic reactor plays a crucial role. Thus, control of hydrodynamics will both improve the design of such a structure and optimize its performance. According to several researchers, the hydrodynamic flow modeling is as important as the kinetic modeling of reactions.

This study aims to elaborate flow simulations for different residence times (1.5 d, 2 d, 3 d) in the anaerobic reactor, using software FLUENT.

This study has allowed us to have interesting results regarding hydrodynamic of anaerobic reactor.

---

**Keywords:** Hydrodynamic, simulation, anaerobic wastewater treatment

## Introduction:

The potential of wastewater in Morocco is very high: nearly 700 Mm<sup>3</sup> nowadays and 900Mm<sup>3</sup> expected in 2020. The climatic context of Morocco is characterized by recurring droughts which had lead to less than 1.000 m<sup>3</sup>/year of water per habitant. Therefore, wastewater treatment and reuse become a priority.

The success of any sanitation project is to be analysed in the context of limited funding capabilities, increasing resource depletion and greater environmental protection measures. The main requirements to be fulfilled by any chosen system are (El Hamouri, 2004):

- Low investment cost (avoiding equipment purchase and import)
- Low land area requirement,
- Simplicity of construction and operation,
- Minimization of sludge production,
- Transformation of organic matter into useful energy,
- Recycling of nutrients for crop production,
- Water conservation through agricultural reuse and/or urban purposes,
- Minimization of wastewater collection and conveying costs.

A research project aimed at the development of adapted technologies for wastewater treatment and reuse in small rural communities was initiated at the *Institut Agronomique et Vétérinaire Hassan II* (IAV) of Rabat. A new approach combining high-rate anaerobic/aerobic units is used to treat a daily flow of 63 m<sup>3</sup>.

In the field of wastewater treatment, the study of reactor performance requires mastery modeling of the main factors that govern the functioning of these reactors. As such, the hydrodynamic flow modeling is as important as the kinetic modeling of reactions. (Villermaux, 1993).

The anaerobic reactor is a very important element in a sewage treatment plant system integrated type: Anaerobic Reactor - High Rate Algal Pond (RA-HRAP)

The proper functioning of RA directly affects the quality of treatment in the HRAP. Control of hydrodynamic will both improve the design of such a structure and optimize its performance.

This study aims to simulate the flow for different residence times (1.5 d, 2 d, 3 d) in the anaerobic reactor.

## I- Materials and methods

### I.1- The two-step upflow anaerobic reactor

The city of Rabat, capital of Morocco, is located in the North-West of the country (latitude 30°03' N, longitude 6°46' W). Its altitude is 73 m above sea level. The average temperature in the site is 14°C in the cold season and 24°C in the hot season.

The plant occupies 1,200 m<sup>2</sup> and receives a daily average flow of 63 m<sup>3</sup>. It includes a preliminary treatment (screening and grid removal) followed by a TSUAR (Two-Step Upflow Anaerobic Reactor), for pre-treatment, and then by a post-treatment line, which includes a HRAP (High Rate Algae Pond) flanked with one MP (Maturation Pond) (Figure 1).

Figure 2 shows the pre-treatment configuration at the IAV plant.

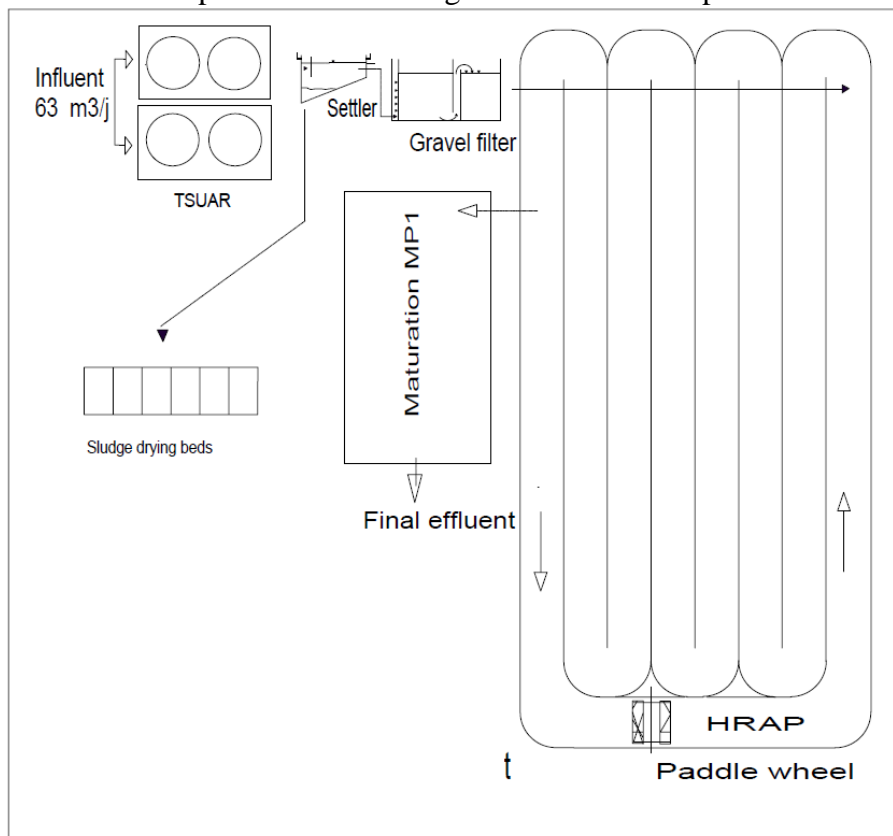
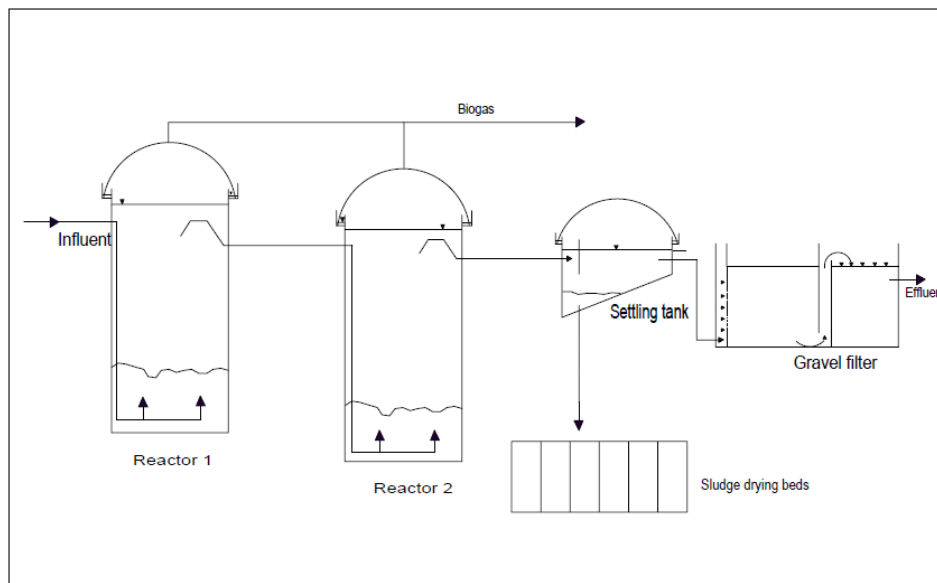

Fig. 1: Layout of the IAV treatment plant



**Fig. 2: The pre-treatment unit of the IAV treatment plant**

Anaerobic unit located upstream of the station consists of two similar paralleled channels. Each channel consists of two anaerobic reactors in series (R1 & R2) followed by an outer separator (D). The set { R1 + R2 + D } is called "two-phase anaerobic system" (SADP)

Dimensions and key operational parameters are presented in Table 1 . These reactors are completely covered and each provided with a biogas collection system.

In both reactors, upflow velocity was maintained in the range of 0,1 to 0,6 m h<sup>-1</sup> depending on the admitted flow, which varies during the day.

**Table 1: Dimensions and operating parameters for reactors R1 and R2 of the TSUAR**

	Reactor R <sub>1</sub>	Reactor R <sub>2</sub>
Depth (m)	5,30	5,00
Area (m <sup>2</sup> )	7,06	7,06
Diameter (m)	3,0	3,0
Volume (m <sup>3</sup> )	33	31
Average HRT (h)	24	23
Average solid retention time (d)	32	32
Over flow (m h <sup>-1</sup> )	0,1 – 0,6	0,1 – 0,6
Number of inlets	2	2
Number of outlets	1	1
Average HLR (kg COD m <sup>-3</sup> d <sup>-1</sup> )	0,76	0,40

HLR: hydraulic loading rate

Source: El Hamouri, 2004

## I.2- Introducing FLUENT

To perform our simulations, we used the FLUENT software.

Like any CFD software , it is composed of three elements: the pre- processor, solver and post- processor.

The definition of the problem is done using the preprocessor GAMBIT . It allows to represent the geometry of the system , defining the type of limits on domain boundaries conditions, specify the type of material ( liquid or solid ) . It also provides the ability to discretize the field , offering several algorithms following mesh geometry.

The numerical solver is used to define the operating conditions ( gravity , pressure) of the simulation and the specification of the boundary conditions. Finally, it allows us to choose the iterative process, in particular by proposing several numerical schemes for spatial and temporal discretization , and for coupling the velocity and pressure . It also provides an interface to monitor at any time the status of calculations.

The post-processor allows to visualize the geometry and meshing of the domain, but also to display the results. It is thus possible to display the velocity vector field, the pressure field, the Reynolds and all other quantities calculated on a segment, a section of the area or over the entire volume. It also provides the ability to draw curves and visualize streamlines or particle trajectory.

Fluent software widely used in a variety of areas, offers a sophisticated interface that facilitates its use. These reasons have motivated our choice to use this software.

## II- Theoretical approach:

### II.1- Flow characteristics

Data flow and medium properties are summarized in the following tables:

**Tab. 2 : data flow**

Residence time (d)	Flow rates (l/s)	Inlet average speeds (m/s)
1,5	0,24	0,030
2	0,18	0,023
3	0,12	0,015

**Tab. 3 : medium properties**

Medium	wastewater
Density (kg/m <sup>3</sup> )	998
Kinematic viscosity (m <sup>2</sup> s <sup>-1</sup> )	10 <sup>-6</sup>

The Reynolds number of the flow is expressed by :  $Re = \frac{\rho V L}{\mu}$

V: The flow velocity at infinity (output speed),

L: The characteristic length of the RA (RA diameter),

$\rho$ : The density of the fluid,

$\mu$ : The dynamic viscosity of the medium.

This number defines the ratio of inertial forces to viscous forces and thus characterizes the behavior of the fluid for a given geometry.

The values of Reynolds number corresponding to different residence times are shown in the table below:

**Tab. 4 : values of Reynolds number for different residence times**

Residence time (d)	Average exit speeds (m/s)	Re
1,5	0,030	1210
2	0,023	928
3	0,015	606

These values give to the flow laminar character which increases with residence time. To verify that there is no phenomenon of tourbillon we use the following expression of Reynolds number:

$$Re = \frac{nL^2}{\vartheta}$$

$\vartheta$ : kinematic viscosity m<sup>3</sup>/s. (1,0087.10<sup>-6</sup> m<sup>3</sup>/s)

n: rotating speed of the fluid (t/s).

From the Reynolds number values previously obtained, the rotational speed of the fluid for different residence times are deduced :

**Tab. 5: Rotational speed of the fluid for different residence times**

Residence time (d)	Re	n (t/s)	n (t/min)
1,5	1210	0,00021	0,0127
2	928	0,00016	0,0097
3	606	0,00011	0,0063

The results show that there is no tourbillon phenomena.

The figure below outlines the boundaries of the domain, the configuration of the input and the output.

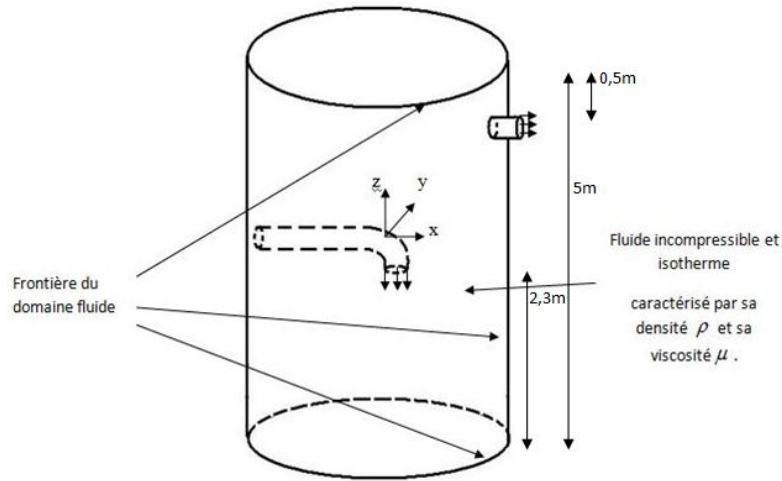

**Fig. 3**

**II.2- Setting equations**

To study the flow, we will use the Navier-Stokes equations in cylindrical coordinates for a potential flow given the geometry of the reactor:

This is an irrotational flow, and  $\vec{V}$  derives from a potential gradient  $\vec{V} = \nabla\varphi$   
 $\varphi$ : Velocity potential

Whence:  $\vec{\omega} = \text{rot}\vec{V} = \nabla \times \vec{V}$

According to the continuity equation :  $\text{div}\vec{V} = 0$

So :  $\text{div}(\nabla\varphi) = 0 \longrightarrow \nabla^2\varphi = 0 \longrightarrow \Delta\varphi = 0$

Whence the Laplace equation in cylindrical coordinates (r, θ, z):

$$\Delta\varphi = \frac{\partial^2\varphi}{\partial r^2} + \frac{1}{r} \frac{\partial\varphi}{\partial r} + \frac{\partial^2\varphi}{\partial\theta^2} + \frac{\partial^2\varphi}{\partial z^2} = 0$$

The flow in the RA is plane, as shown in the figure below:

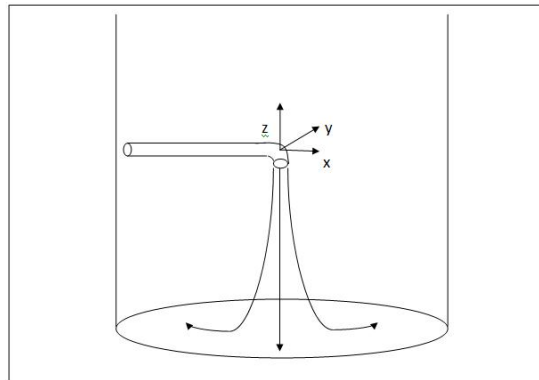



So our problem boils down to a source uniformly distributed over the OZ axis.

If Q is the volume flow per unit width:

$$\begin{aligned} \text{rot}\vec{V} = 0 &\longrightarrow \begin{cases} V_\theta = 0 \\ V_r = f(r) \\ V_r = Q/2\pi r \end{cases} \\ dQ = r.d\theta.V_r &\longrightarrow \end{aligned} \quad (1)$$

$$\begin{aligned} \nabla\varphi = \vec{V} &\longrightarrow \begin{cases} \frac{\partial\varphi}{\partial r} = V_r \\ \frac{\partial\varphi}{\partial\theta} = 0 \\ \frac{\partial\varphi}{\partial z} = 0 \end{cases} \\ \frac{\partial\varphi}{\partial r} = Q/2\pi r &\longrightarrow \varphi = \frac{Q}{2\pi} \ln r \end{aligned}$$

$$\text{So: } \text{div}\vec{V} = \frac{V_r}{r} + \frac{\partial V_r}{\partial r} + \frac{1}{r} \cdot \frac{\partial V_\theta}{\partial\theta} = 0$$

$$\begin{aligned} \text{Thus there exists } \psi \text{ such that: } &\begin{cases} \frac{1}{r} \cdot \frac{\partial\psi}{\partial\theta} = V_r = Q/2\pi r \\ \frac{\partial\psi}{\partial r} = -V_\theta = 0 \end{cases} \\ \psi = \frac{Q}{2\pi} \theta & \end{aligned}$$

$$f(z) = \varphi + i\psi$$

$$f(z) = \frac{Q}{2\pi} (\ln r + i\theta)$$

Can be defined in the complex plane a "Potential Complex"  $f(z)$  such that:  $f(z)$  is an analytical function that depends only on the complex variable  $z = x + iy$ .

$$z = re^{i\theta} \longrightarrow \ln z = \ln r + i\theta \longrightarrow f(z) = \frac{Q}{2\pi} \ln z$$

$$z = x + iy \longrightarrow \frac{df(z)}{dz} = \frac{Q}{2\pi} \frac{1}{(x+iy)} = \frac{Q}{2\pi} \cdot \frac{x-iy}{(x^2-y^2)} = V_x - iV_y$$

$$V_x = \frac{Q}{2\pi} \frac{x}{x^2+y^2} \quad \text{and} \quad V_y = \frac{Q}{2\pi}$$

$$z = re^{i\theta} \longrightarrow f(z) = \frac{Q}{2\pi} \ln z = \frac{Q}{2\pi} \ln(\sqrt{x^2+y^2} e^{i\theta})$$

$$\longrightarrow f(z) = \frac{Q}{2\pi} (\ln(\sqrt{x^2+y^2}) + i\theta)$$

$$f(z) = \varphi + i\psi \longrightarrow \varphi = \frac{Q}{2\pi} \ln(\sqrt{x^2+y^2}) \quad \text{and} \quad \Psi = \frac{Q}{2\pi} \arctan\left(\frac{y}{x}\right)$$

$$V_x = \frac{\partial\varphi}{\partial x} = \frac{Q}{2\pi} \frac{x}{x^2+y^2} \longrightarrow \frac{dx}{V_x} = \frac{dy}{V_y},$$

$$V_y = \frac{\partial\varphi}{\partial y} = \frac{Q}{2\pi} \frac{y}{x^2+y^2} \longrightarrow \frac{dx}{x} = \frac{dy}{y},$$

$$\text{Whence the stream function: } \Psi = \frac{Q}{2\pi} \arctan\left(\frac{y}{x}\right)$$

$$\text{And the equation of the current lines: } \frac{y}{x} = C$$

### III- Simulation

#### III.1- Meshing

The meshing structure is studied in the following order: Meshing surfaces, meshing volume controls and verification of meshes.

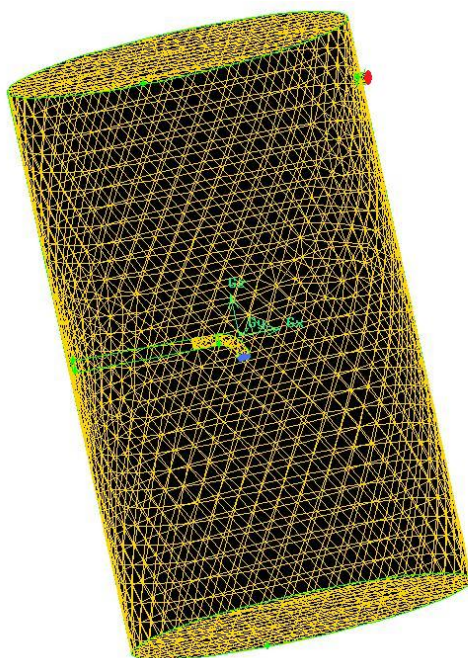

Fig. 4 : Meshing with Gambit

#### III.2- Boundary conditions

To perform the simulation, certain boundary conditions must be determined in accordance with the data of the software.

These conditions concern exit, sides and bottom of the RA.

Tab. 6: Boundary conditions

component	Boundary conditions (FLUENT)
entry	Velocity inlet
output	Out flow
background	Wall
free surface	Symmetry
walls	Wall
Elbow + pipe	Wall

#### III.3- Data bases for Fluent

Simulation is performed for three different residence times: 1.5 d - 2d - 3d.

Inlet flow rates and average speeds corresponding to residence times are summarized in the following table:

Tab. 7: Simulation data

Hydraulic Retention Time (HRT) (d)	Inlet flow rates (l/s)	Inlet average speeds (m/s)
1,5	0,24	0,030
2	0,18	0,023
3	0,12	0,015

We consider for the resolution a single phase, the wastewater.

### IV- Results

#### Convergence

To ensure the convergence of the calculations, we help two visual criteria. The first is to look at the curves of the residues, the second is to follow the evolution of the velocity fields during the iterations. When not changing, it means that the calculation has converged.

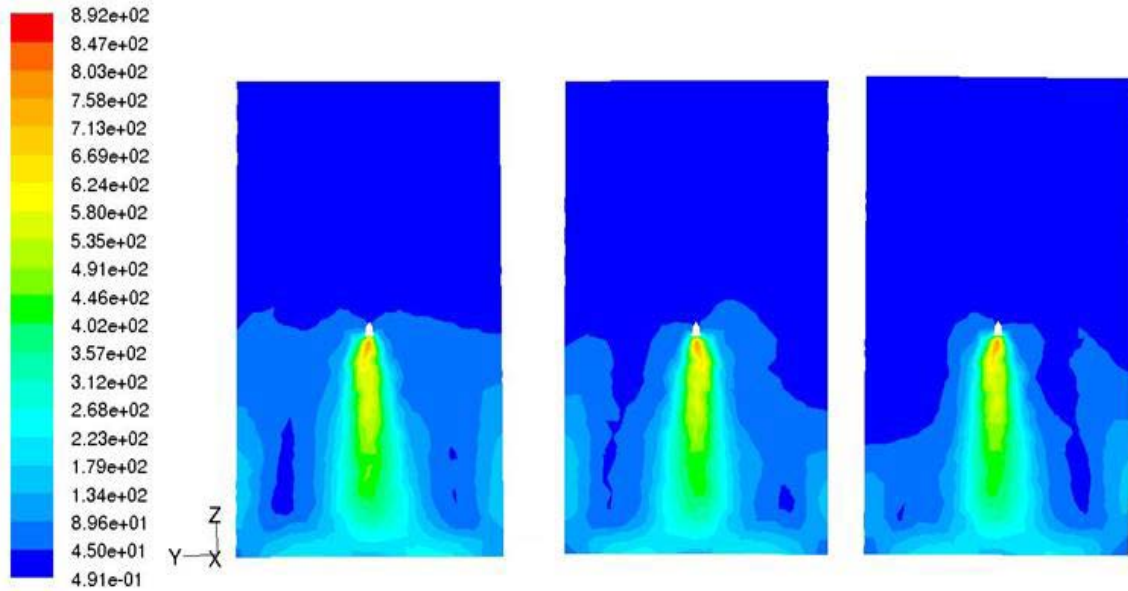
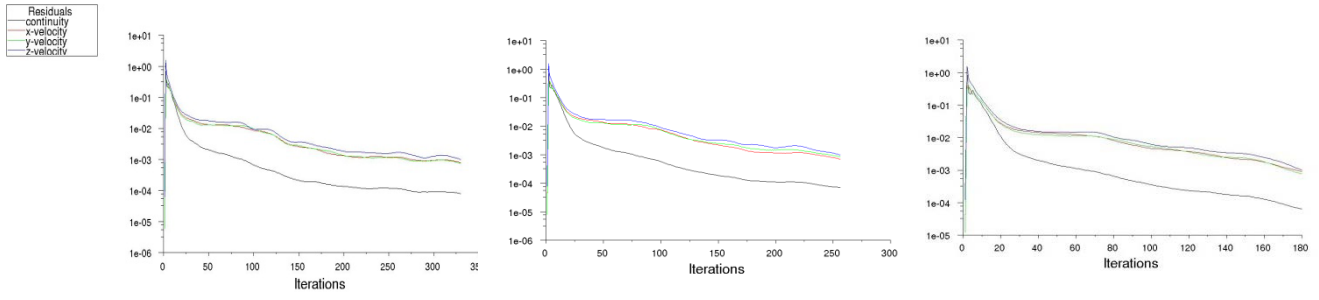

Contours of cell Reynolds Number  
Velocity vectors

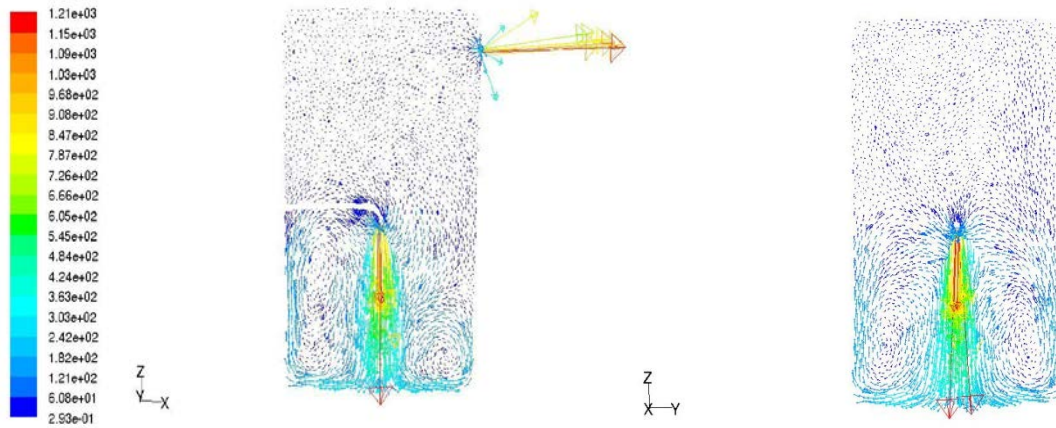

Velocity vectors colored by cell Reynolds Number for HRT = 1.5 d

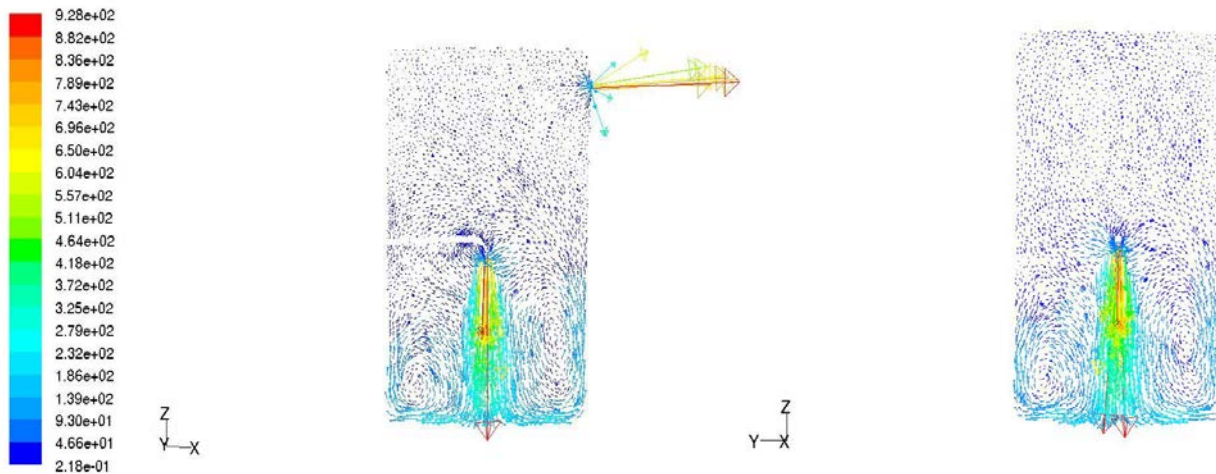

Velocity vectors colored by cell Reynolds Number for HRT = 2 d

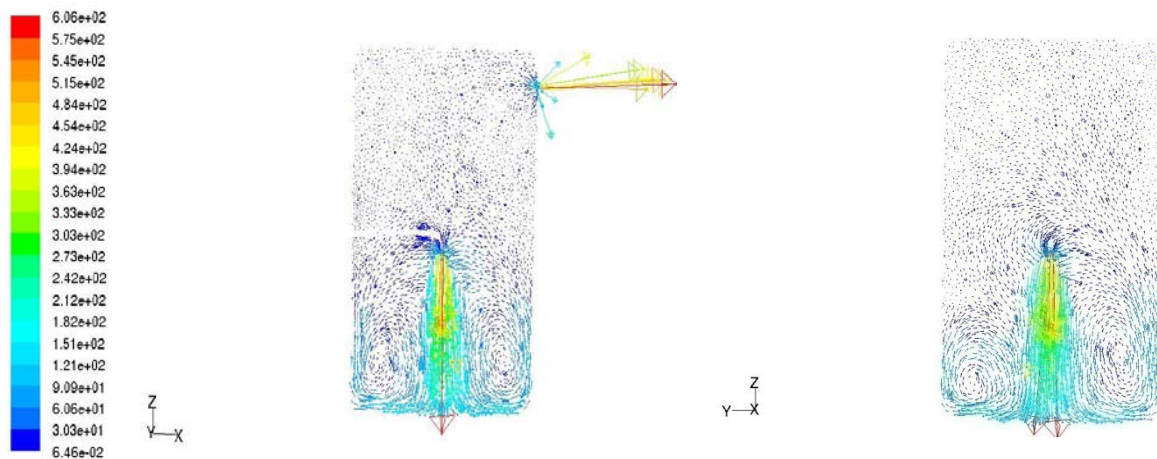

Velocity vectors colored by cell Reynolds Number for HRT = 3 d

## V- Discussion

The flow simulation showed:

- A turbulence at the inlet and outlet leading to a peak Reynolds number.
- A symmetry of the flow relative to the plane (O, x, z).
- Speeds greater near the walls.
- The phenomenon of the boundary layer near the walls.
- A separation of the boundary layer.
- A piston flow above the inlet.
- The influence of the residence time on the turbulence of the flow: when the residence time increases, the turbulent nature diminishes.

The simulation also revealed some shortcomings related to the design of RA:

- Presence of stagnant zones and dead zones

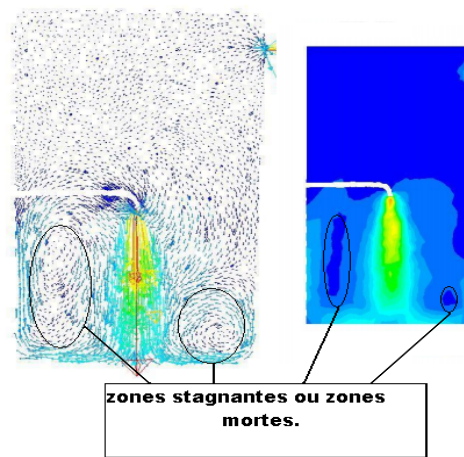

- Greater velocities at the bottom wall of the reactor (zone where the sludge is located) can lead to the phenomenon of separation of the boundary layer velocity at said wall. There is therefore a risk of bubbling of the sludge that it is at the bottom of the reactor

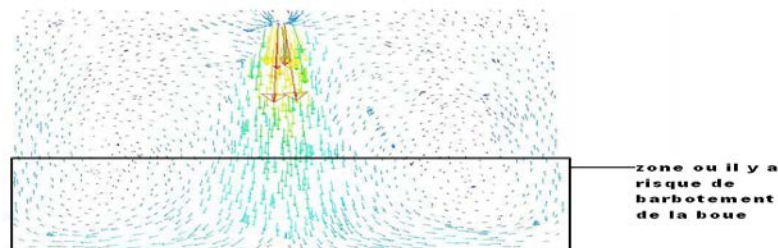

- A fairly random stratification of Reynolds number below the entrance reveals a real flow away from the plug flow coveted for optimizing the operation of such reactors.

### Conclusion:

This study has allowed us to have interesting results regarding hydrodynamic of anaerobic reactor. It was helped us, among other things, to update the existence of dysfunctions that certainly affect the performance of the reactor and are directly related to the choice of design parameters such as the position and geometry of the wastewater entry or inlet and outlet velocities.

### References:

- El Hamouri B., Jellal J., Outabiht H., Nebri B., Khallayoune K., Benkerroum A., Hajli A. & Firadi R., The performances of a High-Rate algal Pond in the Moroccan climate. *Water Science & Technology* 31, (12), 67-74, 1995.
- El Hamouri B., Réacteur Anaérobie et Chenal à Haut Rendement Pour l'épuration des eaux usées des petites communautés. IAV, Maroc, 2004.
- El Hafiane F. and El Hamouri B. Performances d'un système anaérobie à deux phases dans le traitement des eaux usées domestiques sous climat Méditerranéen. *Actes IAV Hassan II*, 22 (3) 133-141, 2002.
- Elmitwalli AT, Zandvoort MH, Zeeman G, Bruning H & Lettinga G. Low temperature treatment of domestic sewage in up-flow anaerobic sludge blanket and anaerobic hybrid reactors. *Wat Sci Tech* 39 (5): 177-185, 1999.
- Elmitwalli AT, Kim LT, Zeeman G & Lettinga G. Treatment of domestic sewage in a two-step anaerobic filter /anaerobic hybrid system at low temperature. *Wat Res* 36: 2225-2232, 2002.

- Haskoning (1994). Royal Dutch Consulting Engineers and Architects. Anaerobic treatment of domestic wastewater under tropical conditions. DECOM manual.
- Hulshoff Pol L, Euler H, Eitner A & Grohganz TBW. State of the art sector review. Anaerobic Trends. WQI July/August, 31-33, 1997.
- Lettinga G. Treatment of raw sewage under tropical conditions. Design of anaerobic processes for the treatment of industrial and municipal wastes. Volume 7. Lancaster, Pennsylvania, USA, 1992
- Lettinga G., Field J., Van Lier J., Zeeman G. & Hulshoff POL.L.W.. Advanced anaerobic wastewater treatment in the near future. Wat. Sci. Technol. 35 (10), 5-12, 1997.
- Mc Carty PL The development of anaerobic treatment and its future. Proceedings Farewell symposium Gatze Lettinga, March, Wageningen., 2001.
- McCarty P.L. Anaerobic wastewater fundamentals. Public works, 95, 10, pp 123-126, 1964.
- Moletta R.. Contrôle et conduite des digesteurs anaérobies. Revue des Sciences de l'Eau 2 : 265-293, 1989.
- Niyongabo Henri. Intégration des enjeux social et quantitative pour la maîtrise de l'assainissement liquide en Afrique Tropicale : Application à la ville de Bujumbura. Thèse de doctorat, Université de Liège, 293p., 2006.
- Pastor R. & Tobella J. Added value knowledge report AVKR 8, MED-REUNET II, 2005.
- Van Haandel A. and Lettinga G. (1994). Anaerobic Sewage Treatment in: A Practical Guide for Regions with a Hot Climate. Wiley & Sons, Chichester, UK, 1994.
- Van Lier JB & Lettinga G. Appropriate technologies for effective management of industrial and domestic wastewaters: the decentralized approach. Wat Sci Tech 40 (7): 1-18, 1999.
- Van Lier JB, Tilche A, Arhring BK, Macarie H, Molletta R, Dohanyos M, Hulshoff Pol LW, Lens P & Verstraete W. New perspectives in anaerobic digestion. Wat Sci Tech 43 (1): 1-18, 2001.
- Villiermaux, J., Eds. Génie de la réaction chimique - Conception et fonctionnement des réacteurs. Broché, Paris, 1993.

# ASPECTS ABOUT THE PROPERTIES OF A BAINITIC DUAL-PHASE S.G. CAST IRON

*Ioan Milosan, PhD*

Professor, Transilvania University of Brasov, Romania

---

## Abstract:

The paper presents a study about the influence of some heat treatment parameters of austempering and annealing with tempering over the structure and values of hardness, tensile strength, elongation and impact strength of a low alloyed S.G. cast iron. It is pointed out the influence of some factors (the temperature and the holding time at the isothermal level) on the phase transformation and properties in the studied cast iron.

---

**Keywords:** Materials science, cast iron, heat treatment, dual-phases

## Introduction:

Over the last few years, a number of thermal processes have been developed to modify the matrix structure and thus the properties of ductile cast iron.

Earlier papers (Simon, 1996) have shown what a major importance represents the studies about the bainitic S.G. cast irons obtained by heat treatment, especially the isothermal hardening (Batra et. al., 2003). Being a variante of the classical isothermal heat treatment, the Dual-Phase bainitic heat treatment is using a certain type of S.G. cast iron, which is characteristic by a large and low  $A_s$ - $A_f$  interval of temperatures.

After this heat treatment, the structure is composed of ferrite and bainite (in the case of cast iron, the bainite mean a structure composed of bainitic ferrite and carbon enriched austenite). The structures confer to material high values for the impact strength even at the low temperature (Eric et. al., 2006).

The studied materials are Ni-Cr low-alloy bainitic S.G. cast iron obtained by two heat treatments: the classical isothermal austempering heat treatment and the "Dual-Phase" bainitic heat treatment.

## Research objectives

This research has a number of objectives which can be started as follows:

1. To determine the mechanical properties: hardness (HB), tensile strength ( $R_m$ ), elongation (A) and impact strength (KCU) at the isothermal temperature.
2. Identify the effect of heat treatment over the structure and properties.

## Materials

The studied cast iron has the following chemical composition (% in weight): 3.61% C; 2.67% Si; 0.53 % Mn; 0.011%P; 0.005%S; 0.06%Mg; 0.45% Ni; 0.20% Cr. This cast iron was made in an induction furnace. Nodular changes were obtained with the "In mold" method, with the help of prealloy FeSiMg with 10-16% Mg, added into the reaction chamber in a proportion of 1.1% of the treated cast iron.

## Heat treatments

The parameters of the heat treatment done were the following: for the lots A, B, C , submitted to isothermal hardening, the austenizing temperature  $T_A = 900$  [°C]. and for the

lots: A<sub>1</sub>, B<sub>1</sub>, and C<sub>1</sub>. submitted to Dual-Phase bainitic treatment, the austenizing temperature  $T_A = 830$  [°C], the maintained time at austenizing temperature,  $\tau_A = 60$  [min] for all the lots.

The temperature at isothermal level, for all the lots was:  $T_{iz} = 300, 350$  and  $400$  [°C]; the maintained time at the isothermal level,  $t_{iz} = 10; 20; 30; 40; 50$  and  $60$  [min]. All these 6 experimental lots were performed at isothermal maintenance in salt-bath, being the cooling after the isothermal maintenance was done in air.

### Experimental results

From this material, 48 typical of Hardness (HB), tensile strength ( $R_m$ ), elongation (A) and impact strength (KCU) test specimens was done and after the heat treating, it was determined these properties. The values of the mechanical results are presented in table 1 and figures 1 - 4.

**Table 1:** The experimental values of mechanical properties, for various  $T_{iz}$  and  $\tau_{iz}$

Lot	$T_A$ [°C]	$\tau_A$ [min]	$T_{iz}$ [°C]	$\tau_{iz}$ [min]	HB	$R_m$ [N/mm <sup>2</sup> ]	KCU [J/cm <sup>2</sup> ]	A [%]
A	900		300	10	451	1435	40	1,1
				20	426	1420	45	1,5
				30	415	1350	53	2,5
				40	408	1300	63	3,2
				50	390	1280	69	3,5
				60	383	1130	85	4,5
B		60	350	10	420	1250	55	2,8
				20	408	1140	65	4,0
				30	390	1070	70	4,2
				40	331	980	90	5,4
				50	315	920	100	6,5
				60	311	910	120	7,6
C			400	10	375	950	85	5,5
				20	321	930	90	6,8
				30	306	890	98	7,9
				40	302	860	115	8,0
				50	298	850	134	8,1
				60	292	815	135	8,8
A <sub>1</sub>	830		300	10	408	1290	58	3,5
				20	395	1270	65	3,7
				30	370	1200	74	4,9
				40	355	1160	88	5,5
				50	333	1100	95	6,4
				60	323	1010	106	7,2
B <sub>1</sub>		60	350	10	381	1070	65	4,8
				20	355	1060	78	5,4
				30	344	1000	85	5,6
				40	337	920	93	5,9
				50	311	880	105	7,2
				60	303	780	137	8,8
C <sub>1</sub>			400	10	311	920	70	7,1
				20	306	900	93	7,6
				30	302	870	107	8,4
				40	298	850	118	9,5
				50	285	800	137	10,2
				60	268	720	145	11,5



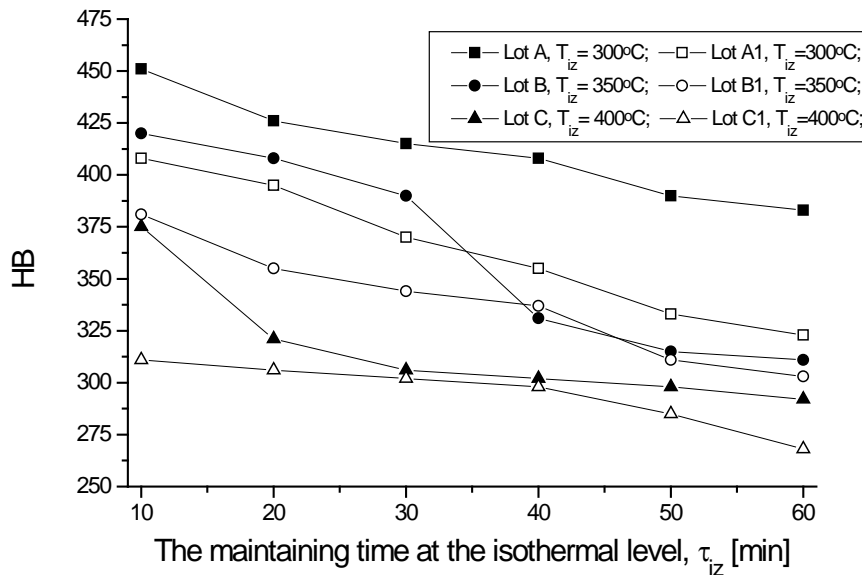

**Figure 1:** The influence of the heat treatment over the hardness (HB) properties, for different maintaining time

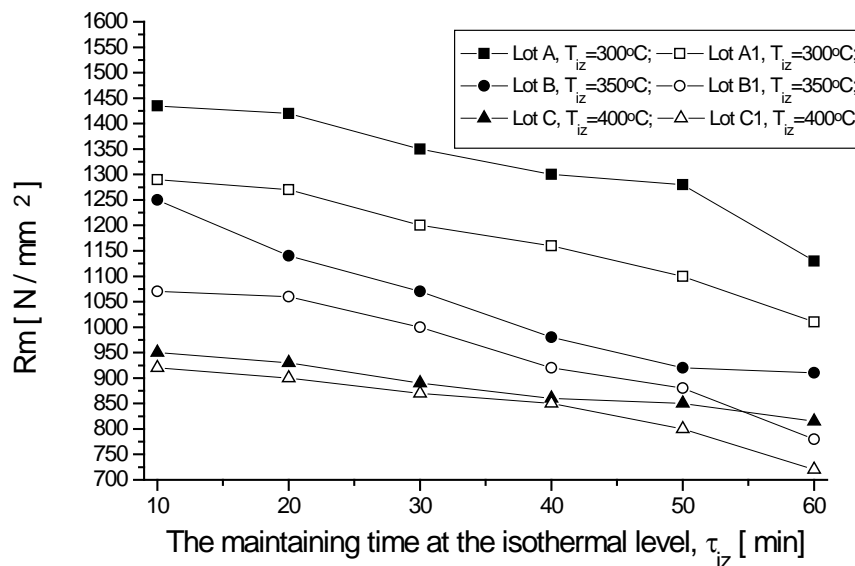

**Figure 2:** The influence of the heat treatment over the tensile strength ( $R_m$ ) properties, for different maintaining time

It can be certainly observed a normal evolution of the values for mechanical characteristics :

-when maintaining time at the isothermal level for both heat treatments is growing then  $R_m$  and HB are decreasing and A with KCU are increasing.

-when maintaining time at the same temperature of the isothermal level for both heat treatments is increasing than  $R_m$  and HB are decreasing , A and KCU are increasing.

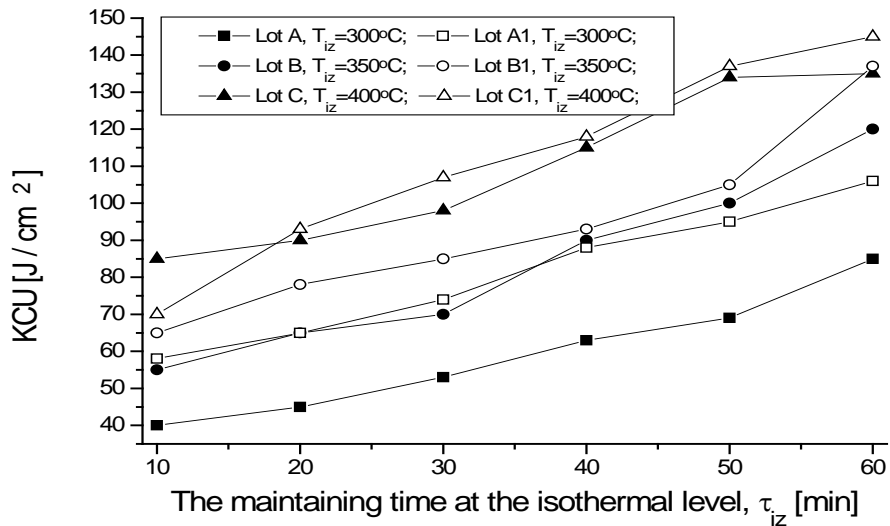

Figure 3: The influence of the heat treatment over the impact strenght (KCU) properties, for different maintaining time

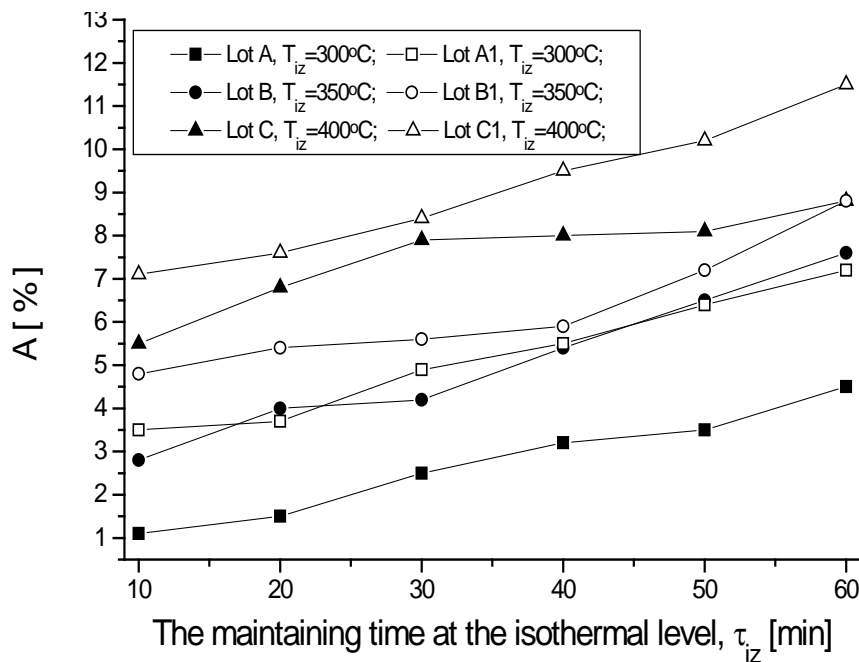

Figure 4: The influence of the heat treatment over the elongation (A) properties, for different maintaining time

-comparing the values of the mechanical properties for both heat treatments in the case of the classical isothermal austempering heat treatment, at the same time and temperature, the isothermal level determining high values for Rm and HB and low for KCU and A comparing with the “Dual-Phase” bainitic heat treatment.

This evolution of the mechanical properties is determined by the structural changes reported to the parameters of the heat treating. This evolution of the mechanical properties is determining by the structural constituents for each heat treatment (Chou et. al., 1992).

In the case of lots A and A<sub>1</sub> structure can be constituted of inferior bainite, residual austenite and martensite. These constituents are determining high values for Rm and HB, and less high for A and KCU (Guilermany et. al., 1990).

Comparing the both lots suppose a high value of inferior bainite and martensite in lot A comparing to lot A<sub>1</sub> (see the values of the mechanical properties Rm and HB). Together with increasing the level of the isothermal maintenance temperature inside the structure will appear the superior bainite and the martensite will disappear (lot C and C<sub>1</sub>). The lot Cs characterize by the high values of A and KCU. This is because of the ferrite value obtained in the heat

treatment. This constituent is characteristic for the “Dual-Phase” heat treatment and appears when we need superior values for and KCU, in the case of the for the samples that were maintained at 60 min.

In the same time there can be observed a general characteristic about the studied lots: less maintaining time for the isothermal variation provides higher values of HB and Rm but lower of A and KCU.

This can be explained by the time of the isothermal level maintenance, followed by air cooling at the room temperature, is increasing the proportion of martensite, a constituent which is determining higher values for Rm and HB and lower for A and KCU in the structure of the lots.

### **Conclusion:**

The isothermal bainitic transformation in a Ni-Cu S.G. cast iron was studied in the temperature range of 300-400° C and with maintaining time between 10-60 minutes. The main results are summarized as follows:

(a) Utilizing the Dual-Phase bainitic heat treatment (lots C<sub>1</sub> ) combines a lot of superior attributes used in the automotive industry. The values of Rm = 720-930 [N/mm<sup>2</sup>]; A = 7.1-11.5 [%] and KCU = 70-145 [J/cm<sup>2</sup>], assure a good comportment to fatigue strength.

(b) Very important are the variations of the heat treatments' parameters for both treatments over the values of the mechanical properties.

(c) It is possible to obtain a acicular structure with high values for mechanical properties. That is a good reason for the replacement of the iron used by the moment in the automotive industry.

### **References:**

Batra, U., Ray, S. and Prabhakar, SR. Effect of austenitization on austempering of copper alloyed ductile iron, *Journal of Material Engineering and Performance*, v. 12, n. 5, pp. 597-601, 2003.

Chou, J.-M., Hon, M.-H. and Lee, J.-L. The austenite transformation in ferritic ductile cast iron. - *Materials Science and Engineering, A*. 158, pp. 241-249. 1992.

Erić, O., Rajnović, D., Zec, S., Sidjanin, L. and Jovanović, M. Microstructure and fracture of alloyed austempered ductile iron, *Materials Characterization*, 57, pp. 211-217, 2006.

Guilemany, J.M., Llorca-Isern, N. Mechanism of Bainitic Transformation in Compacted Graphite Cast Iron, *Metallurgical Transactions A*, 21A, pp. 895-899, 1990.

Simon, D. ADI- a new material for the automotive engineer, *Foundry Trade J.*, 2, pp. 66-67, 1996.

# TRIBOLOGICAL PROPERTIES OF THERMAL SPRAY COATINGS

*Prof. Ph.D. Virgil Geaman*  
*Lecturer Ph.D. Mihai Alin Pop*  
*Assoc. Prof. Ph.D. Dana Luca Motoc*  
*Prof. Ph.D Irinel Radomir*  
Transilvania University of Brasov, Romania

---

## Abstract

Thermal spraying techniques are coating processes in which melted or heated materials are sprayed onto a surface. Thermal spray coatings have a wide range of applications, for instance, by repairing machine parts damaged in service or by the production of parts with high wear resistance. Coating quality is usually assessed by measuring its porosity, oxide content, macro and microhardness, bond strength and surface roughness. Generally, the coating quality increases with increasing particle velocities. The present paper analyses the thermal spray coatings by their tribological properties.

---

**Keywords:** Coatings, plasma spray, wear, adhesion, pin-on-disc

## Introduction:

Thermal spraying is the process of applying coatings of high performance materials, such as metals, alloys, ceramics, cermets, and carbides, onto more easily worked and cheaper base materials [1].

Plasma spraying is part of thermal spraying, a group of processes in which finely divided metallic and non-metallic materials are deposited in a molten or semi-molten state on a prepared substrate. Plasma spraying is also the most common method for preparing ceramic coatings which are widely used for structural applications in order to improve wear resistance, corrosion, oxidization and erosion [2,3,4,5].

Plasma sprayed  $\text{Al}_2\text{O}_3/\text{TiO}_2$ , for example, have been widely used as wear-resistant coatings in textile, machinery, and printing industries [6]. Aluminum oxide ( $\text{Al}_2\text{O}_3$ ) is a well-established and relatively inexpensive material, which is used in many tribological applications in the form of sintered monolithic components (as wear inserts) or as coatings [7].

$\text{Al}_2\text{O}_3$  ceramic coatings, having superior hardness, chemical stability and refractory character, are commonly utilized to resist wear by friction and solid particle erosion [8,5]. Applications of these materials vary widely but encompass cutting tools, grinding wheels, and certain critical automotive components like piston rings [7].

Ceramic coatings based on alumina are a good alternative in applications where good tribological properties, elevated hardness and high thermal resistance are required. Alumina is brittle and the addition of titanium oxide leads to a balanced equilibrium of properties maintaining enough hardness and increasing considerably the coating toughness.

Titanium oxide has a lower melting point and plays a role of binding alumina grains to achieve coatings with a higher density [9].

During the past 10 years, many research groups have prepared successfully nanostructured ceramic coatings using plasma spraying and other thermal spraying methods. Recently, the studies on nanostructured materials have shown that they could present

excellent properties that differ markedly from their conventional bulk materials [10].

## 2. Materials

Many researchers reported that the  $\text{Al}_2\text{O}_3\text{-TiO}_2$  coatings containing 13 wt.% of  $\text{TiO}_2$  showed the most excellent wear resistance among the  $\text{Al}_2\text{O}_3\text{-TiO}_2$  ones. They interpreted the excellent wear resistance of the nanostructured  $\text{Al}_2\text{O}_3\text{-13 wt.%TiO}_2$  coating than that of conventional  $\text{Al}_2\text{O}_3\text{-13 wt.%TiO}_2$  coating as the presence of partially melted regions inside the nanostructured coatings [3].

Tribological behaviour of  $\text{Al}_2\text{O}_3\text{-13%TiO}_2$  nanostructured and conventional coatings deposited by atmospheric plasma spray has been experimentally analysed by A. Rico et al. [9].

Conventional coatings were obtained from commercial powder METCO130 and modified. Nanostructured  $\text{Al}_2\text{O}_3\text{-13%TiO}_2$  coatings were prepared from agglomerates. The agglomerates, constituted by nanometric particles with average size of 200 nm, were prepared by spray drying. In both cases, conventional and nanostructured coatings, a bond coat type: Ni-Al-Mo 90/5/5 (%wt) was inserted between substrate and ceramic coating to enhance the adherence.

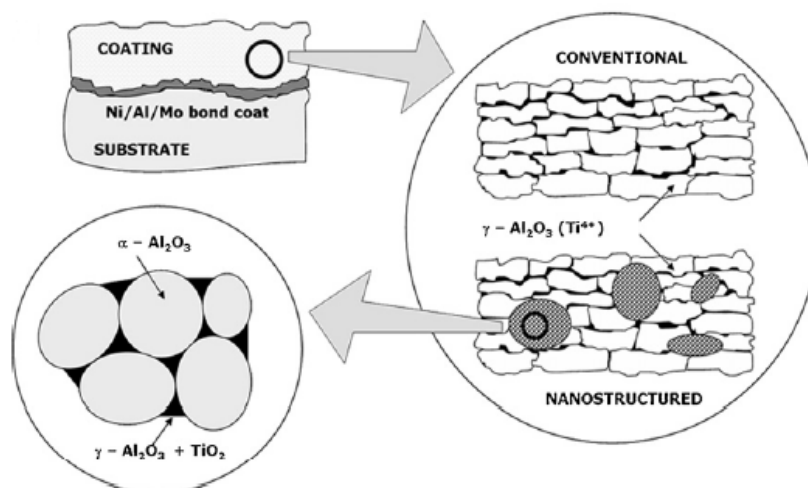

Fig. 1. Diagram showing the hierarchical microstructure of the nanostructured coating. A comparison with the conventional coating is also included [9].

## 3. Wear resistance

### 3.1. Dry sliding wear resistance of alumina-titanium coatings

Wear tests were carried out in a wear testing machine with a pin-on-disc configuration under dry sliding conditions without eliminating the debris formed. Both materials exhibit a transition between mild and severe wear regimes, given by an abrupt increment of the wear rate. The transition pressure is higher for the nanocoating, extending therefore, the mild wear regime. Both conventional and nanostructured coatings exhibit a typical splat microstructure, very commonly observed in thermal spray coatings.

In Fig. 1, a diagram showing the hierarchical microstructure of the nanostructured coating, and a comparison to the conventional one, is presented. The first microstructural level corresponds to the splat morphology. In this level, the cracks interact with the splat borders. The second microstructural level is related to the presence of the partially melted zones. In this level, the cracks can interact not only with the splat boundaries, but with the nanoparticles placed inside the partially melted zone. The second microstructural level is not present in the conventional coating.

The wear mechanisms identified in both coatings are predominantly related to brittle propagation of cracks, so the material fracture toughness could be considered the key parameter controlling the wear behaviour.

When the severity of the contact is low, for nominal pressures below the critical one (20MPa and 30MPa for the conventional and nanostructured coatings, respectively), the main wear mechanism is in both coatings the crack propagation through the splats boundaries, because these are the weakest regions. At high loads, for nominal pressures above the critical one (20MPa and 30MPa for the conventional and nanostructured coatings, respectively) transversal cracks growing from the top surface can be detected. These cracks tend to pass through the splats, easily reaching the boundary between the ceramic coating and the bond layer and multiplying the damage in the material by complete spalling. They are associated with a substantial increment in the friction coefficient and a huge rise of several orders of magnitude in wear rates [9].

### 3.2. Fretting wear resistance of alumina-titanium coatings

W. Tian et al. investigated the fretting wear behaviour of alumina-titanium fabricated also by plasma spray [11]. In this case a bond coating of NiCrAl was deposited on the metal substrate. Fretting is a small amplitude oscillatory movement occurring between contacting surfaces, which are usually nominally at rest. That movement may result from external vibration (fretting wear) or cyclic stress (fretting fatigue), and both cases may give rise to service failure due to the production of debris or the initiation and propagation of fatigue cracks.

Fretting wear tests of nanostructured and conventional  $\text{Al}_2\text{O}_3$ -13wt%  $\text{TiO}_2$  coatings, were carried out on a PLINT fretting fatigue machine (Fig.2.) under unlubrication condition.

The wear scar of conventional coating was much deeper and wider than that of nanostructured coating under both C1 and C2 fretting wear conditions (Table 1). In addition, increasing the displacement amplitude, the depth of wear scar was not obviously

Table 1. Depth of wear scar (nm), [11]

	C1 fretting condition (D=60 $\mu\text{m}$ ; P=50N; N=10.000)		C2 fretting condition (D=200 $\mu\text{m}$ ; P=50N; N=10.000)	
Nanostructured coating	6	7		
Conventional coating	12	>20		

increased for nanostructured  $\text{Al}_2\text{O}_3$ -13 wt%  $\text{TiO}_2$  coatings. For the conventional coating, the depth and width of wear scars obviously increased when fretting displacement amplitude increased. It could be concluded that the nanostructured  $\text{Al}_2\text{O}_3$ -13 wt%  $\text{TiO}_2$  coatings possess much better fretting wear resistance than the conventional  $\text{Al}_2\text{O}_3$ -13 wt%  $\text{TiO}_2$  coatings [11].

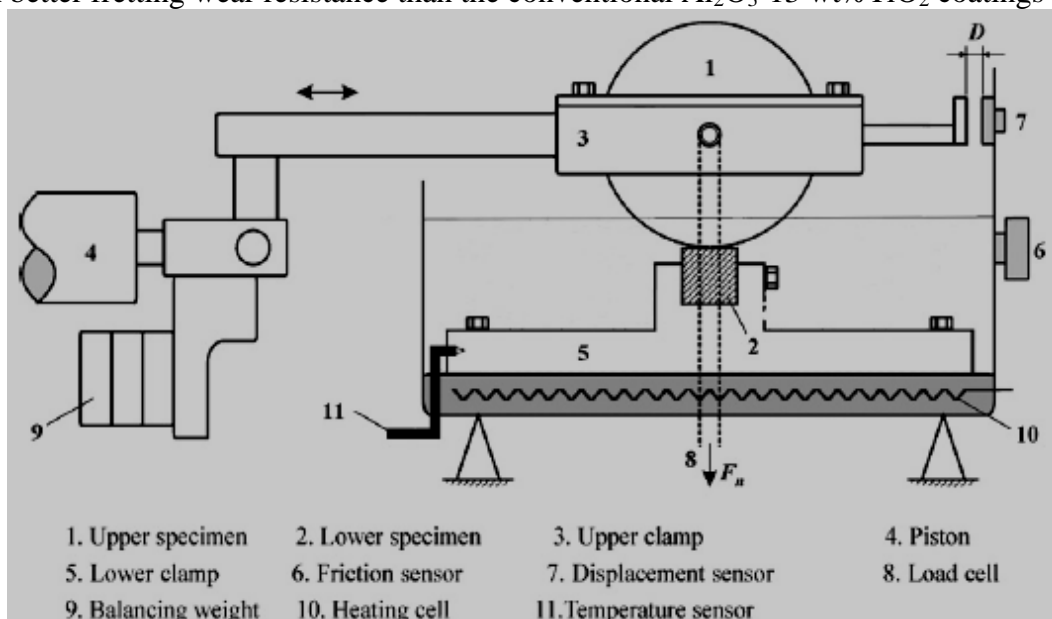

Fig. 2. Schematic illustration of fretting wear testing machine [11]

#### 4. Effects of plasma spraying conditions on wear resistance

Previous studies have shown that the coating microstructure and properties are not only dependent of the characteristics of the feed powder, but also of the thermal spray condition [6]. Spraying conditions such as critical plasma spray parameter (CPSP) and distance between a spraying gun and a substrate can affect the final coating microstructure and consequently the wear resistance [3, 4].

##### 4.1. Effects of CPSP on wear resistance

In the nanostructured  $\text{Al}_2\text{O}_3\text{-TiO}_2$  coatings, the amount of partially melted regions varies with the CPSP [3]. The partially melted regions can play an important role in determining the overall hardness of the coatings because they are softer than the fully melted regions and their volume fraction is varied in the coatings. Thus, the overall hardness of the coatings increases as the volume fraction of partially melted regions decreases with increasing CPSP [4].

The hardness increase generally matched with the increase in wear resistance, although the hardness and wear resistance were not correlated in the coating fabricated with the low CPSP [3]. Anyway, the addition of 25 vol.% of partially melted regions as toughening reinforcements in the coating fabricated with the low CPSP provided the better wear resistance than that of the coatings fabricated with higher CPSP because the improved resistance to fracture might compensate a deleterious effect of the hardness decrease [3].

##### 4.2. Effects of spray distance on wear resistance

If the spray distance is too short, nanopowders may be insufficiently melted, or the moving speed of nanopowders is not fast enough to form dense coating layers. Thus, the plasma spraying technique should be conducted at an appropriate distance or farther in order to enhance the deposition efficiency of nanopowders.

The temperature and speed of plasma flame or spray nanopowders are schematically plotted as a function of spray distance as shown in Fig. 3.

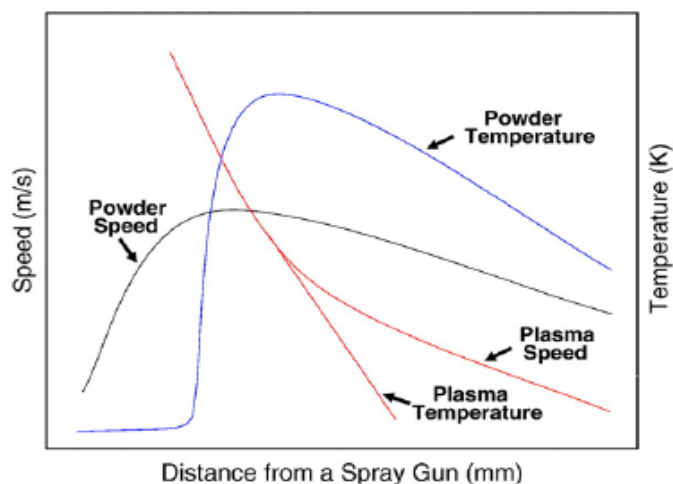

Fig. 3. Temperature and speed of plasma flame, as a function of spray distance from spray gun [3].

According to Eun Pil Song et co. the coatings fabricated at the long spray distance contained a considerable amount of pores and partially melted regions resulting the deterioration of the wear resistance [3]. When the spray distance decreases, dense coatings could be fabricated. In these coatings, cracks or spelled-outs of oxides were hardly found on the smoothly worn surface.

##### 4.3. Coefficient of friction

Results of coefficient of friction measurement by pin-on-disc technique, are summarized in the figure 4. For all coatings, the coefficient of friction reaches the highest values for the

lowest pin load. With increasing load, the coefficient of friction tends to a steady-state value [12].

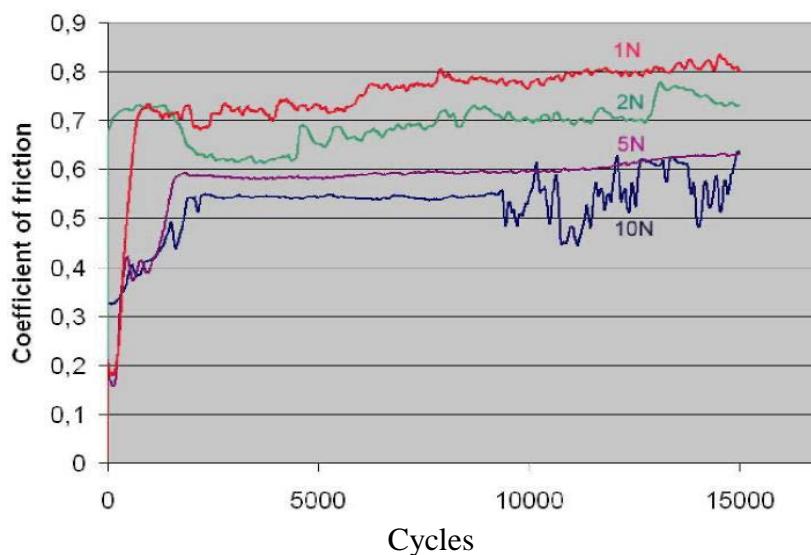
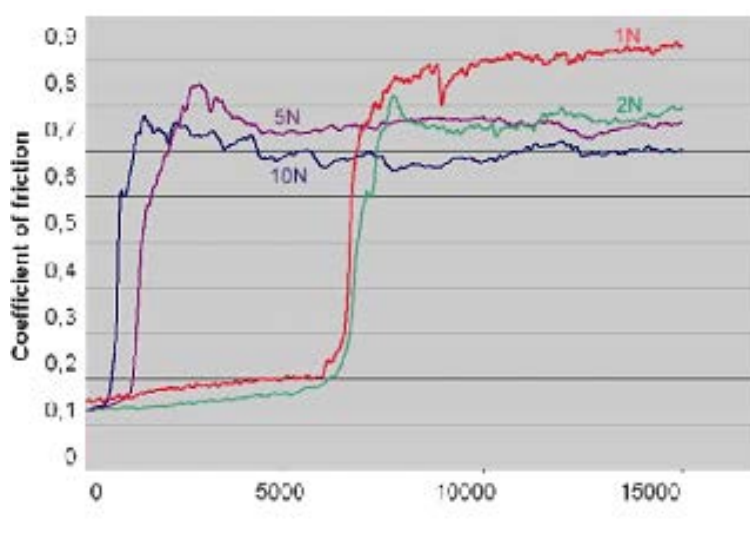

Fig. 4. Coefficient of friction records for  $\text{Cr}_3\text{C}_2\text{-NiCr}$  coating

In the Fig. 5, the coefficient of friction records for  $\text{Cr}_3\text{C}_2\text{-NiCr}$  can be seen.

In the case of electric arc sprayed coatings 95 MXC, the coefficient of friction records for 1N and 2N had very long rise time (Fig. 5).



Cycles

Fig. 5. Coefficient of friction records for 95 MXC coating

The 95 MXC coating has, due to its heterogenous structure, worse friction and wear properties. For tribological application it could be recommended only if it could not be used for plasma sprayed coatings.

## 5. Conclusions

In this paper tribological behaviour of alumina-titanium nanostructured and conventional coatings has been analysed, leading to the following conclusions:

- In the low load regime (below the critical pressure) nanostructured coating wear rates are lower than those for the conventional coating in the same regime.
- The wear scar of conventional coating was much deeper and wider than that of nanostructured coating under both C1 and C2 fretting wear conditions. It could be



concluded that the nanostructured  $\text{Al}_2\text{O}_3$ -13 wt% $\text{TiO}_2$  coatings possess much better fretting wear resistance than the same conventional coatings.

- The addition of 25 vol.% of partially melted regions as toughening reinforcements in the coating fabricated with the low CPSP provided the better wear resistance than that of the coating fabricated with the higher CPSP because the improved resistance to fracture might compensate a deleterious effect of the hardness decrease.
- When the spray distance decreases, the dense of coatings could be fabricated. In these coatings, cracks or spalled-out of oxides were hardly found on the smoothly worn surface.

### References:

- Witherspoon, F.D., Massey, D.W., Kincaid, R.W., Whichard, G.C. & Mozhi, T.A. (2002). *High Velocity Pulsed Plasma Thermal Spray*. Journal of Thermal Spray Technology, Vol. 11(1), 2002, pp. 119-128.
- Fauchais P, - *Topical review - Understanding plasma spraying*, Journal of physics and applied physics, vol. 37, 2004, pp. 86-108.
- Eun P.S., Jeehoon A., Sunghak L., Nack J. K. - *Effects of critical plasma spray parameter and spray distance on wear resistance of  $\text{Al}_2\text{O}_3$ -8 wt.% $\text{TiO}_2$  coatings plasma-sprayed with nanopowders*, Surface & Coatings Technology 202 (2008) pp. 3625–3632.
- Eun P.S., Jeehoon A., Sunghak L., Nack J.K. - *Microstructure and wear resistance of nanostructured  $\text{Al}_2\text{O}_3$ -8wt.% $\text{TiO}_2$  coatings plasma-sprayed with nanopowders*, Surface & Coatings Technology 201 (2006) pp. 1309–1315.
- Jingde Z., Kangning S., Jiangting W., Baoyan T., Hongsheng W., Yansheng Y. - *Sliding wear behavior of plasma sprayed  $\text{Fe}_3\text{Al-Al}_2\text{O}_3$  graded coatings*, Thin Solid Films 516 (2008) pp. 5681–5685.
- Meidong W., Leon L.S. - *Effects of the powder manufacturing method on microstructure and wear performance of plasma sprayed alumina–titania coatings*, Surface & Coatings Technology 202 (2007) pp. 34–44.
- Dearnley P.A., Kern E. and K L Dahm K.L.- *Wear response of crystalline nanocomposite and glassy  $\text{Al}_2\text{O}_3$ -SiC coatings subjected to simulated piston ring/cylinder wall tests*, Proc. IMechE Vol. 219 Part L: J. Materials: Design and Applications (2005) pp. 121-137.
- Zhijian Y., Shunyan T., Xiaming Z., Chuanxian D. - *Microstructure and mechanical properties of  $\text{Al}_2\text{O}_3$ -Al composite coatings deposited by plasma spraying*, Applied Surface Science 254 (2008) pp. 1636–1643.
- Rico A., Rodriguez J., Otero E., Zeng P., Rainforth W.M. - *Wear behaviour of nanostructured alumina–titania coatings deposited by atmospheric plasma spray*, Wear 267 (2009) pp.1191–1197.
- Huang C., Soowohn L., Xuebing Z., Chuanxian D. - *Evaluation of unlubricated wear properties of plasma-sprayed nanostructured and conventional zirconia coatings by SRV tester*, Wear 260 (2006) pp. 1053–1060.
- Tian W., Wang Y., Yang Y. - *Fretting wear behavior of conventional and nanostructured  $\text{Al}_2\text{O}_3$ -13 wt% $\text{TiO}_2$  coatings fabricated by plasma spray*, Wear 265

# ENERGY COST AND OPTIMIZATION OF A CLOSED CIRCUIT CRUSHING PLANT WITH A CENTRIFUGAL CRUSHER

*Elias Stamboliadis*

Professor, Technical University of Crete

*Dimitris Stamboliadis*

Mechanical Engineer, STEI of Piraeus

---

## Abstract

A closed circuit crushing consists of a crusher that breaks the feed material, a screen that classifies the material and a conveyor system that returns the over size back to the crusher.

The capacity of a centrifugal crusher with a given motor power depends on its rotation frequency. The lower the rotation frequency the lower the specific energy, or breakage intensity, that the particles obtain before breakage and hence the greater the capacity of the crusher to provide a low specific energy to the feed particles

On the other hand, according to the breakage model the fraction of the feed that breaks below the feed size class is greater as the kinetic energy given to the particles increases. The combination of these two parameters has two effects:

- a) the energy cost per mass of the material broken by the crusher decreases as the breakage intensity decreases and
- b) the circulating load that has to be returned to the crusher increases as the breakage intensity decreases.

This paper shows how to calculate the optimum crusher breakage intensity, or rotation frequency, in order to minimize the energy cost per ton of the product broken below size.

---

**Keywords:** Centrifugal crusher, energy cost, crushing circuit optimization

## Introduction

In crushing circuits the feed material to the crusher is not broken below the desired size in one pass and for this reason the product is usually screened. The coarse fraction returns to the crusher through a system of conveyor belts. The energy consumed by the crusher in each pass depends on the feed rate ton/h and the specific energy kWh/ton that is provided to the material during breakage, (breakage intensity). In general the higher the breakage intensity the finer the product obtained.

The method to control the breakage energy per ton of the material depends on the type of the crusher. In jaw crushers for instance, the breakage energy is controlled by the discharge opening and it is higher as the opening is smaller. This can be explained as follows. The motor power is given, the residence time in the crusher increases as the discharge opening is reduced and the feed rate drops accordingly, so the energy per unit mass of the material (breakage energy) increases. On the other hand the breakage energy can be reduced by increasing the discharge opening.

In centrifugal crushers, which are examined in the present work, the provided breakage energy depends on the rotation frequency of the crusher disk. The higher the rotation frequency the higher the breakage intensity provided to each particle. In opposition to the jaw crushers there is no restriction to the feed rate due to the discharge opening and the

parameters that control the feed rate are the motor power and the velocity of the particles in the crusher that determines the residence time. For a given motor power the higher rotation frequency gives higher breakage intensity and consequently the capacity drops. At low frequencies and low breakage energies the crusher capacity increases and the limit is imposed by the residence time that decreases with decreasing rotation frequency.

Different materials have different strengths and require smaller or higher breakage intensity. For the same material the higher the breakage intensity provided by the crusher the finer the size of the product obtained. In crushing circuits all the material is required to break below a given size and this is achieved by classification of the product on a screen. The passing fraction is the final product while the coarse fraction is recycled to the crusher that receives the fresh feed as well. The higher the quantity of the recycled material, the higher the quantity to which the crusher has to provide the breakage intensity. It can be understood now that the higher the breakage intensity the lower the feed rate but since the product is finer the recirculation of the coarse size will be reduced.

From the point of special arrangement, when the material passes through the crusher and then through the screen it loses height and the recirculation of the coarse fraction requires energy to return back to the crusher. Even if the conveying system does not consume energy for its operation one has to provide energy in order to elevate the circulating material back to the crusher.

Following the analysis above, it is obvious that for the optimization of the capacity of the crushing circuit one has to take into consideration the breakage rate of the material as a function of the breakage intensity, the power of the crusher motor and the height lost in the circuit. In a real plant one should also take into consideration the energy consumed for the operation of the crusher, the screen and the conveyors even if the circuit operates empty. Initially the present work assumes a system without energy consumption for the equipment when running empty in order to show the physical dimension of the problem and it will be easy for the reader to transfer the solution to an existing plant.

### **The centrifugal crusher**

A centrifugal crusher consists mainly of a rotating disc with diameter  $D=2R$ . The feed material drops at the center of the disc and is forced to rotate by two radial bars (wings) with height  $h$  starting from a distance  $R_o$  from the center of the disc up to its periphery, a length  $R$  from the center. A photo of the experimental crusher used appears in Figure 1.

Due to the rotation the feed particles are forced to the periphery by the centrifugal forces acting on them. At the edge of the periphery the particles escape from the disc having a velocity  $V$  made of two components, a peripheral velocity  $V_p$  due to the rotation and a radial centrifugal one  $V_c$  vertical to the periphery. The peripheral velocity  $V_p$  is calculated by equation (1), where  $N$  is the rotation frequency.

$$V_p = \pi \cdot D \cdot N \quad \dots(1)$$

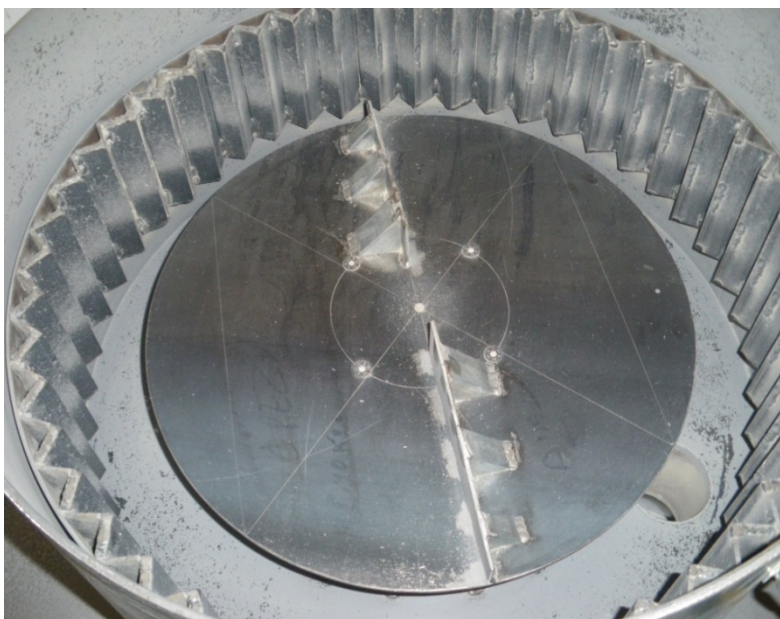

Figure 1: Inside view of the centrifugal crusher

The radial velocity  $V_c$  is perpendicular to the peripheral velocity  $V_p$  but it has the same magnitude given by eq. (1), as is proven by D. Stamboliadis [1] and described by E. Stamboliadis et. al. [2]

The resultant  $V$  is given by equation (2) and its direction is at  $45^\circ$  to the radius because its components are equal..

$$V^2 = V_c^2 + V_p^2 \quad \dots(2)$$

The kinetic energy  $E$  of each particle is given by equation (3), where  $m$  is the mass

$$E = \frac{1}{2} \cdot m \cdot V^2 \quad \dots(3)$$

The specific energy of the particle  $e=E/m$ , energy per unit mass, also called breakage intensity, is given by equation (4), taking in to consideration eq. (1) and (2). It depends only on the diameter of the disc and the rotation frequency and it is the same for any particle regardless of mass.

$$e = \frac{E}{m} = (\pi \cdot D \cdot N)^2 \quad \dots(4)$$

The particles leaving the disc crush on the opposite wall and break into smaller ones due to the kinetic energy they acquired on the disc. The lining of the opposite wall is designed to have blades at  $45^\circ$  so that the particles strike vertical on them.

The total energy obtained by all the particles is provided by the motor that has a power  $P$ . If the feed rate of the material to the crusher is  $Q$  there is a relationship between the motor power, the through put rate of the material and the specific energy that the particles acquire before breakage and is given by equation (5).

$$P = Q \cdot e \quad \dots(5)$$

Solving equation (5) for the capacity  $Q$  taking into consideration (4) one obtains equation (6), which shows that, the throughput capacity is inversely proportional to the breakage intensity given to the particles.

$$Q = \frac{P}{e} = \frac{P}{(\pi \cdot D \cdot N)^2} \quad \dots(6)$$

Equation (6) also indicates that the throughput capacity is inversely proportional to the square of the rotation frequency that can be varied on will, while the disc diameter and the motor power are given and cannot vary for a given installation.

The residence time of a particle in the crusher is the time interval required by a particle to run the distance from  $R_o$  to  $R$ , the beginning and the end of the wings. This time interval  $t$  depends on the rotation frequency  $N$  and is given by equation (7), Manoussaki [3].

$$t = \frac{1}{2 \cdot \pi \cdot N} \cdot \ln\left(\frac{R}{R_o}\right) \quad \dots(7)$$

The maximum volume  $V_{max}$  that the material can occupy on the disc depends on the height  $h$  of the wings. The maximum quantity of material  $M_{max}$  that can be hold on the disc depends on the bulk density  $\rho$  of the material and is given by equation (8)

$$M_{max} = V_{max} \cdot \rho = \frac{\pi}{4} \cdot D^2 \cdot h \cdot \rho \quad \dots(8)$$

The percent ratio  $f$  of the mass  $M$  of the material in the crusher to  $M_{max}$  will be referred to as the saturation degree  $f = 100 \cdot M/M_{max}$ . It is obvious that the feed rate of the crusher cannot be greater than the one that gives  $f \geq 100\%$ , otherwise it will block.

### The breakage model

The specific energy, required to break a particle in the centrifugal crusher depends on its size. The particles of a particulate material are usually classified by screening in size classes and each class has an upper size  $x_1$  and a smaller size  $x_2$ . The average size  $d$  of the class is defined as  $d = \sqrt{x_1 \cdot x_2}$ , As the ratio  $\chi_1/\chi_2$  approaches to 1 the particles become isodimensional and their size tends to  $d$ .

When a size class breaks, the fraction  $F_d$  of its total mass that breaks below its lower size, depends on the breakage intensity and is given by equation (9), Stamboliadis [4]

$$F_d = \frac{e}{\Delta H_d + e} \quad \dots(9)$$

The quantity  $\Delta H_d$  is defined as the specific enthalpy required breaking a particle of size  $d$ . When the breakage intensity  $e$  provided by the crusher becomes  $e = \Delta H_d$  then  $F_d = 0,5$ . By measuring the breakage intensity that gives  $F_d = 0,5$  for several feed size classes one can find the energy size relationship. As an example the corresponding relationships for limestone and serpentine are given by equations (10) and (11) respectively, for  $d$  in mm [4].

$$\text{Limestone} \quad \Delta H_d = 1250 \cdot d^{-0.57} \quad \text{J/kg} \quad \dots(10)$$

$$\text{Serpentine} \quad \Delta H_d = 6190 \cdot d^{-1.47} \quad \text{J/kg} \quad \dots(11)$$

After this it is practically possible to calculate from equation (9) the mass fraction  $F_d$  of any size class of a material that breaks below the size class indicated by the average  $d$  for any breakage intensity  $e$ . Equation (9) is homographic and the fraction produced tends to unit as the breakage intensity increases, while equations (10) and (11) show that bigger particles break easier than smaller ones.

### The crushing circuit

Figure 2 represents a typical crushing circuit. The fresh feed is introduced into the crusher where it breaks at a fraction determined by the rotation frequency and the product goes to the screen with aperture the lower size of the fresh feed. The fraction finer than the screen aperture passes through it, while the coarser fraction is returned to the crusher, via the conveyors.

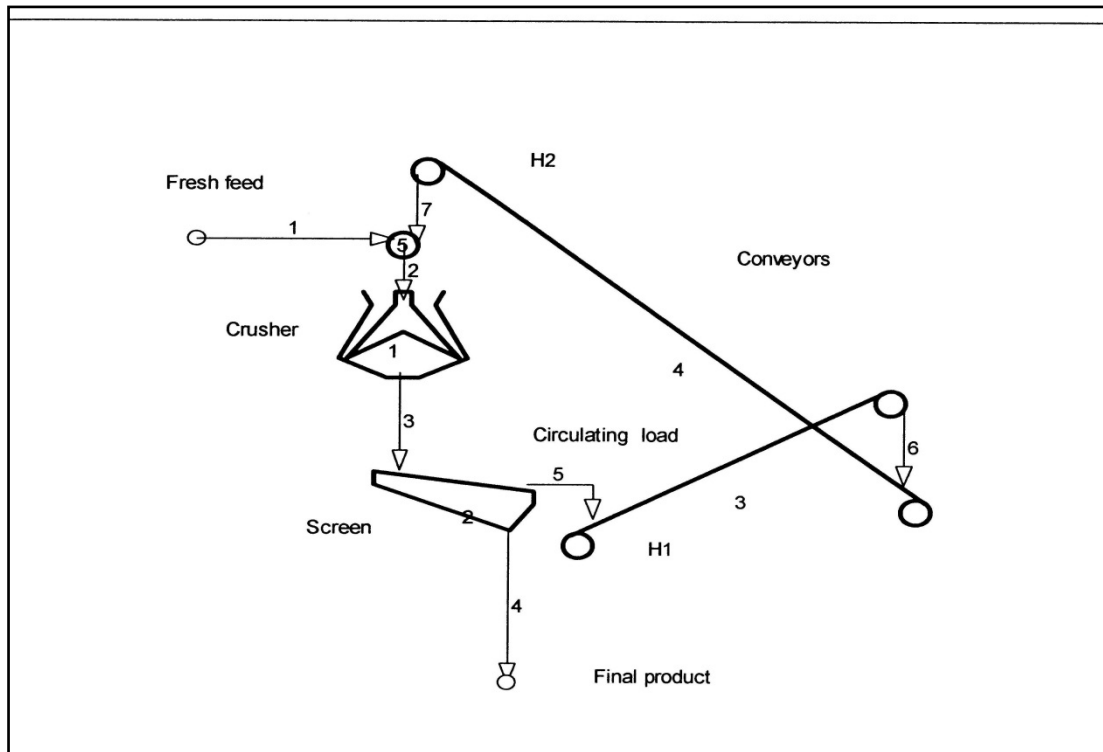

Figure 2: Crushing circuit

It is easy to see that after crushing and screening the material ends to a lower level losing height. It will take energy to lift the coarse recycled fraction from level  $H_1$  to level  $H_2$  at the feed point of the crusher. It is helpful to notice the following that hold at equilibrium.

The quantity of the final fine product equals that of the fresh feed.

The total feed to the crusher is made of the fresh feed and the recirculating coarse fraction.

According to equations (6) and (9) the total feed to the crusher increases as the rotation frequency decreases because the coarse fraction increases.

Opposite, according to the same equations, the fraction of the crusher product below the screen size is greater as the rotation frequency increases.

The energy required to lift the recirculated coarse product is higher as the breakage energy is reduced.

### A case study

It is clear from the above analysis that the effect of breakage energy has an opposite effect on the throughput capacity and on the feed fraction that breaks below size. One should be looking for an optimum rotation frequency, or the same, optimum breakage intensity, for which the production of fine material is maximum for the same total energy input. Even more find the conditions under which the energy efficiency is greater, that is the energy consumed by the crusher per ton of the final product is greater compared to the total energy consumed by the crushing circuit as a whole.

Initially let us assume that the crusher, the screen and the conveyor belts are ideal machines and consume no energy for friction when they run idle. Let us also assume the technical parameters as follows: The feed material is limestone, of size 4-5,6 mm that gives an average size  $d=4.73$  mm, a bulk density  $1400 \text{ kg/m}^3$ , and specific enthalpy  $\Delta H_d= 500 \text{ J/kg}$ , or (0.139 kWh/ton). The screen aperture is 4 mm, and the height loss is  $H_{loss} = (H_2 - H_1) = 6 \text{ m}$ . The disc diameter of the crusher is  $D=0,5 \text{ m}$ , the radius  $R=0.265 \text{ m}$ , the height of the wings  $h=0,05 \text{ m}$ , the distance of the wings from the center  $R_o=0.025 \text{ m}$  and the motor power  $P=3 \text{ kW}$ .

The throughput of the crusher

According to equation (6) the throughput of the crusher is presented in Figure 3 and tends to infinity as the rotation frequency tends to zero.

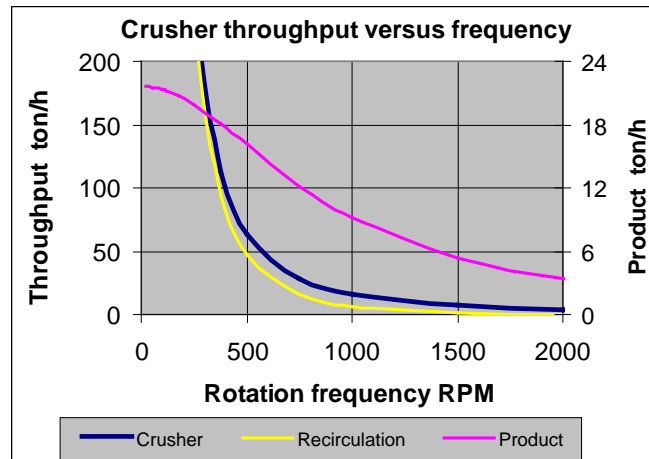

Figure 3: Throughput versus rotation frequency

The corresponding production rate  $B_d$  (right axis) of the fine material -4 mm is plotted in the same figure and is calculated from equation (12), which is the product of (6) and (9).

$$B_d = \frac{P}{\Delta H_d + (\pi \cdot D \cdot N)^2} \dots(12)$$

Equation (12) tends to a maximum  $B_{dmax}=P/\Delta H_d$  as the frequency  $N$  tends to zero and is calculated to be 21,6 ton/h. The difference between the crusher throughput and the rate of final product is the circulating load that is presented in the same Figure 3. In this figure, one should take into consideration the fact that the crusher feed rate is limited by the volume saturation of the crusher that cannot be filled by more than 100%. From equations (6), (7) and (8) one has equation (13) which shows the volume saturation  $f$  that is presented in Figure 4 as a function of the rotation frequency

$$f = \frac{P \cdot \ln(R/R_0)}{(2 \cdot \pi \cdot R \cdot N)^3 \cdot (\pi \cdot R \cdot h \cdot \rho)} \cdot 100 \dots(13)$$

In Figure 4 one can see that saturation increases as the rotation frequency decreases and for the present case it becomes 100% at a frequency 120 RPM, below which the crusher is full up and blocks. This means that Figure 3, and any other that gives a function of frequency, holds for frequencies above 120 RPM.

At this frequency although the maximum feed rate to the crusher can be 1095 ton/h the corresponding product rate is only 21.2 ton/h

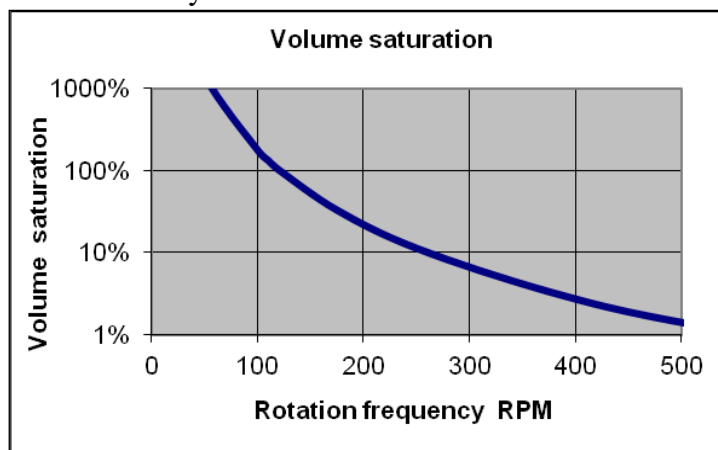

Figure 4: Volume fullness versus rotation frequency

Circulating load

It is already obvious from Figure 3 that the circulating load increases faster than the corresponding production rate. The ratio of circulating load to the production rate is presented in Figure 5.

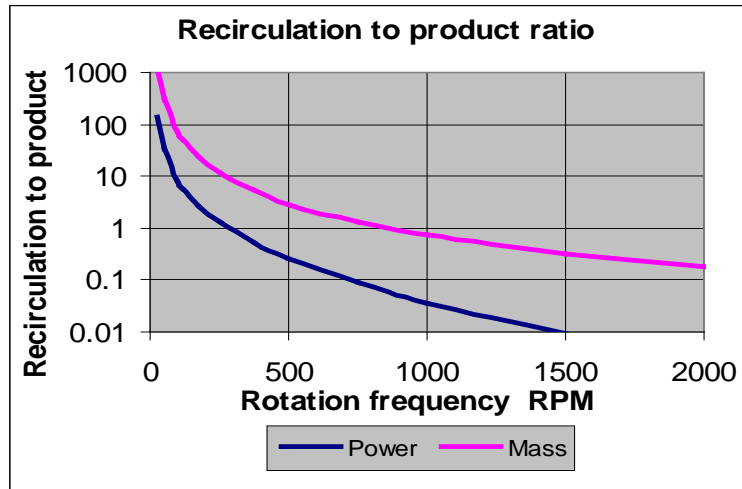

Figure 5: Circulating load to production ratio.

From this figure one can see that for the frequency 800 RPM the ratio is unit and the mass of circulating load is equal to the mass of the product. Above this frequency the circulating load is less than the product and below it increases quickly.

Energy cost

What is interesting from the point of view of economics and environmental impact is the energy cost per unit mass of the final product. Although, the production rate increases at low frequencies and the crushing cost decreases, however due to the increase of the circulating load the final cost of the product bears the cost of the increasing circulating load as well. The energy cost per mass of the product due to the crusher and the circulation of the material is presented separately in Figure 6 together with the sum of the two that is the total cost.

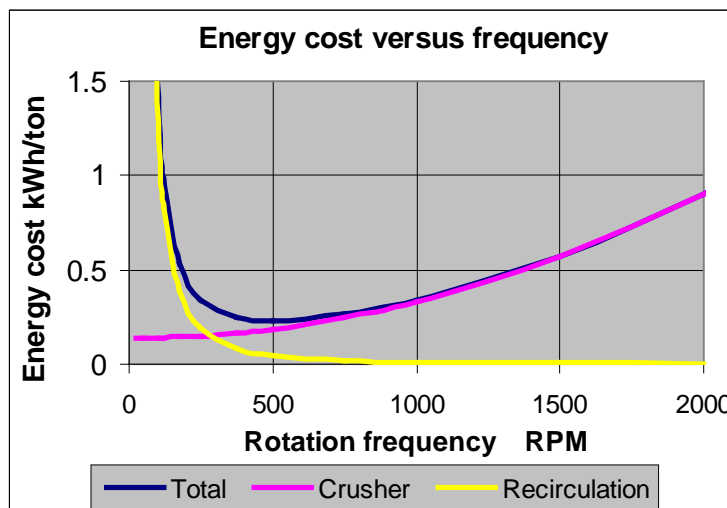

Figure 6: Energy cost versus rotation frequency

The energy cost for crushing increases with the frequency, while the cost for the circulation decreases. The sum of the two that is the final cost it has a minimum at 500 RPM, which shows the optimum conditions to run the system. The above optimum could not be derived without the knowledge and the understating of the unit process involved.



## Energy efficiency

Having defined the energy cost one can go a step further to examine the energy efficiency of the system and of the crusher as well. As explained, the energy is partly consumed for the operation of the crusher and partly for the circulation of the coarse fraction that did not break. The ratio of energy consumed for circulation to the one consumed for the crusher has been presented in Figure 5. At a frequency about 300 RPM the ratio is 1/1. At higher frequencies the system consumes more energy for crushing, while at lower ones most of the energy is consumed for the circulation.

The term *energy efficiency of the system* is defined as, the ratio of the energy actually consumed by the crusher to the total energy consumed by the system, and is presented in Figure 7 versus the rotation frequency. At high frequencies the energy is mainly consumed by the crusher and the efficiency of the system is high as well.

The term *energy efficiency of the crusher* is defined as, the ratio of the theoretical energy  $\Delta H_d$  required for crushing to the actual energy consumed by the crusher per mass of its product, and is also presented in Figure 7.

The multiplication of the energy efficiency of the system times the energy efficiency of the crusher gives the *total energy efficiency*, which is the ratio of the theoretically energy required for crushing, to overcome the coherence of the material, to the total energy consumed by the system.

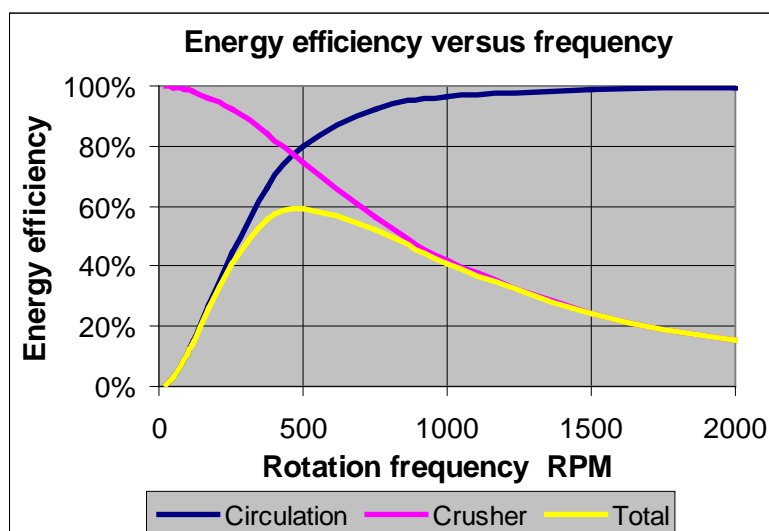

Figure 7: Energy efficiency

The total energy efficiency is also presented in Figure 7 and gives a maximum at a rotation frequency 500 RPM which is the same at which the energy cost of the system has a minimum, as shown in the previous Figure 6. The maximum of the total energy efficiency is about 60% and shows an excellent performance, in contrast to the existing impression which says that the energy efficiency of size reduction systems is far lower.

## Discussion and conclusions

An assumption made throughout the present work is that all the equipment used consume energy only for the physical work they perform and no energy is lost for friction. The energy required for crushing and circulation of the material has been calculated using this assumption. In the next step this work takes into consideration the crushing model that determines the mass fraction of the crusher feed that breaks below the desired size as a function of the rotation frequency of the crusher disc. This frequency determines the kinetic energy that the particles acquire for crushing.

For a given power of the crusher motor its throughput capacity depends on the kinetic energy given to the particle and is inversely proportional to it. The lower the energy given to

the particles, the higher the throughput capacity, up to the point the crusher blocks. However the lower the energy given to the particles the greater the mass fraction of the material that has to be recycled.

This work also indicates the optimum rotation frequency at which the final energy cost in kWh/ton of product is at a minimum, and for the case studied it is at 500 RPM. Finally the work shows that this optimum coincides with the calculated rotation frequency that gives the optimum energy efficiency. According to the crushing model the specific energy required is 0,139 kWh/ton, while the analysis of the system shows that at the optimum frequency they specific energy actually required is 0,23 kWh/ton, giving an energy efficiency 60%. The calculated efficiency 60% does not agree to the prevailing impression that crushing efficiency is one digit number %.

As already mentioned this work assumes that the equipment used are perfect and do not consume friction energy. The mechanical losses of the system are not in the scope of the present work and their calculation is left as a further work to the readers. However by experience one could say that the mechanical energy losses due to friction and the electrical energy losses due to  $\cos(\varphi)$ , power factor, do not exceed 50% of the total energy. This means that even taking into consideration the mechanical losses the final energy efficiency is better than 30% relative to to calculated number 60%.

Taking the case study presented as an example one could calculate the optimum efficiency and energy cost for any closed crushing system. The only extra thing required is the mathematical model that gives the relationship between the particle size and the theoretical energy required to break it below its size class.

#### **References:**

D. Stamboliadis, "Design of a centrifugal crusher for minerals, based on the design of structures", undergraduate thesis, Technological Education Institute of Piraeus, Greece. (2013) (in Greek)

Elias Stamboliadis, Dimitris Stamboliadis, Kyriaki Kiskira , Chukwudubem Emejulu, "Crushing of mineral particles by control of their kinetic energy" Scientific Journal of Riga Technical University, series 1, Material Science and Applied Chemistry, RTU Press, 2013, N 28. ISSN 1407-7353 print, ISSN 2255-8713 online.

Daphne Manoussaki, Assistant Professor of Applied Mathematics, personal communication, Technical University of Crete, May 2013

Elias Stamboliadis "A novel process for the study of breakage energy versus particle size", Geomaterials, ID: 1110054, Vol.3, No 3, 2013.

# THEORETICAL AND PRACTICAL CONSIDERATIONS ON SOME OF THE DIFFUSION ASPECTS IN THE PRESENCE OF MECHANICAL VIBRATIONS

*Lecturer PhD. Eng. Stoicanescu Maria*  
Transilvania University of Brasov, Romania

---

## Abstract

This paper presents some considerations regarding the diffusion processes which occur during the sulphocyanurizing of high speed steels in vibratory field. The mechanical vibrations which are introduced into the metallic material contribute to a increase of the thermochemical treatment efficiency due to the elastic deformations of the basic crystalline grid. Therefore, there are obtained harder layers and the treatment duration is significantly shortened.

---

**Keywords:** Vibratory field, diffusion, termochemical treatment

## Introduction:

The thermochemical processes are generally characterized by relatively long periods of maintenance compared to the conventional heat treatments. In order to increase their efficiency the efforts are outstanding, along with the use of new technologies and materials.

Due to a series of experimental tests it was found that subjecting pieces to mechanical vibrations has as first effect the increasing of the diffusion speed. The hardness, the layer compactness and the fatigue resistance of tools and pieces also increase

Besides the effects on the active environment of the thermochemical treatment, the vibrations also have a stimulating effect on the crystalline grid of the metal. Below are highlighted some aspects of this problem.

## Theoretical considerations

The cc iron has in its unit cell two types of vacancies that can be occupied by diffusion atoms in order to form interstitial solid solutions.

These were the coordinates  $(0, 1/2, 0)$  and  $(1/2, 1/2, 0)$ , shown in Figure 1 and indicated with  $a_1$  and  $a_2$ .

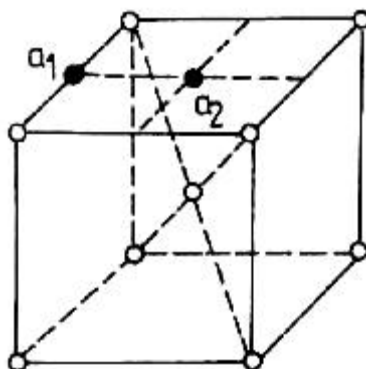

Fig. 1. possible positions to be occupied by foreign atoms in the unit cell of  $\alpha$  iron

Taking into consideration the unit cell dimensions of iron, it was calculated that the radius of the sphere that can be introduced into the  $a_1$ -type interstices is  $r_1$ , and of the one that can be introduced in the  $a_2$ -type interstices is  $r_2$ .

Table 1. Shows the values of these sizes and the atomic radiuses of the diffusion elements, carbon and nitrogen.

Table 1. The values of these sizes and the atomic radiuses of the diffusion element

$r_1$ [Å]	$r_2$ [Å]	Atomic radiuses		Ionic radiuses	
		Rc [Å]	R <sub>N</sub> [Å]	Rc <sup>4+</sup> [Å]	R <sub>N5+</sub> [Å]
0,19	0,36	0,80	0,70	0,18	0,13

Comparing the values from the table above it is shown that the penetration of the carbon or nitrogen atoms in the unit cell of the iron is accompanied by a deformation of the crystalline grid. In a crystal which is under no tension the foreign atoms can evenly occupy the places of type  $a_1$  and  $a_2$ . Through the diffusion process, these atoms jump from one interstitial position to another with the time of standing in position which is equal in all cases.

If the crystalline grid is subjected to a tensile stress (in the elastic field) on one direction ie x, the distribution of foreign atoms is disturbed because the the interstices increase on the direction x and on directions y and z decrease. Therefore, the time of standing changes on each of the 3 directions.

Submitting the crystalline grid to a variable stress of sinusoidal type, with period T, there can be imagined the following situations:

- 1)  $\tau \gg T$ : the oscillations period is small compared to the time of standing %, thus the foreign atoms cannot jump in a position favored by the variable stress as these positions become non-favored before being occupied through diffusion;
- 2)  $\tau \ll T$ : oscillations period is large compared to the time of standing, the atoms can pass through the favored places.

Between these two extremes, there is an optimal value for T, when the vast majority of foreign atoms succeed to jump from positions which become non-favored to the new favored ones.

In addition to the foregoing, the "elastic hysteresis" should be taken into account. It consists of the fact that after the stress cancellation the object keeps some residual deformation for a period of time even if the stress was applied in the elastic field, hence at low amplitudes of the deformation. The elastic hysteresis is due to an internal regrouping phenomena which propagates with a certain speed. If the hysteresis frequency is low, the deformations are considered instantaneous. Thus, at the diffusion stimulation in the crystalline grid of the iron the oscillations frequency has a low influence. Higher amplitudes can be used at low frequencies and require a lower energy consumption compared to the those at high frequencies. The oscillator power, at the frequency of 50Hz is effectively used both to activate the bath and stimulate the diffusion in the crystalline grid of steels.

### Experimental attempts and results

Samples of Rp5 speed steel were subjected to sulphocyanurizing thermochemical treatment after hardening and two consecutive annealings. The sulphocyanurizing treatment took place concurrently with a third annealing at its temperature according to Table 2. A series of samples was treated in the absence of the energetic field, and the second one in its presence. The mechanical vibrations were directly transmitted to the samples which were to be treated.

Table 2. Applied treatments

Material type	Heat treatment		Thermochemical treatment	
	Hardening	Annealing	Usual	Simulated
Rp5	1190 [°C], oil	560[°C ], 2x1h	560[°C] 20, 40 and 60min	560[°C]; 50Hz; 20, 40 and 60 min

The samples obtained according to the diagram above were processed in order to measure the hardness, the diffusion layer thickness and for the microstructure study (Table 3).

Table 3. Microhardness

Treatment type	Usual thermochemical treatment			Simulated thermochemical treatment		
	20 min	40min	60min	20min	40min	60min
Layer thickness [mm]	0,0150	0,0244	0,0330	0,0280	0,0415	0,0522
Microhardness [HV <sub>0.1</sub> ]	940	921	933	987	974	972

At the sulphocyanurizing treatment in vibrator field were obtained hardness values higher by 20 ... 40 units Vickers [HV<sub>0.1</sub>] in the diffusion area. Of course, under the influence of the vibrations, by the increase of the diffusion atoms penetration, there is a stronger stress of the crystalline grid. This leads to the increase of both the hardness and the fatigue resistance. Due to these effects, the wear resistance and the durability of the cutting tools increase considerably.

As for the diffusion proces, the thicknesses of the layers which were obtained in vibratory field increased considerably, compared to those obtained by usual procedure, with a equal maintaining duration.

In addition to the vibrations effects on the crystalline grid and facilitation of the addition atoms diffusion, they also stimulate the thermochemical process by:

- Homogenizing the salts bath;
- Activating the area situated close to the metallic surface;
- Preventing the deposits formation;
- Increasing the dissociation, etc..

The figures 2...7 present the microstructures of the samples which were obtained in different conditions of thermochemical treatment.



Fig.2 Rp5 steel after the usual sulphocyanurizing treatment, 20 min. Nital attack 1000:1

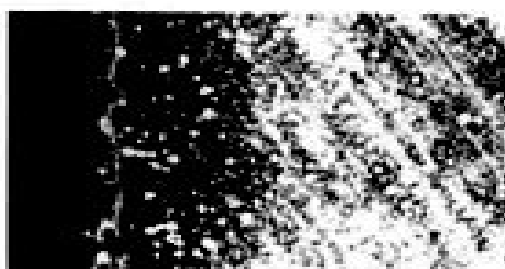

Fig.3 Rp5 steel after the sulphocyanurizing treatment in vibratory field, 20 min. Nital attack 1000:1

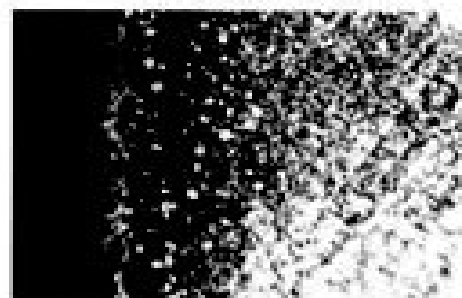

Fig.4 Rp5 steel after the usual sulphocyanurizing treatment, 30 min. Nital attack 1000:1



Fig.5 Rp5 steel after the sulphocyanurizing treatment in vibratory field, 30 min. Nital attack 1000:1

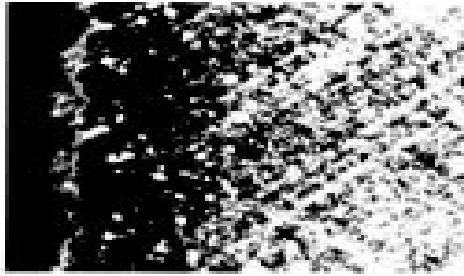

Fig.6 Rp5 steel after the usual sulphocyanurizing treatment, 40 min. Nital attack 1000:1

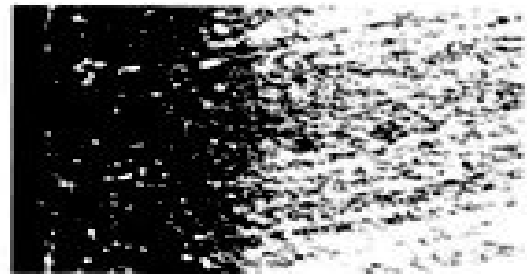

Fig.7 Rp5 steel after the sulphocyanurizing treatment in vibratory field, 40 min. Nital attack 1000:1

From the micrographs it is found that the core structure consists of martensite with inclusions of primary and secondary carbides.

The diffusion layer consists of a dark mass of nitrogen martensite with inclusions of primary and secondary carbides, as well as inclusions of carbonitrides and uniformly distributed fine sulfides. Sometimes, on the surface is found the appearance of the white layer (the combinations area) made by a agglomeration of defined compounds (sulfides, carbonitrides).

### Conclusion:

The diffusion processes of the thermochemical treatments can be substantially accelerated by applying energetic fields. Mechanical vibrations can be applied on the active (liquid) environment or the metallic material. It was proved that the most effective application was directly on the pieces which were to be treated. In this case, the active medium is also stimulated, particularly the one close to the pieces surface.

In addition to the increasing of the diffusion coefficient value, there is also obtained the increasing of the layers hardnesses, with effects on the wear and fatigue resistances

### References:

- Giacomelli, Ioan, Șerban, Cornel: Thermic and thermochemical heat treatment nonconventional methods. EVIEC VIII Ben Gurion University, Israel, 1997.
- Giacomelli, Ioan, Druga, Leontin, Samoila, Cornel, Bot, Dumitru: Unconventional technologies with solid state phase transformations. Editura Lux- Libris, 2000.
- Vermesan Gheorghe, and col. - Special heat treatment processes. Cluj - Napoca, 1990
- Pogodina-Alekseeva, K.M., Biront, V.S., Slavin, L.D.: Effect of ultrasonic vibration on the mechanical properties of R18 steel, Metal Science and Heat Treatment, ISSN: 0026-0673
- K. J. L. Iyer: Enhanced activity of austenite resulting from ultrasonic vibration in a low alloy case-hardened steel: Journal of Materials Science, ISSN: 0022-2461

# SIMPLE REGRESSION MODELS FOR PREDICTING SOIL HYDROLYTIC ACIDITY

*Zdenko Loncaric, PhD*  
*Vlado Kovacevic, PhD*  
*Domagoj Rastija, PhD*  
*Krunoslav Karalic, PhD*  
*Brigita Popovic, PhD*  
*Vladimir Ivezic, PhD*  
*Zoran Semialjac, B.Sc*

Josip Juraj Strossmayer University of Osijek, Faculty of Agriculture in Osijek, Croatia

---

## Abstract

Soil acidity is global factor limiting soil fertility of about 40% of the cultivable land which are acid. The common liming recommendations are based on different soil properties and therefore the calculation could differ according to available and used soil data. The aim of this paper was to determine the suitability of simple regression models for prediction soil hydrolytic acidity for precise liming recommendation using just actual ( $\text{pH}_{\text{H}_2\text{O}}$ ) and exchangeable soil pH ( $\text{pH}_{\text{KCl}}$ ) and humus content as basic soil data. These agrochemical analyses were done on basic set of 2600 soil samples and on validation set of 375 soil samples. The simple regression model could be accurate enough using just actual soil pH only for soils with lower humus content. Model accuracy increases including more soil data in prediction model, starting from adding soil exchangeable pH and then including humus data. Because of possible high soil sample variance, the best simple models are model including both actual and exchangeable soil pH, and humus, but with different regression equation for each range of soil pH or/and for each range of humus content. These kinds of models are sensitive to soil cation exchange capacity, humus content, texture and soil acidity, indicating that model adjustment to soil types could result in increasing model accuracy. The model error correlate to humus content and soil acidity, and the lowest model error were about 14% in average for soil  $\text{pH}_{\text{KCl}}$  4-5, and 16% for soil  $\text{pH}_{\text{KCl}} < 4$ .

---

**Keywords:** Soil acidity, cation exchange capacity, liming, soil texture

## Introduction:

Soil acidity is global factor limiting soil fertility, and acidification is a slow, continuous natural process resulting in acid soils being common in areas where soil development continued for long, geological periods of time and under climatic conditions which rainfall exceeds evapotranspiration (Rengel, 2002). Human activities may intensify and speed up the acidification process (Rastija, 2006), therefore about 40% of the cultivable land were acid. In Croatia, acid soils participate in 1.6 million ha (Bogunović et al., 1997), and Mesić et al. (2009) noted that 831.704 ha of agricultural land were acid. The widely accepted ameliorative measure for acid soils is liming with goal to increase soil pH. Radić (1989) published that the first written evidence of liming in Croatia is the report of unknown author (Anonymous, 1789), and Kovačević (1947) published handbook to promote liming. There are numerous data about liming effect on crop yields in the eastern Croatia (Kovacevic et al. 2003, 2008, 2009, Kovacevic and Rastija, 2010; Kovacevic et al., 2011). The influence of fertilization and

liming on soil properties were investigated by numerous authors (Bowszys et al., 2005; Hughes et al., 2004; Rahman et al., 2002; Zhang et al., 2004; Lončarić et al., 2005; Lončarić et al., 2007; Rastija et al., 2008; Popović et al., 2010). The soil adsorption complex plays an important part in soil formation and in the evolution and genesis of soils. Optimal composition of soil adsorption complex for arable crop production is 65 – 85 % Ca, 5 – 15 % Mg, 2 – 3,5 % K and with total content of basic cations above 85 % with at least 70 % Ca (Karalić et al., 2011). The total content of basic cations is much lower than optimum in all soils with excessive acidity. Common agrotechnical measure to neutralize excessive acidity is liming with material containing  $\text{Ca}^{2+}$  and/or  $\text{Mg}^{2+}$  cations. The determination of precise amount of liming material needed to neutralize acidity is very important since too high amounts result in unnecessary excessive production costs, and may result in lower availability of plant nutrients (phosphorus, iron, zinc). On the other hand, too low amounts are not effective enough and require additional application, that is additional costs.

The common liming recommendations are based on different soil properties and therefore the calculation could differ according to available and used soil data (Lončarić et al. (2005). Liming recommendations are made according to soil pH values, hydrolytic acidity and base saturation, what requires laboratory results of hydrolytic acidity and cation exchange capacity. However, common agrochemical analyses in soil laboratories in Croatia includes analyses of soil pH, humus content and plant available phosphorus and potassium. Hence, usually there aren't available data of hydrolytic acidity and cation exchange capacity for liming recommendations, but soil pH and humus content are providing much more information about cation exchange capacity and base saturation if there are used by model for prediction hydrolytic acidity. The aim of this paper was to determine the suitability of simple regression models for prediction of soil hydrolytic acidity and, therefore for precise liming recommendation using just soil pH, humus content and simple regression model.

### **Material and methods:**

Soil samples were collected in continental part (Pannonian basin) of Croatia. The topsoil layers of arable land were sampled using agrochemical probe on depth 0-30 cm after crop harvests (mainly after harvest of winter wheat, barley or rapeseed). During period 2010-2012 years 2600 soil samples were collected and analyzed as basic data set, and during year 2013 additional 375 soil samples were collected in a wider range of soil types as validation set.

The soil samples were prepared, dried (in a thermostatically controlled drying oven at a temperature of  $40^\circ \text{C} \pm 2^\circ \text{C}$ ), ground and stored for physicochemical analyses according to the ISO 11464 procedure (ISO, 1994a). The determination of soil pH was made in 1:5 (v/v) suspensions of soil in water ( $\text{pH}_{\text{H}_2\text{O}}$ ) and in a 1 M KCl solution ( $\text{pH}_{\text{KCl}}$ ) according to ISO 10390 (ISO, 1994b). Soil organic matter was determined by determination of organic carbon (C) by sulfochromic oxidation as prescribed by ISO 14235 (ISO, 1998). A correction factor of 1.724 was used to calculate organic matter from organic C. In addition, hydrolytic acidity was analyzed using soil extraction by Na-acetate. A statistical analysis of basic samples set (2600 samples) and validation set (375 samples) was performed by SAS Program for Windows (SAS Institute INC., Cary, NC, USA), and using Microsoft Excel 2010.

### **Results:**

The actual soil acidity of 2600 analyzed samples (Table 1) used for model were in the range of 2.57 pH units (4.06 to 6.63), very similar to the range of exchangeable acidity 2.63 pH units (from 3.41 to 6, 04). Soil samples represented all classes of soil humus content, ranging from very poor (0.33% humus), to soil rich in humus content (5.41% humus), with a wide range of hydrolytic acidity of soils, from soils where liming is not recommended (0.42 cmol/kg) to soils where liming is necessary agrotechnical measure for soil conditioning (9.14 cmol/kg).



Table 1. The agrochemical properties of 2600 soil samples used for regression model

Soil properties (Mark)	pH <sub>H2O</sub> (A)	pH <sub>KCl</sub> (S)	pH <sub>Diff.</sub> (A-S)	Humus (%) (H)	Hy (cmol/kg) (HA)
Minimum	4,06	3,41	0,52	0,33	0,42
Maksimum	6,63	6,04	1,79	5,41	9,14
Average	5,42	4,51	0,91	1,83	4,64

All developed regression models resulted in very significant correlations (Table 2) of predicted hydrolytic acidity and actual measured values. However, the lowest correlation was in cases when only one soil properties was incorporated into model, like pH<sub>H2O</sub> as actual soil acidity (model A<sub>2600</sub>) or pH<sub>KCl</sub> as exchangeable soil acidity (model S<sub>2600</sub>). The model errors (ME) in predicting hydrolytic soil acidity were in range 0 - 2,5 cmol/kg or in average 0,71 (15,3 %) for both, A<sub>2600</sub> and S<sub>2600</sub> models.

Using both soil data, actual and exchangeable soil acidity in the same model (model AS<sub>2600</sub>) resulted in ME decreasing for 0,08 units and average ME was 0,63 (13,6 %). Such decreasing of ME was expected since using actual and exchangeable soil acidity present additional information about cation exchange capacity (CEC) of soil. Namely, since hydrolytic acidity correlate to sum of all acid cations on soil adsorption complex represented mainly by clay particle and organic humus colloids, the difference between actual and exchangeable soil acidity could be connected to percentage of clay and organic particles in soils. Moreover, additional information about CEC was certainly humus content, therefore using information about humus content in model ASH<sub>2600</sub> (Table 2) resulted in further ME decreasing to 0,57 cmol/kg in average (12,3 %).

Table 2. Regression parameters (Y = Hydrolytic acidity = Intercept + AX1 + SX2 + HX3) and decrease of model error (ME) in cmol/kg based on the Y = I + AX relation

Model equation	r <sup>2</sup>	Intercept	pH <sub>H2O</sub> (A)	pH <sub>KCl</sub> (S)	Humus (%) (H)	ME decrease
A <sub>2600</sub>	0,646**	16,101	-2,11	-	-	0
S <sub>2600</sub>	0,634**	14,208	-	-2,12	-	0,01
AS <sub>2600</sub>	0,678**	15,593	-1,26	-0,91	-	0,08
ASH <sub>2600</sub>	0,707**	15,546	-1,37	-0,89	+0,285	0,09

Still, the model sensitivity on humus content was rather low, since humus content difference of 4 % (1,01% vs. 5,01%) resulted in increasing predicted hydrolytic acidity only 1,14 cmol/kg (7,52 – 6,38), presuming no changes in soil pH:

$$15,546 - 1,37 \times 4,57 (A) - 0,89 \times 3,59 (S) + 0,285 \times 1,01 (H) = 6,38 \text{ cmol/kg}$$

$$15,546 - 1,37 \times 4,57 (A) - 0,89 \times 3,59 (S) + 0,285 \times 5,01 (H) = 7,52 \text{ cmol/kg.}$$

Therefore a new data set was used for model validation. These set includes 375 soil samples with similar ranges of soil pH (Table 1 and Table 3), but with higher differences between soil pH<sub>H2O</sub> and pH<sub>KCl</sub> (pH<sub>H2O</sub> – pH<sub>KCl</sub> = pH<sub>Diff.</sub>), and with higher soil humus content (0,33-5,41 vs. 1,01-6,41, or in average 1,83 vs. 2,26) and higher hydrolytic acidity (up to 9,14 vs. up to 21,04).

Table 3. The chemical properties of 375 soil samples used for model validation

Soil properties (Mark)	pH <sub>H2O</sub> (A)	pH <sub>KCl</sub> (S)	pH <sub>Diff.</sub> (A-S)	Humus (%) (H)	Hy (cmol/kg) (HA)
Minimum	4,39	3,70	0,55	1,01	0,11
Maksimum	7,00	6,02	1,79	6,41	21,04
Average	5,89	4,65	1,24	2,26	4,80

The values of hydrolytic acidity (Hy) predicted by ASH<sub>2600</sub> model were in range 1,22 – 6,95 cmol/kg and measured values were in quite wider range 0,11 – 21,04. The model error was in average 1,11 cmol/kg, or 25,8%, what is significantly higher error than for basic data set with 2600 soil samples. The reason for so high ME was higher humus content in new data set than in basic data set, and as higher humus content was, the higher was ME (humus <2, 2-3, 3-4, >4 for ME 23, 22, 35 and 51%, respectively).

Also, the validation data set has higher standard error (5-fold), standard deviation (2-fold) and sample variance (3,5-fold) that basic data set for humus, and similar were data set comparison for pH difference ( $pH_{H_2O}-pH_{KCl}$ ) and measured hydrolytic acidity (Hy), but not for  $pH_{H_2O}$  and  $pH_{KCl}$  (Table 4).

Table 4. Standard error, standard deviation and sample variance for basic and validation data sets

Descriptive statistic	basic data set (2600 samples)			validation data set (375 samples)		
	humus	$pH_{H_2O}-pH_{KCl}$	Hy	humus	$pH_{H_2O}-pH_{KCl}$	Hy
standard error	0,0090	0,0033	0,026	0,0429	0,0121	0,128
standard deviation	0,4577	0,1662	1,320	0,8315	0,2352	2,483
sample variance	0,2095	0,0276	1,742	0,6913	0,0553	6,168

Considering all differences of data sets, model  $ASH_{2600}$  wasn't precise enough for prediction hydrolytic acidity in soils with higher hydrolytic acidity (Graph 1, Figures A and B) or higher humus content, or basically in all data sets with higher deviation or variance. Therefore new regression models were calculated using validation data set (Table 5).

The highest ME (30,9 and 27,6 %) was in models which include only  $pH_{H_2O}$  ( $A_{375}$  model) or  $pH_{KCl}$  ( $S_{375}$  model), but  $S_{375}$  model reduced ME 8,9% comparing  $A_{375}$  model. Next model improvement was including both pH data ( $AS_{375}$  model) with ME decreasing 11,2% comparing to  $A_{375}$  model. Finally, the best model for validation set was  $ASH_{375}$  model with all data ( $pH_{H_2O}$ ,  $pH_{KCl}$  and humus) with decreasing model error 33,3%. Model error was 20,9 % in average, with higher error for samples with higher humus content (>4 and 3-4%, ME was 22,9 and 25,5%, respectively), but correlation of predicted and measured hydrolytic acidity was very significant (Graph 1, Figure C).

Table 5. Regression parameters ( $Y = \text{Hydrolytic acidity} = \text{Intercept} + AX_1 + SX_2 + HX_3$ ) after validation and decrease of model error (ME) based on the  $Y = I + AX$  relation

Model equation	Intercept	$pH_{H_2O}$ (A)	$pH_{KCl}$ (S)	Humus (%) (H)	ME decrease	ME decrease (%)
$A_{375}$	20,356	-2,64	-	-	0	0
$S_{375}$	18,156	-	-2,87	-	0,12	8,9
$AS_{375}$	19,193	-0,61	-2,32	-	0,15	11,2
$ASH_{375}$	16,690	-0,47	-2,83	+1,786	0,45	33,3

However, further ME decreasing and model improvement, were made by splitting validation set into 4 groups according to soil  $pH_{KCl}$  (Table 6). Model errors in all 4 groups were decreased using  $ASH_{375pH}$  model comparing to  $ASH_{375}$  model. ME decreasing was 11,1% up to 44,2% (Table 6). This approach reduced ME for 375 samples in validation set on 16,7 % with lowest error with  $pH_{KCl}$  4-5 (ME 14,2%) and  $pH_{KCl} < 4$  (16,7%), and correlation of predicted and measured Hy was higher than for model  $ASH_{375}$  (Graph 1, Figure D).

Table 6. Regression parameters of  $ASH_{375pH}$  model after splitting samples into 5 groups according to soil pH

Model equation $pH_{KCl}$ range	Intercept	$pH_{H_2O}$ (A)	$pH_{KCl}$ (S)	Humus (%) (H)	ME decrease	ME decrease (%)
< 4,0	57,583	0,493	-15,232	+3,158	0,40	21,1
4,0-5,0	15,975	0,082	-3,366	+1,621	0,08	11,1
5,0-5,5	9,281	1,485	-2,969	+0,120	0,46	44,2
> 5,5	15,067	-0,885	-1,424	+0,095	0,23	30,7

The  $ASH_{375pH}$  model sensitivity on humus content is quite high and pH sensitive, since humus content difference of 4 % (1,01% vs. 5,01%) resulted in increasing predicted hydrolytic acidity for example 12,63 cmol/kg (20,97 – 8,34), presuming no changes in soil pH and if soil was very acid ( $pH_{KCl} < 4$ ):

$$57,583 + 0,493 \times 4,57 \text{ (A)} - 15,232 \times 3,59 \text{ (S)} + 3,158 \times 1,01 \text{ (H)} = 8,34 \text{ cmol/kg}$$

$$57,583 + 0,493 \times 4,57 \text{ (A)} - 15,232 \times 3,59 \text{ (S)} + 3,158 \times 5,01 \text{ (H)} = 20,97 \text{ cmol/kg.}$$

Simultaneously, if soil was slightly acid ( $pH_{KCl} > 5$ ), humus content difference of 4 % will resulted in increasing predicted hydrolytic acidity for example only 0,48 cmol/kg (3,23 – 2,75).

$$9,281 + 1,485 \times 5,70 (A) - 2,969 \times 5,09 (S) + 0,120 \times 1,01 (H) = 2,75 \text{ cmol/kg}$$

$$9,281 + 1,485 \times 5,70 (A) - 2,969 \times 5,09 (S) + 0,120 \times 5,01 (H) = 3,23 \text{ cmol/kg.}$$

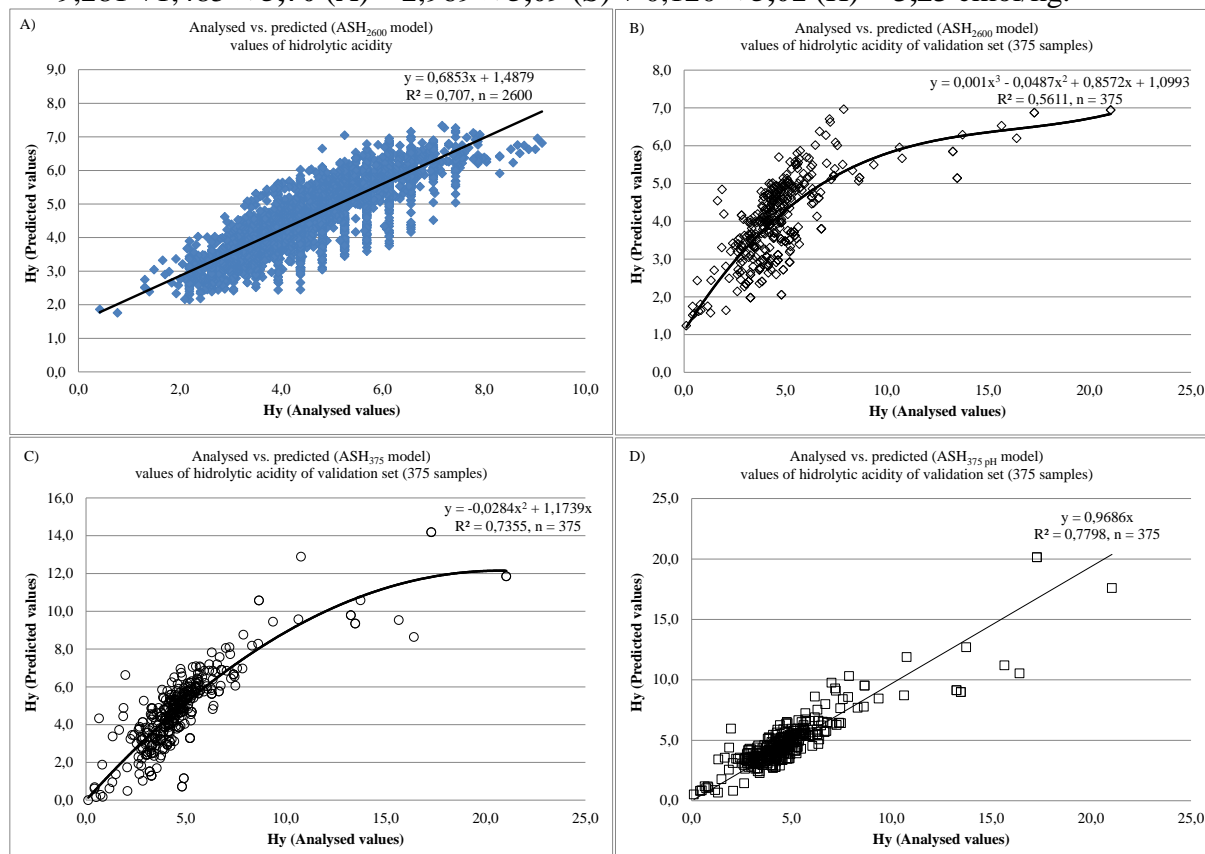

Graph 1. Regression of measured (analytical) and predicted (model) hydrolytic acidity for: A) prediction model  $ASH_{2600}$  for 2600 samples, B) the same  $ASH_{2600}$  model for new validation set of 375 samples, C) corrected prediction model  $ASH_{375}$  after model validation, D) prediction model  $ASH_{375}$  corrected for four different class of soil pH

## Conclusion:

Basic agrochemical soil data (actual and exchangeable soil pH, and humus) could be enough for prediction of soil hydrolytic acidity using simple regression model. The simple regression model could be accurate enough using just actual soil pH only for soils with lower humus content. Model accuracy increases including more soil data in prediction model, starting from adding soil exchangeable pH and then including humus data. Because of possible high soil sample variance, the best simple models are model including actual and exchangeable soil pH, and humus, but with different regression equation for each range of soil pH or/and for each range of humus content. These kinds of models are sensitive to soil cation exchange capacity, humus content, texture and soil acidity, indicating that model adjustment to soil types could result in increasing model accuracy. The model error correlate to humus content and soil acidity, and the lowest model error were about 14% in average for soil  $pH_{KCl}$  4-5, and 16% for soil  $pH_{KCl} < 4$ .

## References:

- Anonymous (1789): Pridavak od gjubrenja s krecsom. In: "Ubavistenje od lana i konoplje opravlanja za poljodilce" Pretiskano slovima Kraljevske mudroskupstine, Budim. 29-34.
- Bogunovic M., Vidacek Ž., Racz Z., Husnjak S., Sraka M. (1997): Namjenska pedološka karta Republike Hrvatske i njena uporaba. Zagreb, Agronomski glasnik 5 –6.
- Bowszys, T., Ruszkowski K., Bobrzecka D., Wierzbowska J. (2005): The effects of liming and complete fertilizers application on soil pH and content of some heavy metals in soil. Journal of Elementology, 10: 33-40.

- Hughes, B., Payne, R., Hannam., B.: Soil acidity and the benefits of liming. The department of Primary Industries and Resources South Australia, 2004.
- ISO (1994a): International Standard Organisation, [ISO 11464: 1994 (E)] Soil quality – pretreatment of samples for physico-chemical analyses.
- ISO (1994b): International Standard Organisation, [ISO 10390: 1994 (E)] Soil quality – determination of pH.
- ISO (1998): International Standard Organisation, [ISO 14235: 1998 (E)] (1998) Soil quality – determination of organic carbon by sulfochromic oxidation.
- Karalić, K., Lončarić, Z., Popović, B., Kovačević, V., Kerovec, D. (2011): Evaluation of liming and extraction method impact on exchangeable cations determination. Proceedings of International Conference Soil, Plant and Food Interactions. Škarpa, P. (ur.). Brno. Faculty of Agronomy, Mendel University in Brno, 2011: 158-165.
- Kovačević, P. (1947): Vapno kao gnojivo. Zagreb. Poljoprivredni nakladni zavod. 1947.
- Kovačević, V., Bertić, B., and Grgić, D. (1993): Response of maize, barley, wheat and soybean to liming on acid soils. *Rostlinna Vyroba* 39: 41-52.
- Kovačević, V., Komljenović, I., Marković, M. (2003): Uloga kalcizacije u povećanju prinosa ratarskih kultura. *Banja Luka, Agroznanje*, 226-238.
- Kovačević, V., Lončarić, Z., Šimić, D., Rastija, D., Rastija, M. (2008): Influences of liming on field crop yields in eastern Croatia. *Ist Scientific Agronomic Days Devoted to 90-th birthday of Dr.h.c., prof. Ing. Emil Špaldon, DrSc., Nitra, Slovak Republic*, 2008.
- Kovačević, V., Banaj, D., Brkić, I., Šimić, D. (2009): Impacts of liming on yields of field crops. *International Commission of Agricultural and Biological Engineers, Section V. Conference "Technology and Management to Increase the Efficiency in Sustainable Agricultural Systems"*, Rosario, Argentina, 2009.
- Kovačević, V., Rastija, M. (2010): Impacts of liming by dolomite on the maize and barley grain yields, *Poljoprivreda* , 16 (2): 3-8.
- Kovačević, V., Šimić, D., Kadar, I., Knežević, D., Lončarić, Z. (2011): Genotype and liming effects on cadmium concentration in maize. *Genetika* 43: 607-615.
- Lončarić, Z., Karalić, K., Vukadinović, V., Bertić, B., Kovačević, V. (2005): Variation of liming recommendation caused by calculation approach. *Plant nutrition for food security, human and environmental protection. Fifteenth International Plant Nutrition Colloquium. C.J.Li et al.(ed). Beijing. China. Tsinghua University Press. 1042-1043.*
- Lončarić, Z., Rastija, D., Karalić, K., Popović, B. (2006): Mineral fertilization and liming impact on maize and wheat yield. *Cereal Research Communications*. 34: 717-720.
- Lončarić, Z., Popović, B., Karalić, K., Rastija, D., Engler, M. (2007): Phosphorus fertilization and liming impact on soil properties. *Cereal Research Communications*. 35: 733-736.
- Mesić, M., Husnjak, S., Bašić, F., Kisić, I., Gašpar, I. (2009): Suvišna kiselost tla kao negativni čimbenik razvitka poljoprivrede u Hrvatskoj. In: *Proceedings of 44th Croatian and 4th International Symposium on Agriculture, Marić, S. and Lončarić, Z., Editors.*, Osijek; Faculty of Agriculture in Osijek, 9-18.
- Popović, B., Lončarić, Z., Rastija, D., Karalić, K., Iljkić, D. (2010): Ameliorative PK-fertilization and liming impacts on soil status. *Növénytermelés*. 59 (Suppl. 2): 9-12.
- Radić, Lj. (1989): Jubilej - 200 godina brošure "Ubavistenje od lana i konoplje opravljnja za poljodilce" s prilogom o kalcizaciji. *Znanost i praksa u poljoprivredi i prerhrambenoj tehnologiji* 19: 260-266.
- Rahman, M.A., Meisner, C.A., Duxbury, J.M., Lauren, J., Hossain., A.B.S. (2002): Yield response and change in soil nutrient availability by application of lime, fertilizer and micronutrients in an acidic soil in a rice-wheat cropping system. In: *Proceedings 17<sup>th</sup> WCSS Symposium Thailand. no. 5. 773: 1-7.*

Rastija, Domagoj. Soil moisture regime and maize and winter wheat yields on limed acid soil. Dissertation. Josip Juraj Strossmaayer University of Osijek. Faculty of Agriculture in Osijek, 2006.

Rastija, D., Lončarić, Z., Karalić, K., Bensa, A. (2008): Liming and fertilization impact on nutrient status in acid soil. *Cereal Research Communications*. 36: 339-342.

Rengel, Zdenko, ed. *Handbook of Plant Growth. pH as the master Variable*. New York, Basel. Marcel Dekker, Inc., 2002.

Zhang, H., Edvards, J., Carver, B., Raun., B.: *Managing Acid Soils for Wheat Production*. Oklahoma Cooperative Extension Service. 2004.

# EXPERIMENTAL AND CALCULATION-BASED FORECASTING OF FUEL CONSUMPTION ON ZINC- BEARING SLAG PROCESSING UNIT BASED ON PHASE INVERSION REACTOR

*B. Dikhanbayev*

*K. Baubekov*

*A. Dikhanbayev*

Kazakhstan, Astana, Agrotechnical University named after S. Seyfullin

---

## Abstract

Using the affine (related) modeling, which foresees, based on test data of pilot plant, the necessity of correct calculation of conditional sample, is performed recalculation of pilot plant's test results on industrial sample. Having defined more precisely in mathematical description of process collection accountable factors, the list of basic numbers of similarity were obtained, on the basis of which is developed new technique of calculated estimation of fuel consumption in industrial sample of pilot plant. As a result of calculations it is shown that in comparison with fuming-furnace processing the liquid slag, on industrial sample of pilot plant the consumption of natural gas will be in two times lower, and with the increase of installation output in the range (5-25) t/h the specific consumption of natural gas will reduce in ~1,5 times.

---

**Keywords:** Fuel consumption, phase inversion reactor

When developing high-temperature processes and equipment based on new technological ideas, the researcher often has to answer the following question:

- how should the "cold model" data, calculated on the basis of a number of assumptions, be transferred onto the pilot installation;
- how should the results of complex and labor-intensive pilot tests be transferred onto the future industrial equipment without excessive risk.

The method of similar physical analogs that requires mathematical description of the studied processes and its subsequent analyses by using similarity theory methods is used in practice for determining the basic parameters of the pilot installation, thereby answering the first question.

However, while satisfying the most stringent stipulations of the modeling process, this method leaves unanswered one or more similarity requirements, such as regarding losses into the environment, composition of the oxidant, etc. Therefore, a strictly similar implementation of the pilot installation based upon "cold" model testing is very approximate, albeit necessary.

To answer the second question, Prof. A.D. Klyutchnikov proposed the method of affine physical models. According to [1], this method, just as the method of similar models, requires recalculation of the model's evaluation data for parity of uniform similarity criteria to the sample that is similar to the given model. But this sample, denoted as provisory, together with the model, belongs to the affine series related to the forecasted sample and may have uncorrelatable calculated parameters. Therefore, the affine model method requires calculated correction of the provisory sample to align its individual parameters with the proposed operating conditions of the sample under consideration. For example, in a pilot installation

with 2 t/hr capacity, at  $a = 0.8$ , the ratio of reducing gases ( $\text{CO}$ ,  $\text{H}_2$ ) to the reducible elements ( $\text{Fe}_3\text{O}_4$ ,  $\text{ZnO}$ ) is  $(y+q)/(f+z)=3$ .

To comply with similarity condition to the sample, i.e.  $(y+q)/(f+z)=idem$ , for a 12 ton sample, the air consumption coefficient must be  $\alpha = 0.7$ .

Based on the similarity criteria, let's recalculate the actual data from the 2 ton model to the 12 ton provisory sample. After that, we shall calculate a fuel consumption correction for the provisory sample based on the dissimilarity of coefficient  $a$  between this provisory sample and the proposed 12 ton sample. We shall apply the corrected data to evaluate the parameters of the forecasted sample.

The waste slag processing unit is comprised of three main elements: inverted phase reactor, short rotary furnace, and high-temperature air heater. The reactor's effluent gases are used for preheating the waste slag and the blast air. The central element of the installation is the reactor that operates on a new technological principle - the phase inversion layer.

To build the "cold" reactor model, an evaluation methodology was developed for zinc reduction from slag in a phase inversion layer based on principles presented in [2]. Using this methodology and the test results of the gas-liquid reactor model we derived the following calculation path for reactor parameters of the pilot installation.

### 1. Data for calculations

Similarity criteria  $W_C/W_{np}=12-25$ ;  $I_C/G_B=0,09-0,19$ , velocity of the gases in the nozzle array -  $W_c$ , temperature of the molten layer -  $t_p$ , temperature of the gases at the entry into the nozzle array and in the phase inversion layer -  $t_c$ ,  $t_{np}$ , oxidant consumption coefficient -  $\alpha$ , initial and final concentration of zinc in slag -  $C_H^{Zn}$ ,  $C_K^{Zn}$ , number of nozzles -  $n_c$  and nozzle diameter  $d_c$  in the nozzle array. Here,  $W_{np}$  - normalized gas velocity within the phase inversion layer,  $I_c=m_\Gamma \cdot W_c$  - kinetic momentum of the gas at the entry into the nozzles,  $m_\Gamma$  - mass flow rate of the gas at the entry into the nozzles,  $G_B=M_B \cdot g$  - weight of the molten layer,  $M_B$  - mass of the bath layer,  $g$  - acceleration of gravity.

### 2. Natural gas consumption in the reactor

$$B = \frac{3600 \cdot W_C \cdot n_C \cdot 0,785 \cdot d_C^2}{(1 + \alpha v_B^0) \beta_C}, \text{ here } v_B^0 - \text{specific consumption of air for complete}$$

combustion of the natural gas,  $\beta_c$  - temperature coefficient of gas expansion before the nozzle array (in the combustion chamber).

**3. Relative expansion of phase inversion layer** is calculated by using the experimentally derived [3] formula that is valid within the variability range of  $W_C/W_{np}=6-75$ ,  $I_C/G_B=0,015-0,35$ .  $H/h_0=9,65(I_C/G_B)^{0,26}(W_C/W_{np})^{-0,19}$ , where  $H$ -height of the expanded molten layer. The height of the "undisturbed" molten layer  $h_0=M_B/\rho_p \cdot F_{np}$ , where  $\rho_p$ - melt density.

The normalized phase inversion area  $F_{np} = \frac{B(D+z)\beta_{np}}{3600 \cdot W_{np}}$  [1], where  $\beta_{np}$  - temperature

coefficient of gas expansion inside the phase inversion layer.  $(D+z)$  -total specific volume of gases developed inside the layer.

### 4. Gas content of the layer $\varphi=1-h_0/H$

**5. Time for complete mixing of the melt,  $\tau_{nep}$** , after introduction of a single concentration disturbance into the molten layer can be calculated by using the formula derived in [4] a valid within the ranges of

$$W_C/W_{np}=12-25, I_C/G_B=0,09-0,19:$$

$$H_0 = \tau_{nep} \cdot g / W_C = 0,07 (I_C / G_B)^{-0,6837} (W_C / W_{np})^{0,0859},$$

here  $H_0$  - homochromy criterion.

**6. Equivalent diameter of a molten particle within the layer,  $d_{\text{э}}$ , can be calculated by using the equation derived in [5]:**

$$\varphi = \left[ \frac{\frac{W_{np} d_{\text{э}}}{v_{\Gamma} C^n} + 0,02 C^n \left[ \frac{W_{np} d_{\text{э}}}{v_{\Gamma} C^n} \right]^2}{1 + 0,02 C^n} \right]^{0,21},$$

here, the equation coefficients have the following values:

$$C = \left( \frac{A}{B} d_{\text{э}}^3, A = g \rho_P / v_{\Gamma}^2 \rho_{\Gamma} \text{ for } \text{Re}_{\text{sum}} > 300 \text{ n}=0,5; B=1,21. \right.$$

The approximate velocity of an individual particle movement can be calculated by using formula [6]:

$$\text{Re}_{\text{sum}} = Ar / (18 + 0,6 \sqrt{Ar}), W_{\text{sum}} = \frac{\text{Re}_{\text{sum}} \cdot v_{\Gamma}}{d_{\text{э}}} \text{ where } \rho_{\Gamma}, v_{\Gamma} \text{ are the density and}$$

kinematic viscosity of the gas.

### 7. Number of collisions between particles with concentration

$C_{\text{K}}^{\text{Zn}} > C_{\text{H}}^{\text{Zn}}$  that are entering the layer and particles in the layer, having a concentration of  $C_{\text{K}}^{\text{Zn}} < C_{\text{H}}^{\text{Zn}}$ , until reaching the desired equilibrium concentration of  $C_{\text{K}}^{\text{Zn}}$  in the layer [2]:

$$n = 1,443 X, \quad (2)$$

$$\theta = 1 - 3,385 \cdot A^{0,5} \cdot X^{-0,5} + 3AX^{-1}, \quad (3)$$

$$A = \frac{4D_{\text{ZnO}} \cdot \tau_{nep}}{1,443 \cdot d_{\text{э}}^2}, \quad (4)$$

$$X = \ln \frac{C_{\text{H}}^{\text{Zn}} - C_{\text{K}}^{\text{Zn}} \theta}{C_{\text{K}}^{\text{Zn}} (1 - \theta)}, \quad (5)$$

here,  $\theta$  - average, dimensionless concentration of ZnO through the volume of the particle.  $D_{\text{ZnO}}$  - coefficient of zinc oxide molecular diffusion toward the surface of the particle.

Simultaneous solution of equations (3), (4), and (5) yields  $\theta$  and then  $n$ .

### 8. Zinc sublimation time from the melt:

$$\tau_{\text{э03}} = \frac{\tau_{nep} (C_{\text{H}}^{\text{Zn}} - C_{\text{K}}^{\text{Zn}})}{n \cdot C_{\text{K}}^{\text{Zn}} (1 - \theta)}.$$

9. Reactor productivity in terms of slag:

$$P_{\text{ul}} = \frac{3600 \cdot M_{\text{e}}}{\tau_{\text{э03}}}$$

### 10. Based on the calculated data, we can determine the geometric parameters of the pilot installation.

However, comparative data show that the results of experiments on the pilot installation (the sample) differ in productivity in terms of slag by more than 30% from the calculated values that were based on the gas/liquid model testing data. As indicated above, this is



promoted by a number of unaccounted requirements of model similarity to the sample, such as high concentration of zinc ferrite  $ZnFe_2O_4$  and magnetite  $Fe_3O_4$  that are fed into the reactor from the rotary furnace (RF) as a result of slag overoxidation caused by air leakage into the RF or by worsening of the reducing atmosphere in the reactor due to oxygen carried in with the slag charging process, etc.

After broadening and refining the totality of considered factors in the mathematical description of processes that occur in reactor of the pilot installation and having performed the appropriate conversions of the simultaneous equations and the boundary conditions, we obtain the list of main similarity criteria for the thermal operation of phase inversion reactor (PIR).

When the thermal operation of pilot installation PIR (the model) is similar to the production sample PIR, they will show the following similarity criteria.

### 1. Geometric similarity

$$H/h_0 = idem, D_{o\phi}/d_{\phi bx} = idem \quad (6)$$

### 2. Aero- and hydrodynamic similarity.

$$W_C/W_{np} = idem, W_C = idem$$

$$\tau_{nep} \cdot g/W_C = idem \quad (7)$$

### 3. Similarity in specific productivity

$$\frac{p_v \cdot q_{nol} \cdot V^{CH\Phi}}{B \cdot (D+z) \cdot C_{oz} t_{oz}} = idem \quad (8)$$

### 4. Thermal load similarity.

$$\frac{q_{OC} \cdot F_{OC}}{B \cdot (D+z) \cdot C_{oz} t_{oz}} = idem \quad (9)$$

### 5. Technological process similarity

$$(y+q)/(z+f) = idem$$

$$\frac{\Delta C_Z}{C_Z} = idem, \frac{\Delta C_f}{C_f} = idem, \frac{q_{\text{энд}}}{C_{oz} t_{oz}} = idem, \frac{q_{nl}}{C_{oz} t_{oz}} = idem, \quad (10)$$

$$\frac{t_w}{t_{oz}} = idem, \frac{t_p}{t_{oz}} = idem, \frac{t_{nl}}{t_{oz}} = idem$$

Here,  $D_{\phi}$ ,  $d_{\phi bx}$  – diameters of the cyclonic section and the gas outlet port of the reactor,  $p_v$  – specific productivity of PIR,  $q_{nol}$  – productively used heat energy in reactor,  $V^{CH\Phi}$  – volume occupied by phase inversion layer,  $C_{oz}$ ,  $t_{oz}$  – specific heat and temperature of exhaust gases,  $q_{OC}$  – average heat density across the PIR lining,  $F_{OC}$  – PIR hot surface,  $y$ ,  $q$ ,  $f$ ,  $z$  – number of moles of CO,  $H_2$ ,  $Fe_3O_4$ , and ZnO taking part in reduction, per mole of natural gas,  $\Delta C_f$ ,  $\Delta C_Z$  – part of  $Fe_3O_4$  and ZnO reduced during the process,  $C_f$ ,  $C_Z$  – initial concentration of  $Fe_3O_4$  and ZnO in granulated slag,  $q_{\text{энд}}$  – average specific endothermic effect of  $Fe_3O_4$  and ZnO reduction,  $q_{nl}$  – specific heat of slag melting,  $c_w$  – specific heat of molten slag,  $t_w$ ,  $t_p$  – slag feed and molten slag temperatures,  $t_{nl}$  – slag melting temperature.

Based on the evaluated similarity conditions between the model and the sample, we can calculate the sample parameters in the following sequence.

1. Having set an arbitrary value "B" for natural gas consumption in the process, we can determine the composition of exhaust gases by using formula [7]:

$$(K-1)x^2 + [K(B_C + C_{H_2} - 2E_{O_2} - z - 4f) + 2E_{O_2} + z + 4f]x - B_C(2E_{O_2} - B_C + z + 4f) = 0,$$

$$z = \frac{P_w \Delta C_Z \cdot 22,4}{81 \cdot B}, f = \frac{P_w \Delta C_f \cdot 22,4}{232 \cdot B}, y = B_C - x$$

$$w = 2E_{O_2} - B_C - x - z - 4f, q = C_{H_2} - w, D = A_{N_2} + B_C + C_{H_2},$$

$$Zn^{\Gamma} = \frac{z}{D+z}, CO = \frac{y}{D+z}, H_2 = \frac{q}{D+z} \quad (11)$$

Here,  $K$  - equilibrium constant of  $CO_2 + H_2 \leftrightarrow CO + H_2O$ , reaction,  $x$ ,  $w$ -number of moles of  $CO_2$  and  $H_2O$ , respectively, per 1 mole of natural gas.  $A_{N_2}, B_C, C_{H_2}$  respective number of moles of nitrogen, carbon, and hydrogen that took part in the process, per 1 mole of natural gas,  $CO, H_2, Zn^I$  - absolute shares of these components in the exhaust gas.

2. The unknown natural gas consumption for the "sample" can be determined by using the formula derived from the reactor's thermal balance equation

$$B = \frac{P_{III}[t_p - t_{II}] + q_{nII} + q_{ЭИД} - (\Delta C_Z + \Delta C_f)c_{III}t_{III}] + F_{OC} \cdot q_{OC}}{Q_H^P + \alpha v_0^0 c_{\theta} t_{\theta} - (D+z)[c_{O_2} t_{O_2} + CO \cdot q_{CO} + H_2 q_{H_2} + Zn^I \cdot q_{Zn}]}$$

Lets identify:

$$c_{III}(t_p - t_{II}) + q_{nII} + q_{ЭИД} - (\Delta C_Z + \Delta C_f)c_{III}t_{III} = a,$$

$$Q_H^P + \alpha v_0^0 \cdot c_{\theta} t_{\theta} - (D+z)[c_{O_2} t_{O_2} + CO \cdot q_{CO} + H_2 q_{H_2} + Zn^I \cdot q_{Zn}] = \epsilon,$$

then 
$$B = \frac{P_{III} \cdot a + F_{OC} \cdot q_{OC}}{\epsilon}, \quad (12)$$

The empirical expression for the reactor's hot surface, [7]:

$$F_{OC} = 12,5 \cdot H \sqrt{F_{np}} + 15 \cdot F_{np}, \quad (13)$$

Transforming equation [1]:

$$\frac{(D+z)\beta_{np}}{3600} = c, \quad F_{np} = \frac{B \cdot c}{W_{np}}, \quad (14)$$

Solving equations (12), (13), and (14) simultaneously, we derive the equation for fuel consumption:

$$(\epsilon - 15 \cdot c \cdot q_{OC} \cdot W_{np}^{-1})B - (12,5 \cdot c^{0,5} \cdot q_{OC} W_{np}^{-0,5})H \cdot B^{0,5} - aP_{III} = 0 \quad (15)$$

By varying values of  $H_j$  in (15), we find a series of values for  $B_i$ . By substituting  $B$  in (14), we determine  $F_{npi}$ . Properly derived value of fuel consumption must satisfy the condition –

$$(H_i \cdot F_{npi}) = V^{CH\Phi}, \quad (V^{CH\Phi})_{обп} = \frac{(P_{III})_{обп}}{(P_V)_{модель}}, \quad (16)$$

We now compare the derived value of  $B_i$  with the previously set value of "B". If  $B_i \neq B$ , we repeat the calculation to derive this equality.

Table 1 shows the application of pilot installation test data results to the production sample by using affine modeling method. A "rich" waste slag from lead-smelting operation was used in the experiments.

The table data refer to a reactor with lined cyclonic section and direct natural gas combustion (without a combustion chamber).

Main similarity criteria found during testing:

1.  $H/h_0 = 3,27$ ;  $D_{об}/d_{бл} = 1,6$ .
2.  $W_C/W_{np} = 17,55$ ;  $W_C = 550 \text{ m/s}$ ;  $I_C/G_{\theta} = 0,1277$ .
3.  $\frac{P_V' \cdot q_{нол} \cdot V^{CH\Phi}}{B(D+z)c_{O_2}t_{O_2}} = 0,4243$ ,  $\frac{P_V'' \cdot q_{нол} \cdot V^{CH\Phi}}{B(D+z)c_{O_2}t_{O_2}} = 0,666$ ,

where  $P_V' = 6050 \text{ kg/m}^3 \cdot \text{hr}$  for  $E = 85\%$ ;  $P_V'' = 9500 \text{ kg/m}^3 \cdot \text{hr}$   $E = 65\%$  for extracting zinc from the melt.

$$4. \quad \frac{q_{OC} \cdot F_{OC}}{B(D+z)c_{O_2}t_{O_2}} = 0,76, \quad q_{OC} = 140 \text{ kW/m}^2$$

$$5. \quad \tau_{nep} \cdot g / W_C = 0,3656.$$

$$6. \quad t_{III} = 900^0 C, \quad t_p = 1350^0 C, \quad t_{OI} = 1450^0 C.$$

Table 1

The calculation results

Table 1		The calculation results			
1	Reactor productivity in terms of slag		5,0	12.0	25.0
2	Natural gas consumption, nm <sup>3</sup> /hr	E=65%	560	1062	1800
		E=85%	851	1600	2680
3	Reactor specific fuel consumption, nm <sup>3</sup> /tZn	E=65%	112	89	72
		E=85%	170	133	107
4	Reactor hot face, m <sup>2</sup>		23	40.5	67.7

According to [9], when processing liquefied slag with E=65-75% at the Chimkent slag-sublimation plant, the specific consumption of natural gas was 200 -230 nm<sup>3</sup>/tZn.

The following conclusions can be drawn from the data in Table 1 for the proposed unit for processing zinc-bearing slag:

1. Compared to the fuming furnace at Chimkent lead plant that processed liquefied slag, the specific consumption of natural gas will be cut in half.
2. As the productivity of the unit will increase in the 5-25 ton/hr range, the specific consumption of natural gas will decrease by a factor of 1.5

### References:

- A.D. Klyutchnikov Thermotechnical optimization of fuel-burning. M.: Energy. 1974. 343 p.
- B.I. Dikhanbayev Methodology for calculated productivity evaluation of reactors for processing lead-bearing slag. Collection of scientific reports. Moscow Energy Institute. 1988. № 176, p.47-51.
- V.A. Ippolitov Improving the efficiency of melting granulated materials in a fluidized bed process. Dissertation of Candidate of Tech. Sciences. M.: 1982.
- B.I. Dikhanbayev, A.B. Dikhanbayev Experimental studies of mixing times in KCP type reactor. Publications of Southern Kazakh State University, 1999. p. 140-142.
- A.D. Klyutchnikov, V.A. Ippolitov On the method of calculating heat exchange under conditions of highly forced blow-through across the molten Publ. of Moscow Energy Institute. 1979, issue 394, p. 63-67.
- M.E. Aerov, O.M. Todes Basic hydraulic and thermal parameters of apparatus with stationary and fluidized bed of granular materials. Л.: Химия. 1968.
- B.I. Dikhanbayev Development of intensive energy-conservation measures in lead-smelting slag fuming systems. Dissertation of Candidate of Tech. Sciences M.: 1991.
- B.I. Dikhanbayev, A.B. Dikhanbayev Calculation of fluidized bed melting parameters for lead-bearing slag fuming operations. Publications of Southern Kazakh State University. 1999. Vol. 2, p. 134-136.

# ECONOMICAL ASPECTS OF DILUTED HF SOLUTIONS ON THE ANTIREFLECTIONS PROPERTIES OF THE FLOAT GLASS SURFACES

*Jan Wasylak Prof.*

*Joanna Zontek-Wilkowska, MSc., UST-AGH*

University of Science and Technology, Faculty of Materials Sciences and Ceramics,  
Department of Glass and Amorphous Coatings Technology, Cracow, Poland

---

## Abstract

This work focuses on the development of a simple and low cost alternative to deposited antireflective coatings (ARC) through the use of a diluted HF wet chemical etching technique to form AR layers of silicon dioxide. Soda-lime-silica, low-iron glasses were used as the glass substrates. The float glass was etched for a variety of time intervals and with four different concentrations of HF solutions (0,5M, 1M, 5M, 10M). The optical properties were determined by UV-VIS spectroscopy. The microstructures were examined by SEM microscopy with EDAX analysis. The surface roughness after the wet chemical-etching was determined using an optical profilometer.

---

**Keywords:** ARC-coating, wet chemical etching technique, reflection losses, polished

## Introduction:

Coatings and thin nano-layers have been applied on glass in order to obtain various properties, which render the glass more attractive, such as anti-reflection (AR), anti-static, defogging, anti-abrasion, self-cleaning (SC), solar control and electrical conductivity [1,3].

Reflection of float-glass can be reduced and as well the transmission can be increased by using antireflective coatings (AR). In general there are two different anti-reflective coating technologies. Interference-type multilayer systems produced by sol-gel method [1] and sputtering techniques [2] and single layer nanoporous silica-based systems manufactured by dip-coating techniques [3], and also by printing techniques [4].

AR-coatings have many applications, such as spectacles, cameras, binoculars, lasers, solar cells, planar displays and others optical and optoelectronic devices. AR-technology can be used for windows in residential and commercial buildings in order to enhance the view and the energy performance of the windows. Composites of different inorganic matrixes with inorganic layers have interesting combinations of optical, electrical, thermal, magnetic, and mechanical properties as well as enhanced chemical resistance and flame-retardancy. Nano and sub micrometer particles as well known as nano and submicrometer structured materials represent one of the most rapidly expanding fields in science [5]. Recently, chemical etching process becomes attractive as an alternative of a dielectric AR layer material because of its good transparency, low refractive index and ability to form texture coating via etch processes [12-20].

In this paper the properties of AR thin films obtained by wet-etching process have been reported. Due to the phenomena of chemical etching process for a variety of time intervals and with four different concentrations of HF solutions (0,5M, 1M, 5M, 10M) was proceed.

## Experimental Part

Float SLS glass plates (4 mm thick), of dimension 50x50 mm<sup>2</sup>, were used as coating substrates. The glass samples were cleaned in the ethanol solution and deionised water for 10 minutes independently to remove all contaminate and degreased.

After cleaning process, all samples were etched for a variety of time intervals (10s, 20s, 90s, 310s) and with four different concentrations of HF solutions (0,5M, 1M, 5M, 10M), then samples were heat treated at 640<sup>0</sup>C per 15 min.

The morphology of the AR coating was studied by scanning electron microscopy (Nora Nano-SEM). Transmittance and reflectance of following samples of thin films were measured on UV-VIS spectrometer Jasco V 300 in the spectral range between 300 and 1100 nm.

## Results

The antireflection properties of thin layers are dependent on the concentrations of HF solutions for wet-chemical etching system, etching time and also thermal conditions of the heat treatment, respectively.

## Optical Properties

All prepared thin films have got high transmittance level. The sample which was etched into the 1M HF solution per 90s is characterized by the highest transmittance level and the lowest reflectance level. Increasing of concentration HF into water solution could cause the micro cracks which could indicate bad impact into the optical properties of the glass surface. The lowest (89.9 %) transmittance was observed in case glass samples etched into 10M HF solution via 310s, on the other hand the transmittance of this sample was high enough to be used as an AR layer. The transmittance and reflectance spectra of the thin films are shown in the Fig.1 –Fig 2

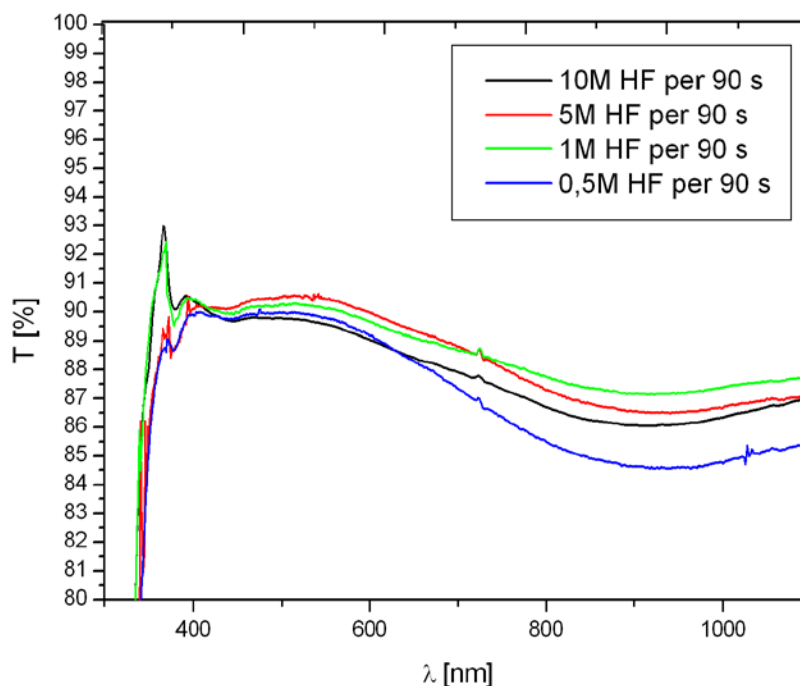

Figure 1 Transmittance spectra for 90 s etching time

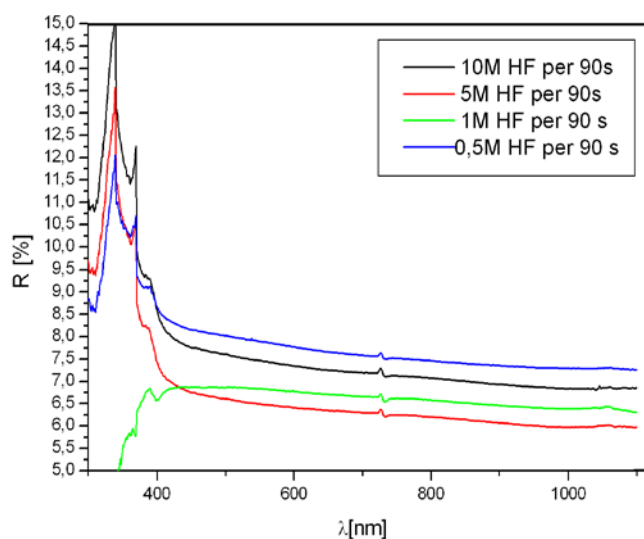

Figure 2 Reflectance spectra for 90 s etching time

### Microstructure And Surface Profile

Scanning electron microscopy is a convenient method for studying the microstructure of thin films. The microstructure of etching glass samples are shown at photos 1- 3 presented below. All layers are characterized by hierarchical structured. The EDAX analysis confirmed that the silica concentrations on the glass surface increased above 30,67 at. % for sample etched per 90s into 1M HF solution, compared to the parent-uncoated glass. In the table 1, has been shown the results of elements concentration changes for samples etched via 90 s in different acid solutions.

Table 1 The average elements concentration changes into the glass surface etched by different concentrations of HF acid solutions

Element	0,5M HF	1,0M HF	5,0M HF	10,0MHF
O	59,24	53,72	53,33	53,02
Na	9,09	9,04	9,07	9,06
Mg	2,29	2,50	2,55	2,57
Al	0,57	0,58	0,52	0,51
Si	25,87	30,67	30,07	30,53
Ca	2,97	3,49	3,46	3,74

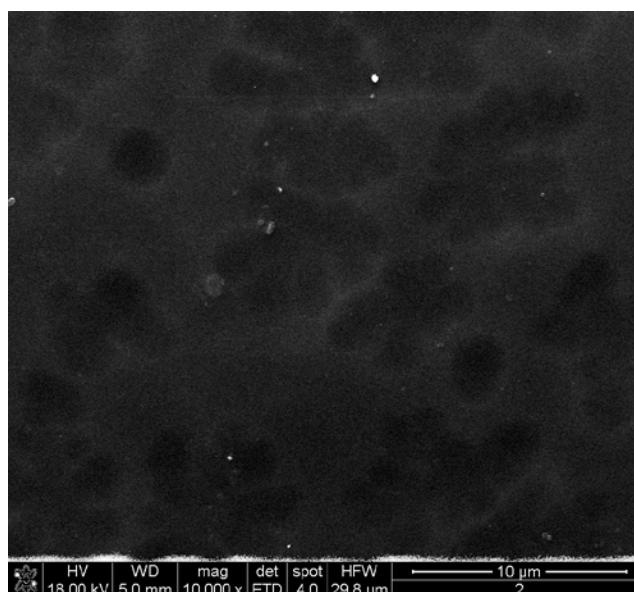

Photo 1 Microstructure of glass surface etched into 10M HF solution for 90 s

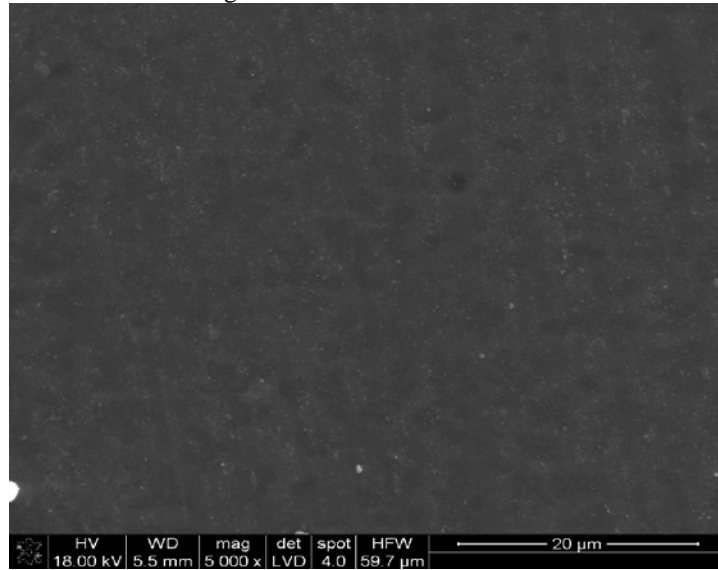

Photo 2 Microstructure of glass surface etched into 5M HF solution for 90 s

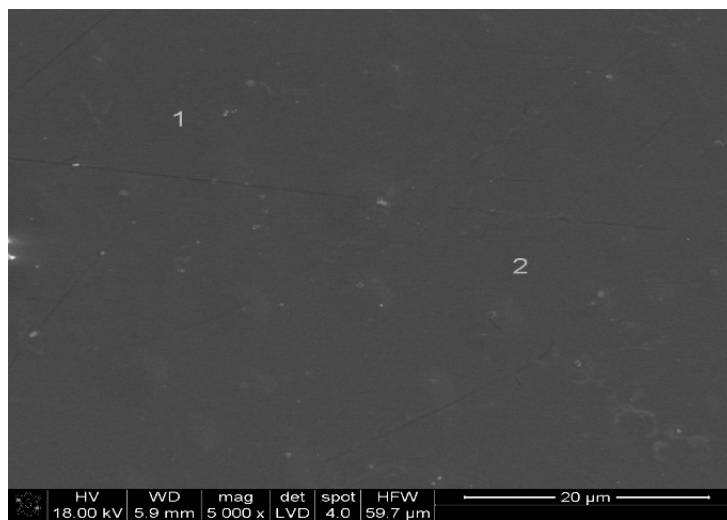

Photo 3 Microstructure of glass surface etched into 1M HF solution for 90 s

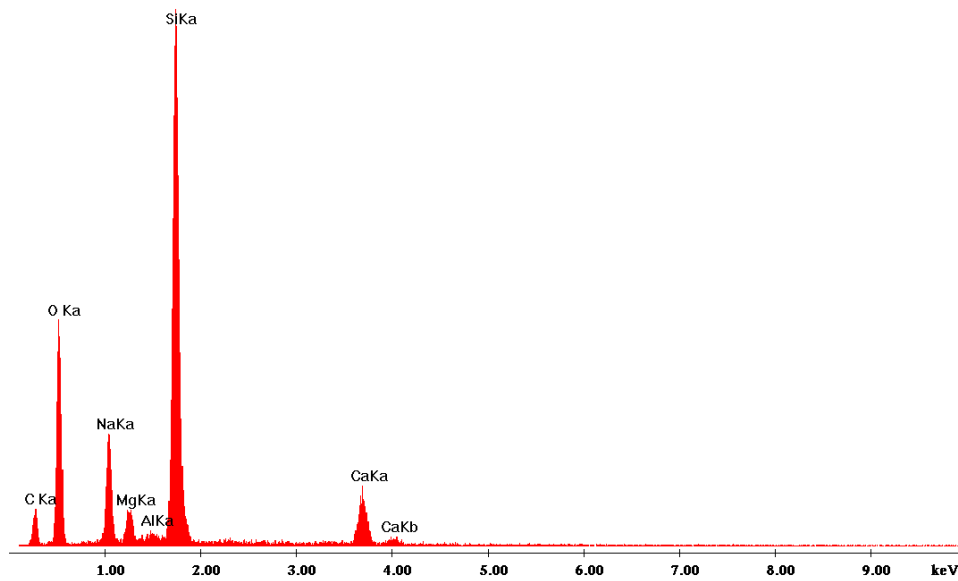

Figure 3 EDAX analysis in point 1

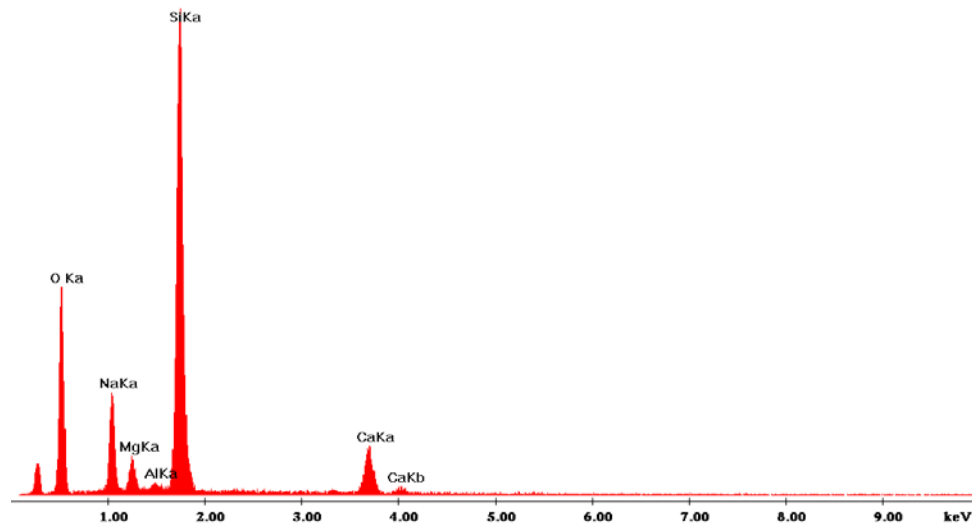

Figure 4 EDAX analysis in point 2

Moreover, there was examined the surface roughness, using optical profilometer WYKO NT930. The results show that there is a noticeable, significant increase of the surface roughness, using stronger acid solutions. The highest value of roughness  $0,3 \mu\text{m}$  had been observed for the glass sample etched into 10M HF solutions per 90s. The rest results oscillated into the same value  $0,17-0,19\mu\text{m}$ .

### Conclusion:

We have reported the influence of etching process into on the optical properties and microstructure of antireflection thin films. A simple two step procedure has been established and permitted to form the thin films with suitable parameters for ARC-coatings.

1. It was observed that the etching processes conducted into 1M HF gives the best results of transmittance above 94 % and the lowest value of reflectance spectra.
2. It has been seen the noticeable increase of the surface roughness, for the sample etched into stronger acid solutions. The highest value of roughness  $0,3 \mu\text{m}$  had been observed for the glass sample etched into 10M HF solutions per 90s. The rest results oscillated into the same value  $0,17-0,19\mu\text{m}$ .
3. The concentration of silica into the glass surface increase in all cases, but highest value, despite of the optical parameters losses got the sample etched into 10M HF solutions per 90s.

### References:

- D. Chen, Anti-reflection (AR) coatings made by sol-gel processes: A review, *Solar Energy Materials and Solar Cells*, 68, (2000), 313-336
- H. K. Pulker, *Coatings on glass*, (1999), 2ed, Elsevier, Amsterdam
- [D. Chen, Anti-reflection (AR) coatings made by sol-gel processes: A review, *Solar Energy Materials and Solar Cells*, 68, (2000), 313-336, P. Nostell, A. Roos, B. Karlsson, Antireflection of glazings for solar energy applications, *Solar Energy Materials and Solar Cells*, 54, (1998), 223-233.
- M. Fukawa, T. Ikeda, T. Yoneda and K. Sato, Antireflective coatings with single layer with refractive index of 1.3, *Proceedings of the 3rd International Conference on Coatings on Glass (ICCG)*, (2000), 257-264



- Yoshitaka Nakano, Takeshi Morikawa, Takeshi Ohwaki and Yasunori Taga, *Appl. Phys. Lett.* 88 (2006) 172103.
- Y. Kanamori, M. Sasaki, K. Hane, *Opt. Lett.* 24 (1999) 1422
- K. Hadob'as, S. Kirsch, A. Carl, M. Acet, E.F. Wassermann, *Nanotechnology* 11(2000) 161.
- S. Wang, X.Z. Yu, H.T. Fan, *Appl. Phys. Lett.* 91 (2007) 0611058 3 pages.
- G.-R. Lin, Y.-C. Chang, E.-S. Liu, H.-C. Kuo, H.-S. Lin, *Appl. Phys. Lett.* 90 (2007) 1819238, p.3
- C.H. Sun, W.-L. Min, N.C. Linn, P. Jiang, B. Jiang, *Appl. Phys. Lett.* 91 (2007) 2311058,p.3
- C.H. Sun, P. Jiang, B. Jiang, *Appl. Phys. Lett.* 92 (2008) 0611128 3 pages.
- J. Zhu, Z. Yu, G.F. Burkhard, C.-M. Hsu, S.T. Connor, Y. Xu, Q. Wang, M. McGehee, S. Fan, Y. Cui, *Nano Lett.* 9 (2009) 279.
- E. Garnett, P. Yang, *Nano Lett.* 10 (2010) 1082.
- Y. Lu, A. Lal, *Nano Lett.* 10 (2010) 4651.
- M.-L. Kuo, D.J. Poxson, Y.S. Kim, F.W. Mont, J.K. Kim, E.F. Schubert, S.-Y. Lin, *Opt. Lett.* 33 (2008) 2527.
- P. Yu, C.-H. Chang, C.-H. Chiu, C.-S. Yang, J.-C. Yu, H.-C. Kuo, S.-H. Hsu, Y.-C. Chang, *Adv. Mater.* 21 (2009) 1618.
- S.Y. Chou, P.R. Krauss, J. Renstrom, *Appl. Phys. Lett.* 67 (1995) 31148 3 pages.
- V. Boerner, S. Abbott, B. Blasi, A. Gombert, W. Hobfeld, *SID. Symp. Digest* 34 (2003)68.
- C.J. Ting, M.-C. Huang, H.-Y. Tsai, C.-P. Chou, C.-C. Fu, *Nanotechnology* 19 (2008) 2053018 5 page.
- Y. Kanamori, E. Roy, Y. Chen, *Microelectron. Eng.* 78–79 (2005) 287.
- Mitsuhiro Kawakami, A.B. Hartanto, Y. Nakata, T. Okada, *Jpn. J. Appl. Phys.* 42(2003) L 33.
- K.-S. Kim, H.W. Kim, *Phys. B* 328 (2003) 368.
- R. Liu, A.A. Vertegel, E.W. Bohannon, T.A. Sorenson, J.A. Switzer, *Chem. Mater.* 13(2001) 508.
- L.E. Greene, M. Law, D.H. Tan, M. Montano, J. Goldberger, G. Somorjai, P. Yang, *Nano Lett.*5 (2005) 1231.
- Y. Tak, K. Yong, *J. Phys. Chem. B* 109 (2005) 19263.
- Z. Chen, L. Gao, *J. Cryst. Growth* 293 (2006) 522.
- M. Riaz, A. Fulati, G. Amin, N.H. Alvi, O. Nur, M. Willander, *J. Appl. Phys.* 106 (2009) 034309.
- Y.J. Lee, D.S. Ruby, D.W. Peters, B.B. McKenzie, J.W.P. Hsu, *Nano Lett.* 8 (2008) 1501.
- T.H. Ghong, Y.D. Kim, E. Ahn, E. Yoon, S.J. An, G.-C. Yi, *Appl. Surf. Sci.* 255 (2008) 746.

# MITIGATION OF METALLIC ION CONCENTRATIONS IN THE ENVIRONMENT USING MICROORGANISMS

**Vasile-Sorin Manoiu, PhD (Material Science), Scientific Researcher**  
Biological Sciences National Research-Development Institute, Bucharest, Romania  
**Valentina-Mariana Manoiu, MD (Biol), PhD (Natural Sciences), Senior Lecturer**

University of Bucharest, Romania, Faculty of Geography

**Manuel Drugulescu, Scientific Researcher**

SC Compreserv SRL, Bucharest, Romania

**Ovidiu Popa, PhD (Biochemistry), Prof.**

University of Agronomic Sciences and Veterinary Medicine of Bucharest,  
Faculty of Biotechnologies, Romania

---

## Abstract

Microorganisms, particularly bacteria, have the ability to bind and precipitate metals from different solutions, intracellularly or on the cell surface. An important application field of nanobiotechnologies is the mitigation of certain metals' toxic effects by using microorganisms such as bacteria or yeasts. The product obtained through the microorganism activity is several times less toxic than the initial one. *Bacillus subtilis* is a bacterium that has the capacity of metal bioaccumulation. These bacteria can bioaccumulate Ag and Fe metallic ions from Ag and Fe ions solutions very rapidly. Microorganisms display large silver and iron based nanostructured deposits on the surface and in the immediate vicinity. Biosynthesis of silver and iron nanoparticles with the help of microorganisms is an ecological, viable, low cost, relatively easy and high-efficient method that allows the use of certain inexpensive biotechnologies for the metal absorption from the environment. This method can be tested for the metallic ions mitigation in the environment.

---

**Keywords:** Microorganisms, metallic ions, nanoparticles, bacillus subtilis, Ag (silver) and Fe (iron)

## 1. Introduction

Microorganisms, particularly bacteria, have the ability to bind and precipitate metals from different solutions, intracellularly or on the cell surface (Cohen 2006; Xiangqian Li et al. 2011). This particularity is determined by the small size of the bacterial cell and the great surface/volume ratio which ensure a prolonged contact with the metallic ions of the watery solutions (Warren and Haack 2001; Xiangqian Li et al. 2011).

The existence of two types of bioaccumulation was established:

- metals found in solutions have electropositive charges and they bind to the electronegative structures of the microorganisms' cell surface; these structures correspond to the extracellular polymers of the cell wall (Garbisu and Alkorta 2003);
- metal accumulation in the cells' cytoplasm.

These processes can be detected in both living cells and inactivated ones.

An important application field of nanobiotechnologies is the diminishment of certain metals' toxic effects by using microorganisms such as bacteria or yeasts, which can reduce metallic ions and form metal compounds (Kowshik et al. 2003; Williams et al. 2006).

As their forms and sizes are controllable, the nanoparticles that are obtained through biological methods have special features depending on the microorganism that is being used (Prathna et al. 2010; Sadowski Z. 2010). The product of either the action of microorganisms or even that of parts of certain superior plants (roots, leaves) is several times less toxic than the initial one.

A series of genera of unicellular microorganisms (bacteria, yeasts or algae) accumulate nanoparticles intracellularly or deposit them extracellularly:

- bacteria have been used in order to obtain nanoparticles of Au, Ag, Hg, As, CdS, ZnS, FeS, etc (Williams et al. 2006; Xiangqian Li et al. 2011);
- yeasts have been studied in order to obtain PbS and CdS nanoparticles (Xiangqian Li et al. 2011);
- algae have been used in order to obtain Au nanoparticles (Sadowski 2010).

## 2. Methodology

### 2.1. The interaction between *Bacillus subtilis* and metals

*Bacillus subtilis* is a bacterium that has the capacity of metal bioaccumulation. This bacterium, which naturally lives in the presence of metallic ions, is therefore quite intriguing within the study of metal resistance. Scientific literature provides the results of several research studies regarding the adaptation of the *Bacillus subtilis* bacterium to metals (Bruins et al. 2000; Williams et al. 2006).

Bacterial cells have stick-like shape and are large sized; the polysugars found on the surface of the cell form a capsule; as the spore percentage is determined by the oxygen quantity in the environment, the spore generation process represents an identification criterion. This bacterium is Gram-positive.

In liquid media it does not accentuate turbidity. On solid media it forms large, inconsistent, irregular, opaque, unpigmented colonies. The optimum temperature for multiplication is of 28°C. These bacteria use glucose, fructose, sucrose and maltose as carbon sources. They hydrolyze starch and slowly liquefy gelatine. The reactions of indole, urease and H<sub>2</sub>S are negative. The haemolytic activity is weak. They produce catalasis.

### 2.2. Experimental methods for biomass obtainment

The obtainment of bacterial biomass was achieved through cell cultivation in a minimal culture medium in a discontinuous system, with the following formula:

meat extract	0,30 g %
fish extract	0,30 g %
peptone	2,00 g %
NaCl	0,52 g %
glucose	0,20 g %
the pH of the culture medium	7,2

1 ml of the ATCC 2589 and ATCC 6633 stems of the *Bacillus subtilis* was inoculated into 200 ml of culture medium divided into 250 ml phials. The samples were then incubated at a temperature of 30°C for 48 hours, being stirred every 2 hours for 15 minutes.

### 2.3. Performed analyses

Samples were taken every 8 hours in order to:

- a) assess bacterial purity and fungal sterility;
- b) assess the biochemical features of bacterial cells;
- c) determine the multiplication dynamics of bacterial cells by tracing growth rate curves for the two *Bacillus subtilis* stems.

### 2.4. The assessment of bacterial purity and fungal sterility

The purity of the culture was assessed by inoculating 5 test tubes of the culture medium which contained sodium thioglycolate - 3 samples for each stem.

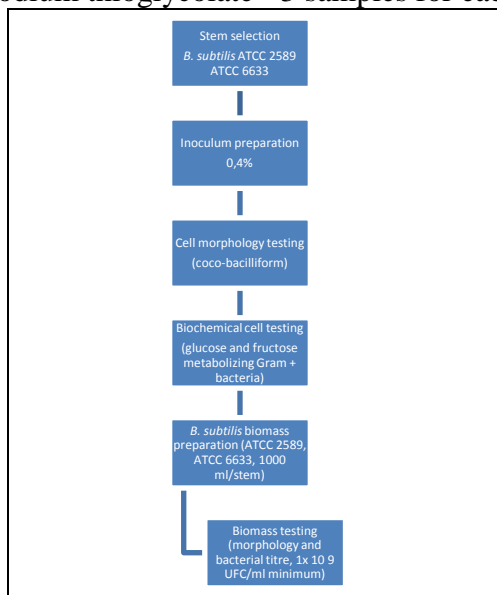

Figure 1. Stages of bacterial biomass obtainment

The samples were incubated at a temperature of 37°C for 7 days.

The fungal sterility was assessed by inoculating 3 samples (for each stem) in a Sabouraud liquid medium.

The samples were incubated at a temperature of 28°C for 14 days.

Results: The samples were bacteriologically pure and fungally sterile.

Conclusion: The cultures were obtained by respecting the appropriate sterility and cultivation requirements.

## 2.5. The biomass preparation for Ag and Fe ions bioabsorption

The bacterial biomass used in the bioabsorption process was centrifuged at 6 000 rpm for 30 minutes. Each stem was cultivated in a volume of 1000 ml. The deposit was washed once in a AgNO<sub>3</sub> solution and once in a FeSO<sub>4</sub> 0,001 M solution, by centrifuging at 6 000 rpm. Once the supernatant was removed, the ATCC 2589 și ATCC 663 cell deposit was placed in AgNO<sub>3</sub> 0,05 M, 0,01 M, 0,001 M solutions, at a 1:6 ratio. Equal *B. subtilis* ATCC 2589 and ATCC 6633 biomass quantities were placed in FeSO<sub>4</sub> 0,05M, 0,01 M, 0,001 M solutions, at a 1:6 ratio. The resulting samples were incubated for 72 hours, being stirred at 200 rpm every 2 hours; the incubation temperature was of 30 °C.

### Conclusion:

1. The bacterial biomass which was used in the bioabsorption process does not contain traces of the culture medium, the purification of the bacterial cells having been obtained by centrifugation at 6 000 rpm.

2. The dilutions of the salts (FeSO<sub>4</sub> and AgNO<sub>3</sub>) used in the process, were of 0,001 M, 0,01M and 0,05 M.

3. The biomass was incubated for 72 hours, being stirred at 200 rpm; the incubation temperature was of 30 °C.

4. The dilution at which the best bioabsorption results were obtained - through transmission electron microscopy - was of 0,001 M.

5. The analyzed samples were pure; bacterial cells were not in sporulated form; the microscopic fields showed a high dark cell density due to the metal deposition on their surfaces that followed the action of neutral enzymes - scientific literature confirms the fact

that *Bacillus subtilis* stems can synthesize neutral proteases that are exported by the bacterial cells; these neutral proteases can transport metallic ions and simple molecules and deposit them outside bacterial cells (Williams et al. 2006; Xiangqian Li et al. 2011).

6. The stages of the bioabsorption and nanostructuring of the metals in solutions of varying dilutions are presented in Figure 2.

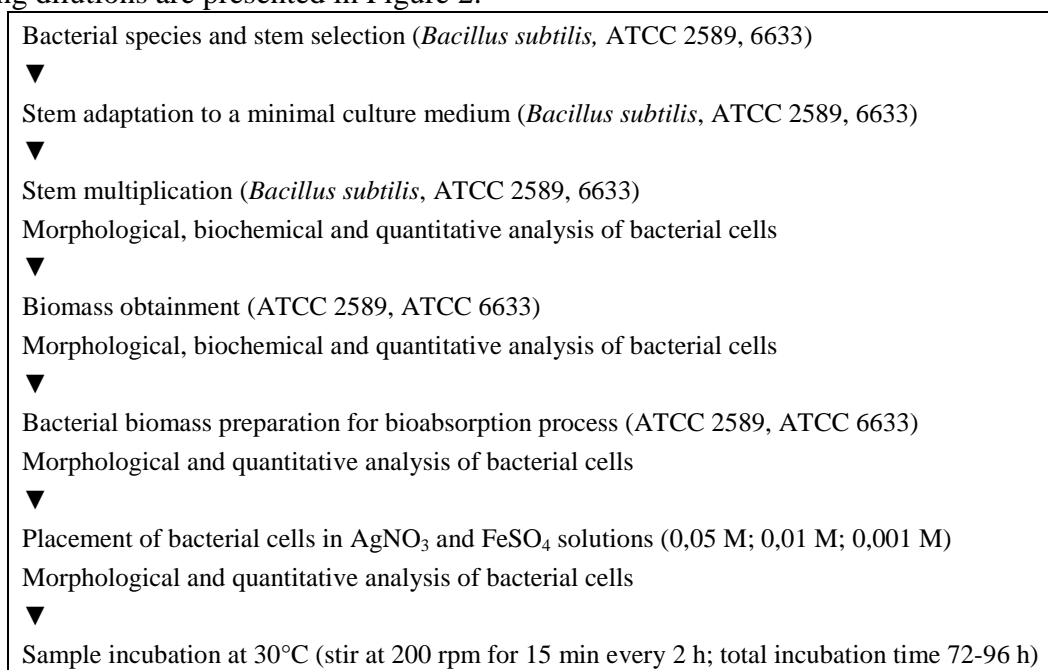

Figure 2. Scheme of the biotechnological process of bioabsorption (*B. subtilis*; Ag, Fe)

## 2.6. Determination of metal concentrations

The determination of metal concentrations was carried out by the use of mass adsorption spectrophotometry, employing lamps of different wavelengths, depending on the characteristics of each metal.

The metal bioabsorption experiments performed on the *Bacillus* species showed that metal ions were very rapidly taken out of the solution (10 minutes). After these first 10 minutes, no other adsorption level augmentations were recorded. The comparison between the biosorbants' adsorption capacities was carried out in identical pH, temperature and stirring speed conditions for each metal.

The maximum adsorption capacity for Ag was of 38%. The reason why Ag's adsorption is lower than that of other metals' is that *Bacillus sp.* is a Gram-positive bacterium and the biosorbants of its cell wall show a high affinity for anions and a lower one for cations.

## 2.7. Transmission electron microscopy for Ag samples

The transmission electron microscopy was used in order to examine the way adsorption and nanostructured metal formation occur, the way cell division processes occur for the microorganisms which are being used, the transformations the microorganisms go through after having interacted with the culture medium (solutions of high metal ion concentrations).

It was therefore possible to determine the microorganisms' sizes, shapes and internal structures, the disposition and placement of nanostructured particle deposits, as well as their shapes and sizes.

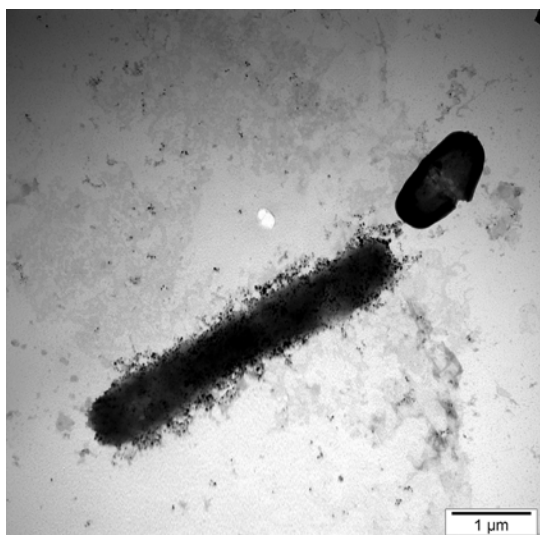

Figure 3. TEM image. Silver-based nanostructured particle deposits found on and inside the microorganism.

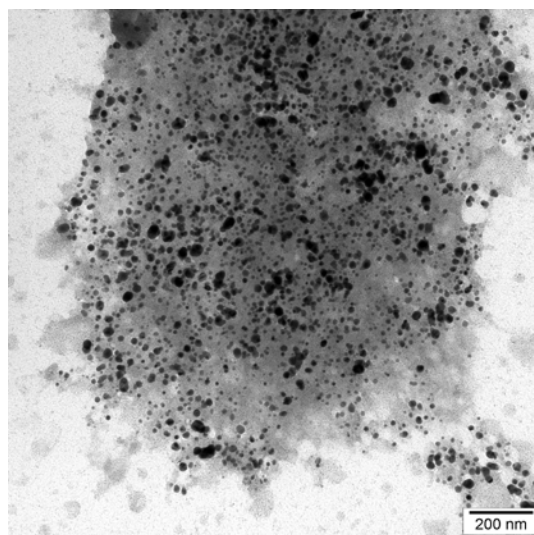

Figure 4. TEM image. A disintegrating microorganism can be seen, as well as a colony with multiple silver-based nanostructured particle deposits.

The resulting particle deposits vary in shape and size. The predominant shape is the spherical one; ellipsoidal, tetrahedral and octagonal deposits were also found. Dimensionally, the nanostructured particle deposits ranged from 4 to 48 nm.

## 2.8. Electronic microscope scanning of the Ag samples

The scanning electron microscope (SEM) was used in order to obtain information on the morphology and topography of the nanostructured metal deposits.

The microscope is equipped with an EDX detector that helped obtain compositional, qualitative and quantitative analyses, as well as element distribution patterns for each of the analyzed samples.

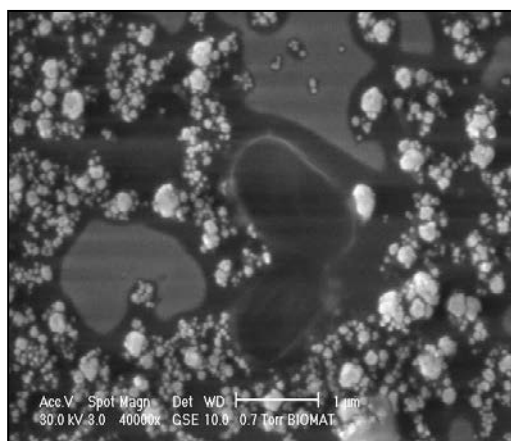

Figure 5. Electronic microscope scanning image. Silver-based nanostructured metal deposits can be seen as light-coloured (bright) points and structures.

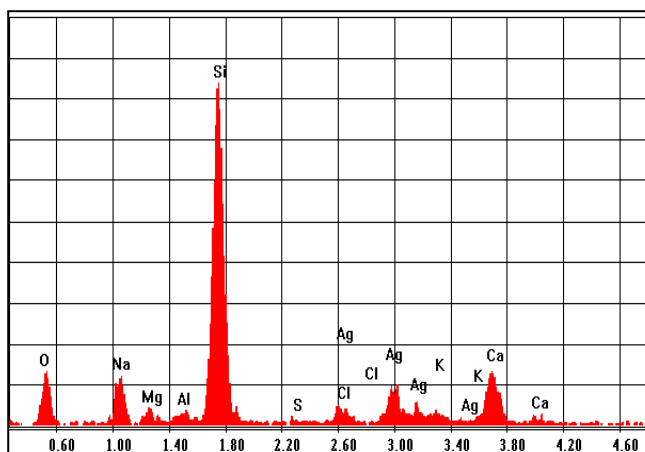

Figure 6. EDX analysis spectrum on a silver-based metal particle. The spots for silicon and other elements correspond to the lines given by the composition of the glass slide

The procedures targeted the highlighting of nanostructured metal deposits through compositional, qualitative and quantitative assessments in the medium, on the microorganisms and on the metal particles of the deposits or those of the microorganisms.

## 2.9. Transmission electron microscopy for Fe samples

The use of transmission electron microscopy (TEM) revealed that the biosynthesis processes of nanostructured metal particle deposits which use microorganisms in a high iron ion concentration culture medium, differ from those of silver ions. Therefore, particle deposits are less distinguishable than in the case of silver, as the process of deposition is quantitatively lower. The identified deposits comprise less regularly-shaped particles than in the case of silver. Dimensionally, particle sizes range from 5 to 50 nm, thus being similar to silver ones. Although larger particles were also identified, it is quite difficult to say whether the particles were autonomous or agglomerations of smaller particles.

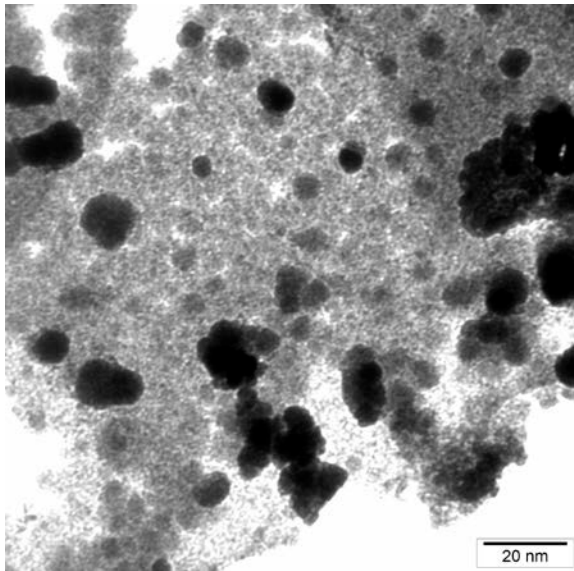

Figure 7. TEM image. Nanostructured particles obtained through biosynthesis, by using a high iron concentration culture medium can be seen.

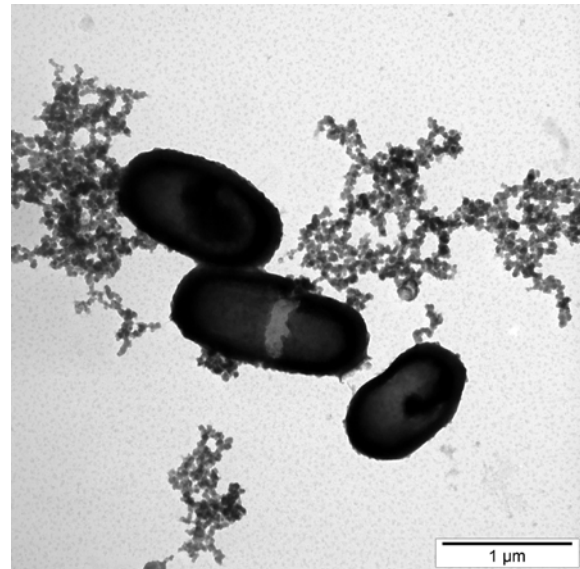

Figure 8. TEM image. Nanostructured particles and microorganisms in various stages can be seen.

## 2.10. Electronic microscope scanning for Fe samples

Information with regard to the morphology and topography of iron-based nanostructured metal deposits was obtained by using the SEM. The EDX detector provided compositional, qualitative and quantitative analyses, as well as element distribution patterns for the analyzed sample.

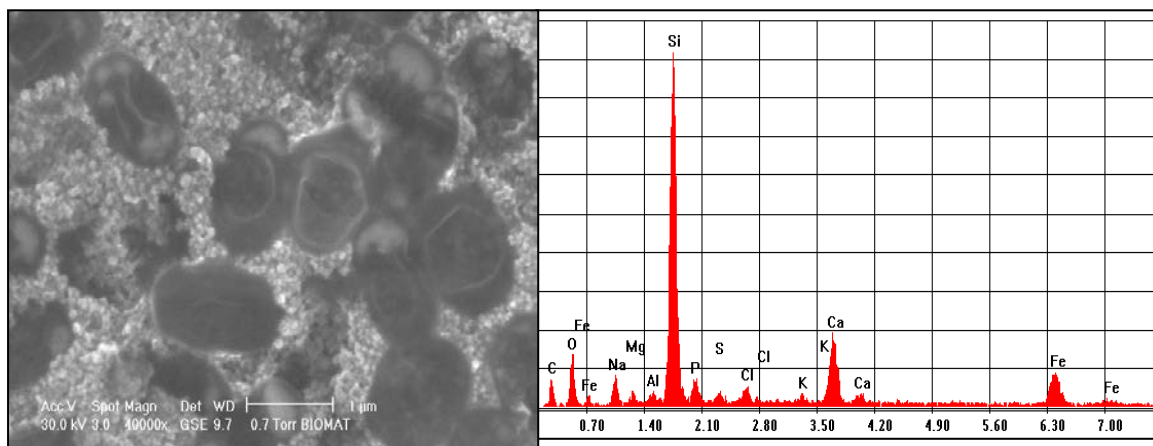

Figure 9. Additionally enlarged SEM image. Microorganism agglomerations and particle deposits due to biosynthesis can be seen.

Figure 10. EDX spectrum analysis inside a microorganism on an iron-based metal particle. The spots for silicon and other elements correspond to the

lines given by the composition of the glass slide.

The procedures that were carried out targeted the highlighting of nanostructured metal deposits through compositional, qualitative and quantitative assessments in the medium, on the microorganisms and on the metal particles of the deposits or those of the microorganisms.

### **3. Discussions and conclusion**

#### **3.1. Ag nanoparticles obtainment**

From the computations and analysis performed by using TEM and SEM microscopy and EDX methods, the following conclusions could be drawn:

- Silver-based nanostructured particle deposits were highlighted;
- As the particles are separated, the identified deposits do not comprise agglomerations;
- The identified microorganisms display large silver-based nanostructured particle deposits on the surface and in the immediate vicinity;
- Silver-based nanostructured particle deposits show a relatively uniform dimensional distribution, ranging from 4 to 50 nm;
- The TEM diffraction of the silver-based nanostructured particles highlighted their crystallinity;
- With the help of SEM, the metallic nature of nanostructured particle deposits could be confirmed;
- With the help of EDX, compositional, qualitative and quantitative analyses, as well as element distribution patterns for the analyzed samples could be carried out;
- Through EDX analysis, silver concentrations of 8,09 % mass percentage on a medium particle and of 4,32 for a particle inside a microorganism were found (by reducing the background intensity), 1,84 and 1,01 respectively for their atomic percentages.

#### **3.2. Fe nanoparticles obtainment**

From the computations and analysis performed by using TEM and SEM microscopy and EDX methods, the following conclusions could be drawn:

- Iron-based nanostructured particle deposits were highlighted;
- The identified deposits comprise agglomerations and separated particles;
- The identified microorganisms display iron-based nanostructured particle deposits on the surface and in the immediate vicinity;
- The iron-based nanostructured particle deposits range dimensionally from 5 to 50 nm;
- By using SEM, the metallic nature of nanostructured particle deposits could be confirmed;
- With the help of EDX, compositional, qualitative and quantitative analyses, as well as element distribution patterns for the analyzed samples could be carried out;
- Through EDX analysis, iron concentrations of 2,64 % mass percentage on a medium particle and of 1,22 for a particle inside a microorganism were found (by reducing the background intensity), 0,76 and 0,36 respectively for their atomic percentages.

#### **3.3. General conclusions**

- The biosynthesis of iron and silver nanostructured particles by using microorganisms is a viable, relatively easy and high-efficient method that allows the use of certain inexpensive biotechnologies for the metal absorption from the environment;
- Particles are generally spherically-shaped, with sizes ranging from 4 nm to 50 nm and feature a protein coat;
- The method can be tested for the metallic ions mitigation in the environment.



**References:**

- Bruins MR, Kapil S, and Oehme FW. Microbial Resistance to Metals in the Environment. *Ecotoxicology and Environmental Safety*. 45(3):198-207.2000. Available from: <http://dx.doi.org/10.1006/eesa.1999.1860>
- Cohen RRH. Use of microbes for cost reduction of metal removal from metals and mining industry waste streams. *Journal of Cleaner Production*. 14(12-13): 1146-1157. 2006. Available from: <http://dx.doi.org/10.1016/j.jclepro.2004.10.009>
- Garbisu C, and Alkorta I. Basic concepts on heavy metal soil bioremediation. *The European Journal of Mineral Processing and Environmental Protection*. 3(1). 1303-0868. 58-66. 2003.
- Kowshik M, Ashtaputre S, Kharrazi S, Vogel W, Urban J, Kulkarni SK, and Paknikar KM. Extracellular synthesis of silver nanoparticles by a silver-tolerant yeast strain MKY3. *Nanotechnology* 14:95. 2003. Available from: [doi:10.1088/0957-4484/14/1/321](https://doi.org/10.1088/0957-4484/14/1/321)
- Prathna TC, Lazar M, Chandrasekaran N, Raichur AM, and Mukherjee A. Biomimetic Synthesis of Nanoparticles: Science, Technology & Applicability. *Biomimetics Learning from Nature*. Amitava Mukherjee (Ed.). ISBN: 978-953-307-025-4. InTech. 2010. Available from: <http://www.intechopen.com/books/biomimetics-learning-from-nature/biomimetic-synthesis-of-nanoparticles-science-technology-amp-applicability>
- Sadowski Z. Biosynthesis and Application of Silver and Gold Nanoparticles. *Silver Nanoparticles*. David Pozo Perez (Ed.). ISBN: 978-953-307-028-5. InTech. 2010. Available from: <http://www.intechopen.com/books/silver-nanoparticles/biosynthesis-and-application-of-silver-and-goldnanoparticles>
- Warren LA, and Haack EA. Biogeochemical controls on metal behaviour in freshwater environments. *Earth-Science Reviews*. 54 (4): 261-320. 2001. Available from: [http://dx.doi.org/10.1016/S0012-8252\(01\)00032-0](http://dx.doi.org/10.1016/S0012-8252(01)00032-0),
- Williams DN, Ehrman SH, and Pulliam Holoman T.R. Evaluation of the microbial growth response to inorganic nanoparticles. *Journal of Nanobiotechnology* 4:3. 2006. doi:10.1186/1477-3155-4-3
- Xiangqian Li, Huizhong Xu, Zhe-Sheng Chen, and Guofang Chen. Biosynthesis of Nanoparticles by Microorganisms and Their Applications. *Journal of Nanomaterials*. 2011. doi:10.1155/2011/270974. Available from:

# INFLUENCE OF AIR-DECK LENGTH ON FRAGMENTATION IN QUARRY BLASTING

*Suttithev Rommayawes, MS*

Rajamangala University of Technology Lanna (RMUTL), Thailand

*Chewchan Leelasukseree, PhD*

*Pirat Jaroopattanapong, PhD*

Department of Mining Engineering, Faculty of Engineering,  
Chiang Mai University (CMU), Thailand

---

## Abstract

An air gap in the explosive column known as an air deck has been applied in open-pit blasting as a means to reduce explosive charge, vibration, fly rock, and improve fragmentation and controlled blasting in some situations. Determining the appropriate air-deck length and optimum fragmentation is still in question despite many applications and studies. In this research, a total of 30 air-deck blasts with air-deck lengths between 15-65% of the charge length were tested while also considering two other important parameters: maximum joint spacing and blasting direction. Average fragmentation size was obtained from image processing analysis and used as an indicator of blasting performance. Results indicate that the average fragmentation size increases relative to the higher percent air-deck length and maximum joint spacing. In addition, an unfavorable blasting direction also increases average fragmentation size. The relationship between average fragmentation size and an air-deck length is displayed on a graph for simplicity of uses. The small to medium opening feed size of a normal primary crusher may vary between 93cm (37 inches) to 112cm (44 inches) so an air-deck length between 20-30% of the charge length can be used with a high possibility that the average fragmentation size will be less than 100cm. With favorable parameters, an air-deck length of up to 40% is worth testing in the quarry mines; however, other uncontrollable parameters exist and may also affect blast fragmentation.

---

**Keywords:** Air-deck, blasting, fragmentation, quarry

## 1. Introduction

Since Melnikov and Marchenko (1971) proposed the air-deck theory of how one or more air gaps used in the explosive column called air deck can improve fragmentation, the technique has been studied and increasingly applied in presplit and also production blasting in open-pit mines. Despite numerous practical applications and research into air-deck blasting, improvements in fragmentation do not always occur and questions remain regarding the optimum length of the air gap to be used. Two main factors affect blast results, which can be generally separated into controllable and uncontrollable factors. Examples of controllable factors are the types of explosive used and geometry of the blast pattern, while uncontrollable factors relate primarily to geological structure. This paper discusses the results of experimental blasts conducted in two quarry mines to evaluate the relationship between the length of the air deck (as a percentage of charge length in the blast hole) and the required fragmentation size. The maximum spacing of discontinuity and the angle between the direction of the strata and the blast break were also considered.

## 2. Theory of air-decking

The theory was first proposed by Melnikov and Marchenko (1971), and Melnikov et al. (1979), who postulated that when shock waves reflect from the boundary between the stemming bed and an air gap, a secondary shock wave is generated that extends the network of fractures prior to gas pressurisation. The degree of fracture is increased by the second shock wave and the duration of the shock wave action on the rock surrounding the hole is also prolonged. Consequently, the crack network within the rock mass is increased when using air-deck blasting techniques.

Moxon et al. (1993) indicated that if the air deck is placed in the middle of the explosive column, the pressure front will collide at the centre of the air deck. This interaction should develop a reinforced stress field and result in a more radial crack pattern than if an air deck was kept on the top of the charge.

## 3. Blasting experimentation

The experiments were conducted in two quarry mines. One is located in northern Thailand and known as Lampang quarry mine, while the other is located in central Thailand and is known as Supan quarry mine. Limestone productions from the Lampang mine are mostly used for flue gas desulfurization (FGD) processing to capture sulfur dioxide gas released from coal-fired power plants. Productions from the Supan mine are used only for cement production.

Blast performance, particularly the fragmentation size of the rock, was observed and analyzed, using Spilt Desktop (demo version) image processing software. In order to isolate and evaluate the effect of air-deck length, other blast design parameters, such as hole diameter, bench height, burden and spacing were kept similar. The number of holes varied between 20-30 per blast. However, the two mines have more than one production area and also have different blasting directions. For this reason, the direction of the strata (bedding) and the blast break were observed in the fields and represented as a controllable parameter. In addition, geotechnical information was collected in all 30 experimental blasts to determine different rock masses and rock mass quality at the different locations. An air deck (A) was placed on top of the charge as shown in Figure 1. Detailed geological investigations are presented in Section 4, while Tables 1 and 2 shows details of all blasting patterns and air deck lengths, which varied from approximately 15-65% of the charge length in the charge column of both mines.

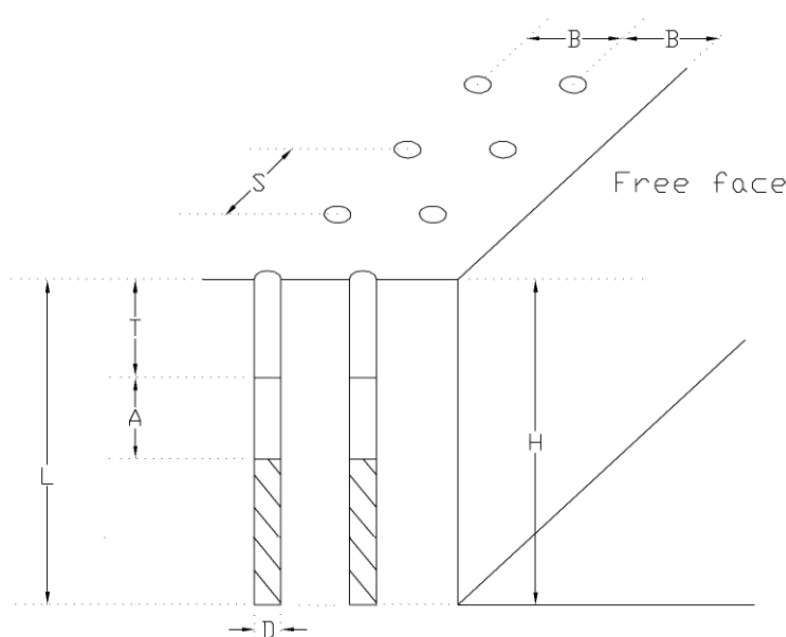

Figure 1 Air deck position (A) placed between stemming (T) and explosive charge

Table 1 Blast pattern and air deck length in Lampang mine

Blast No.	Burden (m.)	Spacing (m.)	Stemming (m.)	Air deck (m.)	Total hole length (m.)	Charge length (m.)	% of air deck compared to charge length
1	3.00	3.00	2.00	0.80	8.50	5.70	14.04
2	3.00	3.00	2.00	0.80	8.50	5.70	14.04
3	3.00	3.00	2.00	0.80	8.50	5.70	14.04
4	3.00	3.00	2.00	1.20	8.50	5.30	22.66
5	3.00	3.00	2.00	1.20	8.50	5.30	22.66
6	3.00	3.00	2.00	1.20	8.50	5.30	22.66
7	3.00	3.00	2.00	1.50	8.50	5.00	30.00
8	3.00	3.00	2.00	1.50	8.50	5.00	30.00
9	3.00	3.00	2.00	1.50	8.50	5.00	30.00
10	3.00	3.00	2.00	1.80	8.50	4.70	38.30
11	3.00	3.00	2.00	1.80	8.50	4.70	38.30
12	3.00	3.00	2.00	1.80	8.50	4.70	38.30
13	3.00	3.00	2.00	2.00	8.50	4.50	44.44
14	3.00	3.00	2.00	2.00	8.50	4.50	44.44
15	3.00	3.00	2.00	2.00	8.50	4.50	44.44

Table 2 Blast pattern and air-deck length in Supan mine

Blast No.	Burden (m.)	Spacing (m.)	Stemming (m.)	Air deck (m.)	Total hole Length (m.)	Charge length (m.)	% of air deck compared to charge length
1	2.60	3.50	2.00	2.00	8.50	4.50	44.44
2	2.60	3.50	2.00	2.00	8.50	4.50	44.44
3	2.60	3.50	2.00	2.00	8.50	4.50	44.44
4	2.60	3.50	2.40	1.50	11.50	7.60	19.74
5	2.60	3.50	2.40	1.50	11.50	7.60	19.74
6	2.60	3.50	2.40	1.50	11.50	7.60	19.74
7	2.20	2.50	2.00	1.40	7.50	4.10	34.15
8	2.20	2.50	2.00	1.40	7.50	4.10	34.15
9	2.20	2.50	2.00	1.40	7.50	4.10	34.15
10	2.20	2.50	2.00	2.20	7.50	3.30	66.67
11	2.20	2.50	2.00	2.20	7.50	3.30	66.67
12	2.20	2.50	2.00	2.20	7.50	3.30	66.67
13	2.50	2.50	2.40	3.20	11.50	5.90	54.24
14	2.50	2.50	2.40	3.20	11.50	5.90	54.24
15	2.50	2.50	2.40	3.20	11.50	5.90	54.24

#### 4. Geotechnical investigations

Preliminary geotechnical investigations for both mines were conducted by considering several rock mass parameters such as uniaxial compressive strength, rock quality designation index (RQD), spacing of discontinuity, and conditions of discontinuity, which comprises discontinuity length (persistence), separation (aperture), roughness, infilling (gouge) and weathering. The conditions of these parameters are shown in Table 3 and 4 for the Lampang and Supan mine, respectively. A total of 30 blast experiments were conducted: 15 blasts in both the Lampang and Supan mines. Bieniawski's rock mass rating (RMR) was determined to compare rock mass quality in both quarry mines. The RMR at both locations varies from 64-81, indicating there is not much difference in RMR between the two mines. However, the joint spacing parameter is significantly different so the maximum joint spacing was collected and used as an uncontrolled parameter.

Table 3 Bieniawski's RMR at Lampang mine

Blast No.	Value (rating)									RMR <sup>2</sup>
	UCS (MPa)	RQD (%)	Joint spacing (m)	Ground water	Joint conditions					
					Discontinuity Length (m.)	Aperture (mm.)	Roughness <sup>1</sup>	Infilling	Weathering	
1	8.00	100	0.5	dry	7	0.3	6-8	none	slightly	75
2	5.31	100	1.35	dry	6	0.2	8-10	none	moderately	80
3	9.27	100	1.125	dry	12	0.1	2-4	none	slightly	81
4	4.82	97	1.2	dry	17	0.3	6-8	none	slightly	79
5	7.17	100	1.65	dry	6	0.2	8-10	none	unweathered	78
6	5.38	100	0.75	dry	12	0.5	2-4	none	slightly	78
7	8.32	90	1.05	dry	22	0.4	4-6	none	moderately	76
8	9.73	100	1.625	dry	15	0.1	2-4	none	slightly	81
9	6.34	100	0.9	damp	13	0.2	2-4	none	unweathered	74
10	4.16	100	1.1	damp	11	0.1	2-4	none	unweathered	74
11	6.30	100	0.575	damp	12	0.2	4-6	none	slightly	69
12	7.57	100	1.05	damp	15	0.2	2-4	none	unweathered	79
13	6.04	93	1.25	damp	25	0.3	4-6	none	slightly	73
14	6.89	100	0.5	dry	20	0.3	2-4	none	slightly	72
15	9.13	100	0.825	dry	23	0.2	4-6	none	slightly	81

<sup>1</sup> Joint Roughness Coefficient (JRC) using Barton and Choubey's Table<sup>2</sup> Bieniawski's RMR

Table 4 Bieniawski's RMR at Supan mine

Blast No.	Value (rating)									RMR <sup>2</sup>
	UCS (MPa)	RQD (%)	Joint spacing (m)	Ground water	Joint conditions					
					Discontinuity Length (m.)	Aperture (mm.)	Roughness <sup>1</sup>	Infilling	Weathering	
1	5.78	100	0.65	dry	20	0.3	4-6	none	unweathered	77
2	13.17	100	0.73	dry	20	0.2	4-6	none	unweathered	80
3	8.49	100	0.74	dry	21	0.5	4-6	none	unweathered	77
4	4.35	100	0.93	dry	20	0.3	4-6	none	unweathered	77
5	4.27	100	1.13	dry	20	0.4	4-6	none	unweathered	77
6	6.47	97	1.13	dry	20	0.4	4-6	none	unweathered	77
7	7.77	100	0.78	damp	20	0.2	4-6	none	unweathered	72
8	9.38	100	0.60	damp	20	0.7	4-6	none	slightly	71
9	10.01	100	0.70	dry	20	0.5	4-6	none	slightly	79
10	10.41	97	0.80	damp	20	0.6	4-6	none	moderately	72
11	4.55	98	0.63	damp	20	0.3	4-6	none	moderately	69
12	7.46	100	0.43	damp	20	0.5	4-6	none	moderately	64
13	7.06	100	0.65	dry	20	0.4	4-6	none	moderately	74
14	7.76	100	0.70	damp	20	0.3	4-6	none	moderately	69
15	6.10	100	0.68	dry	20	0.7	4-6	none	moderately	74

<sup>1</sup> Joint Roughness Coefficient (JRC) using Barton and Choubey's Table<sup>2</sup> Bieniawski's RMR

As mentioned above, the inclination of the strata was recorded in every blast to determine the angle between the direction of the strata and blast direction in order to ascertain whether or not the blast directions are in favorable, acceptable or unfavorable directions based on the information presented in Figure 2 (Jimeno, et al., 1995)

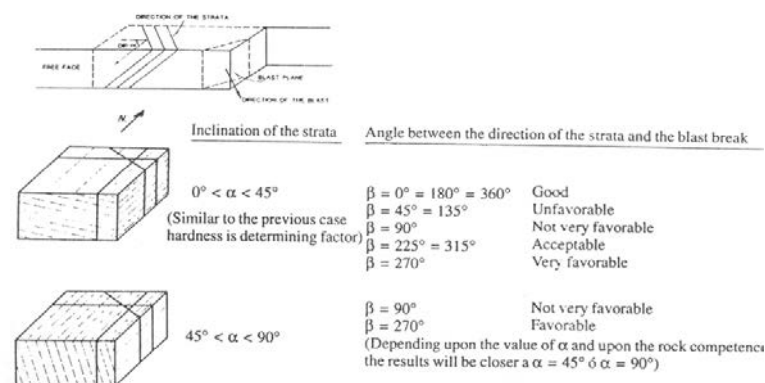

Figure 2 Fragmentation results in different directions compared to strata (Jimeno, et al., 1995)

### 5. Assessment of fragmentation

Photographs of the muck pile were taken, including 4 10-inch balls, which were used for scale references, as exemplified in Figure 3. Each of the 4 balls was placed separately on the rock muck pile. The example photograph in Figure 3 is further divided into 4 small photographs, with each one containing one ball for reference. The small photographs were then processed with Split Desktop (demo version) to provide the results of cumulative size distribution as shown in Figure 4. The results from the 4 small photographs were averaged to obtain the cumulative size distribution of the whole muck pile. The 80% passing size is used to indicate blast performance in this study.



Figure 3 An example photo with the reference balls

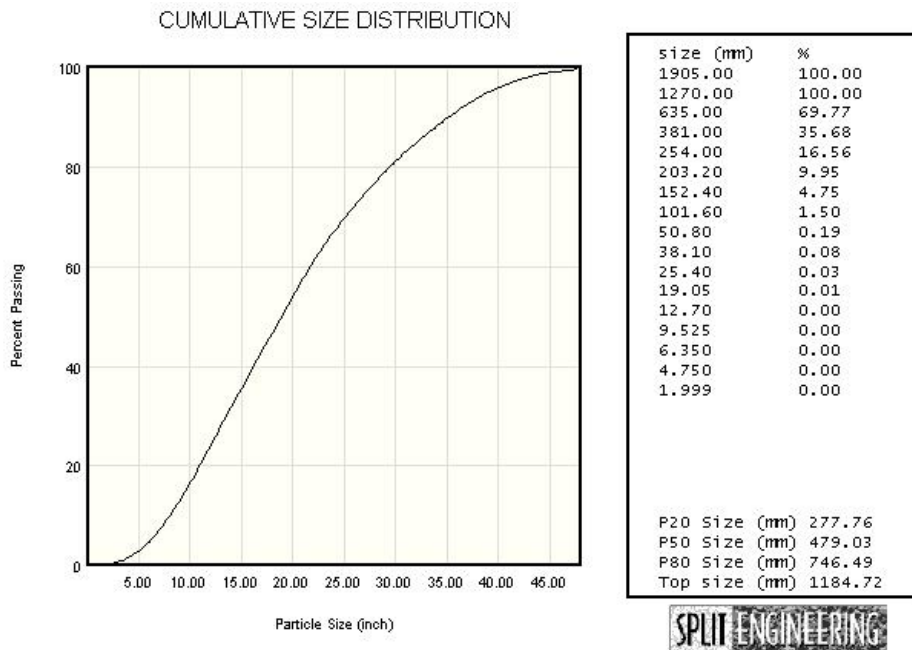

Figure 4 Cumulative size distribution obtained from the Split-Desktop program

### 6. Impact of air-deck length and designed parameters on fragmentation

The influence of air-deck length on fragmentation was evaluated in term of average (80%) passing size while considering two other parameters: maximum joint spacing and blasting direction results compared to the dip strata. Table 5 summarizes the results from both mines.

The average passing size and percent air-deck length of all blasts in Table 5 were plotted in one graph, as shown in Figure 5. When maximum joint spacing data were applied, the data points can be roughly categorized into 2 range bands: less than 200cm and between 200-300cm, as presented in Figure 6 and 7. In addition, blast directions are also provided and shown along with the data points.

Table 5 Details of air-deck blast results at Lampang and Supan mines

Blast No.	Lampang mine				Supan mine			
	80% passing size (cm)	Max. Joint Spacing (cm)	Blast Direction	% of Air deck length	80% passing size (cm)	Max. Joint Spacing (cm)	Blast Direction	% of Air deck length
1	56.17	80	favorable	14.04	51.25	125	acceptable	44.44
2	87.21	250	acceptable	14.04	48.40	140	acceptable	44.44
3	72.57	210	acceptable	14.04	48.56	138	acceptable	44.44
4	73.85	230	favorable	22.66	43.18	180	acceptable	19.74
5	81.00	300	acceptable	22.66	43.10	220	acceptable	19.74
6	59.16	140	acceptable	22.66	35.51	220	acceptable	19.74
7	110.09	200	unfavorable	30.00	44.61	150	acceptable	34.15
8	77.10	300	acceptable	30.00	47.44	110	acceptable	34.15
9	66.00	150	acceptable	30.00	48.42	130	acceptable	34.15
10	90.14	200	unfavorable	38.30	63.02	150	unfavorable	66.67
11	103.77	100	unfavorable	38.30	63.18	120	unfavorable	66.67
12	72.54	200	favorable	38.30	62.26	80	acceptable	66.67
13	92.39	240	unfavorable	44.44	52.44	120	unfavorable	54.24
14	91.48	90	unfavorable	44.44	52.45	130	unfavorable	54.24
15	76.64	150	acceptable	44.44	59.96	130	unfavorable	54.24

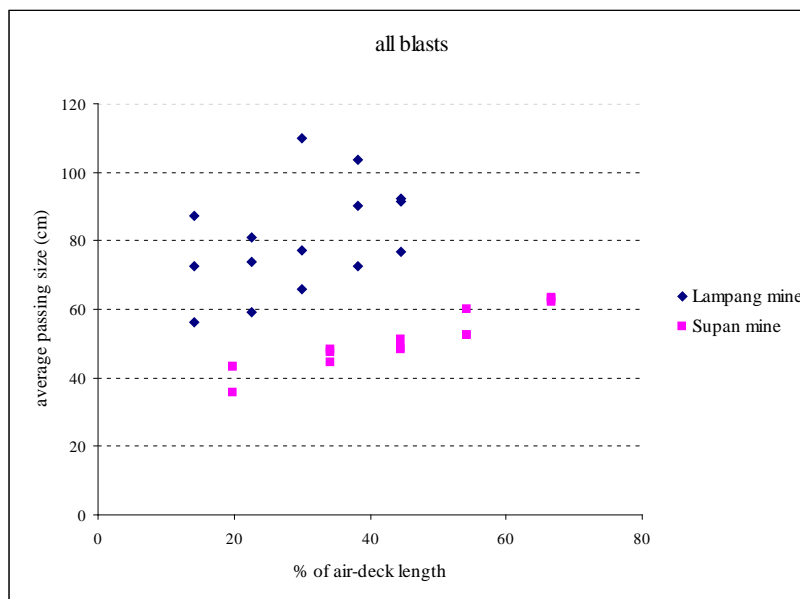

Figure 5 Fragmentation from all air-deck blasts

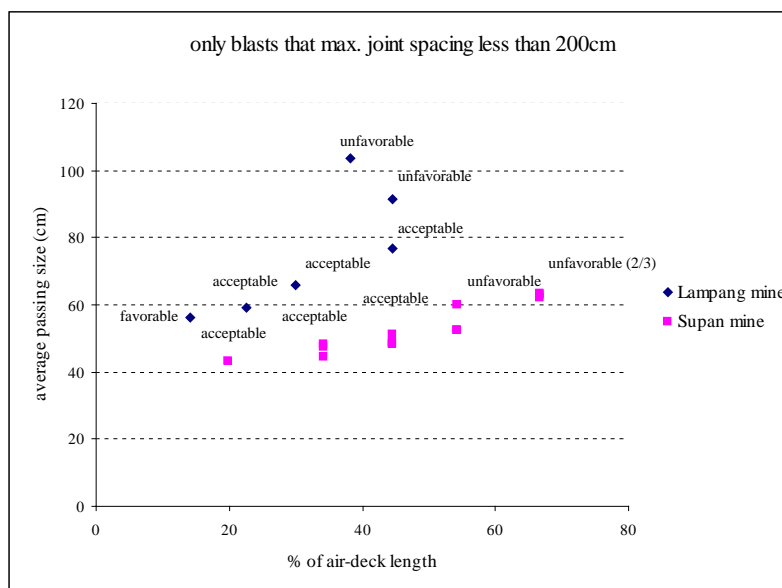

Figure 6 Blast with maximum joint spacing less than 200cm

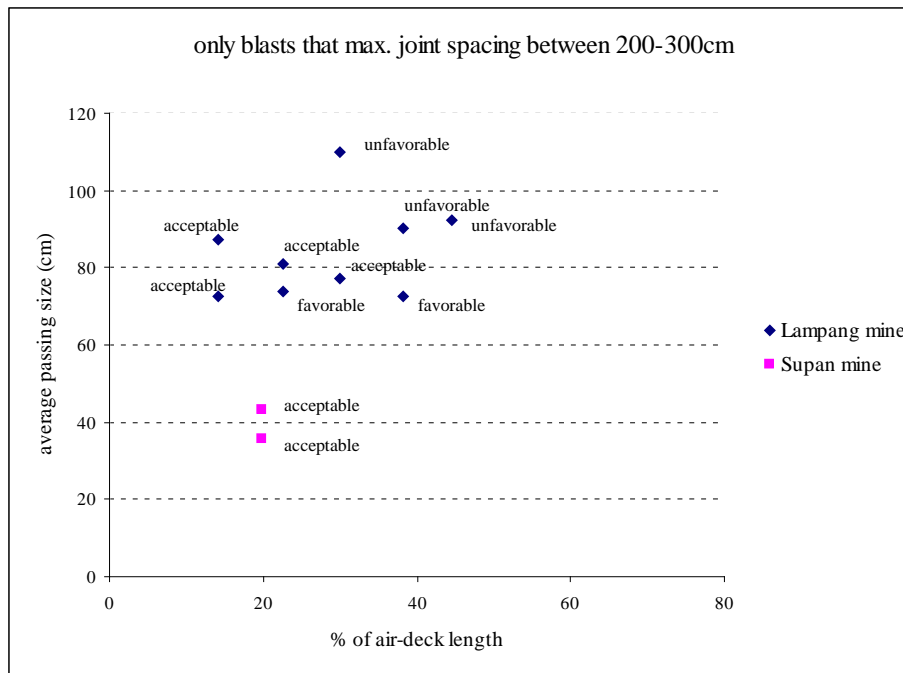

Figure 7 Blast with maximum joint spacing between 200-300cm

**7. Analysis and conclusion**

The average passing size tends to steadily increase with a higher percentage air-deck length. This is clearly seen in the blasts at both mines, where maximum joint spacing is less than 200cm and in mostly acceptable blast direction (Figure 6). With the unfavorable blast directions, the average passing size suddenly increases. Blasts that have a maximum joint spacing of between 200-300cm give average passing size clustering at bigger sizes compared to the maximum joint spacing of less than 200cm (Figure 7). It is evident that when joint spacing is longer (rock is more massive), the average 80% passing size is expected to be bigger.

Figure 8 shows that trend lines can be drawn to provide the possible area (between trend line 1 and 2,) of average passing size with maximum joint spacing of less than 200cm. The enclosed line (line 3) in Figure 8 is drawn to indicate the possible area (between trend line 2 and 3) of the average passing size with maximum joint spacing of between 200-300cm and also the possible area of the average passing size with maximum joint spacing of more than 300cm. In addition, blasts with unfavorable directions also result in a bigger average passing size compared to acceptable directions. One hypothesis line (a line with arrowheads) is also drawn to indicate the possible area where blasts with unfavorable directions appear, which is mostly in upper areas. The complete graph in Figure 8 summarizes the relationship between the average passing size and percent air-deck length along with the other two parameters.



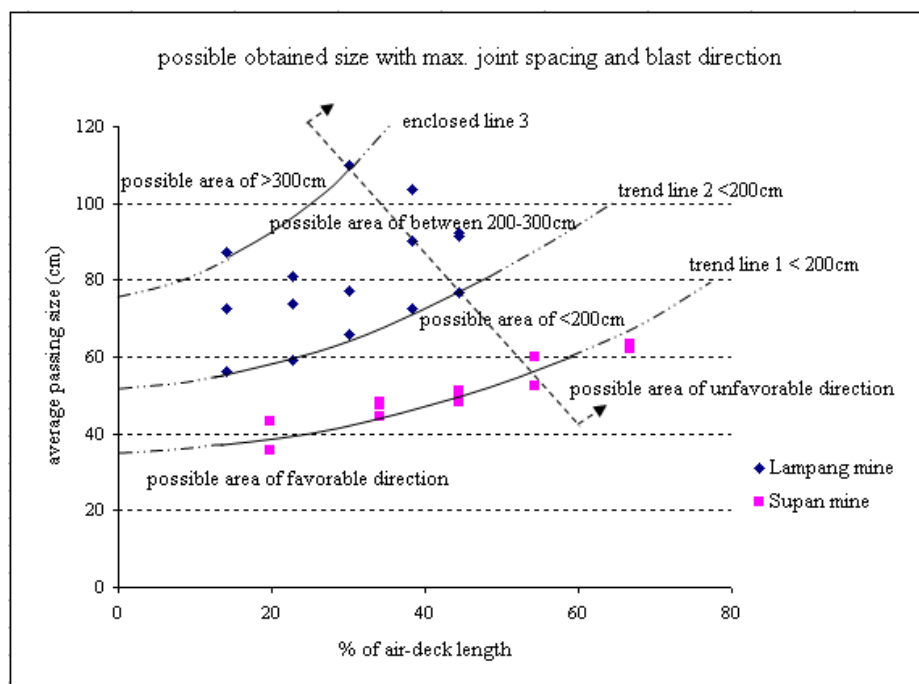

Figure 8 Areas of possible obtained an average 80% passing size from various air-deck lengths

By categorizing the data points and considering the parameters, possible areas of the average passing size can be obtained for different air-deck lengths as shown in Figure 8. For example, using an air-deck length of 20% can result in an average passing size of between 40-60cm if the maximum joint spacing is less than 200cm, or between 60-90cm if maximum joint spacing is more than 200cm. With the maximum joint spacing more than 300cm, an average passing size more than 90cm can be obtained. Unfavorable blasting directions will increase the average passing size clearly seen in an air-deck length of 40%, while the increasing of an average passing size obtained from using an air-deck length more than 50% is unclear. The small to medium opening size may vary from between 93cm (37 inches) to 112cm (44 inches), so an air-deck length of between 20-30% gives a high possibility that the average passing size will be less than 100cm. With favorable parameters, an air-deck size of up to 40% is worth testing in the quarry mines. However, other uncontrollable parameters still exist and may affect the blast fragmentation

### References:

- Bieniawski, Z.T. Engineering classification of jointed rock masses. *Transaction of the South African Institution of Civil Engineers* 15(12), 335-344, 1973.
- Jimeno, C.L. Emilio Lopez Jimeno and Francisco Javier Ayala Carcedo. *Drilling and blasting of rocks. Geomining Technology Institute of Spain.* 165, 1995.
- Melnikov, N.V., Marchenko, L.N. *Effective methods of application of explosive energy in mining and construction. Twelfth Symposium on Dynamic Rock Mechanics. AIME, New York, 1971.*
- Melnikov, N.V., Marchenko, L.N., Seinov, N.P., Zharikov, I.F. *A method of enhanced rock blasting by blastin. Fiziko-Tekhnicheskie Problemy Razrabotki Poleznykh Iskopaemykh (Journal of Mining Science)* 6, 32-42, 1979.
- Moxon, N.T., Mead, D., Richardson, M. *Air decked blasting techniques: some collaborative experiments. Transactions Institution of Mining and Metallurgy Section A: Mining Industry* 102, A25-A30, 1993.

# TRACE METALS CHARACTERISATION IN ENVIRONMENTAL MEDIA: A CASE STUDY OF CEMENT PRODUCTION AREA, EWEKORO, SOUTHWEST, NIGERIA

*A.O. Majolagbe, PhD Candidate*

*K.A. Yusuf, PhD*

*A.E.Duru, MSc*

Department of Chemistry, Lagos State University. Lagos, Nigeria

---

## Abstract

Environmental quality deterioration resulting from increase in the level of potentially toxic metals is becoming more pronounced, thus raising the question on safety status of environment. Characterisation and impact assessment of trace metals in the environmental media including groundwater, top soils, and tree barks in the vicinities of West African Portland Cement Company factory mill, Ewekoro, Ogun State, Nigeria was undertaken. The environmental samples were analysed for trace metals employing flame atomic absorption spectrometry (FAAS). The concentration of Cu, Cd and Fe detected in the groundwater samples ranged from 0.026-0.082, 0.0038-0.004 and 0.003-0.035 (mg/L) respectively. The decreasing order of metals observed in the top soil samples is Fe > Pb > Ni > Cr > Cu > Cd, while the pattern of trace metals concentration analysed in tree barks samples is Fe > Cu > Cr > Pb > Ni > Cd. The saturated index of the groundwater samples were saturated to undersaturated with respect to sulphates; Cd (OH)<sub>2</sub>, CdSO<sub>4</sub>, Melanterite (FeSO<sub>4</sub>·7H<sub>2</sub>O), while samples were saturated to supersaturated with respect to Otavite (CdCO<sub>3</sub>) and Siderite (FeCO<sub>3</sub>). Quality indices employed in analyzing soil data include enrichment factor (EF), contamination factor (CF) and pollution load index (PLI). The EF indicates the build up of trace metals in the environment (soil) particularly Pb. The level of metals analysed are within the threshold limit set by the WHO health-based guideline for drinking water. Significant correlation was found to exist between Cd and Ni, Cr and Fe both in the tree bark and top soil samples, suggesting common source.

---

**Keywords:** Groundwater, toxic metals, saturated index, pollution load index, ewekoro

## Introduction

The level of Industrial activities in a nation is a mark of its development. The planning of such is with objectives that include: economic benefits, creating employment, thereby reducing crime rate and poverty as well as improving general standards of living. However, these industrial activities are not without adverse consequences on the environment. Therefore, setting up an industry is often guided by standards so as to make the environment safe and sustainable. These standards include majorly, establishing an Environmental Impact Assessment (EIA) on the proposed industrial activity. Among other things, the EIA report predicts environmental consequences of a project and possibly recommends ways to mitigate against such condition. The levels of heavy metals in the environment have been on increase in the last few decades due to various anthropogenic activities, notably manufacturing and mining activities (Tahawy et al., 2006), as well as the use of synthetic products such as pesticides, paint, and batteries (USDA, 2000). The industrial processes are also responsible for the wider diffusion of these elements in the environment (Miranda, 2005). Heavy metal is a term used for a wide group of metallic elements with density equal or greater than 5g/cm<sup>3</sup>.

Such metals include cadmium, copper, chromium, lead, nickel and iron. They are trace elements when their occurrences in the environment is less than 0.02 part per million. They are generally associated with pollution and toxicity (Knight et al., 1997). Trace metals occur naturally in soils (but rarely at toxic levels), sedimentary deposits and water bodies; therefore, there are normal background concentrations of these metals. These metals also found their way (anthropogenic sources) into soils, vegetations, water bodies and sediments via airborne particulate matter in the form of dust and vehicular emission. Many researchers (Okonkwo et al., 2006, Chimuka et al., 2005) have reported elevated concentration of trace metals from roadsides, food waste, lubricating oils, sewage systems among other sources. Cement production is characterized by particulate air pollutants, which are produced during blasting of raw materials, grinding of cement, packaging or loading of finished cement. Some of the numerous components of cement includes alumina, silica, polychlorinated dioxins, furans and heavy metals such as mercury, antimony, calcium, zinc, lead, chromium arsenic and manganese, majority of which are potentially harmful elements (PHEs) to the biotic components of the environment (Gbadebo and Bankole, 2007).

Metallic elements such as Fe, Zn, Mo, Cu, Co and Cr are known to be essential elements. They play vital roles in various metabolic activities in plants and animals at trace level, however, at high concentration, they may be potentially toxic (Chimuka et al., 2005). Copper is an essential substance to life, it is a part of several enzymes including Tyrosinase which helps in formation of melanin pigment. It also helps in utilization of iron. Copper normally occurs in drinking water from copper pipes, as well as from additives designed to control algal growth, however, at high concentration, it can cause anemia, liver and kidney damage as well as stomach and intestinal irritation. Excessive intake of Cu may also cause death with symptoms such as hypertension, coma and jaundice (Riordan, 1983). People with Wilson's disease are at greater health risk from overexposure to copper. Deficiency of Cu is dangerous, characterized by microcytic anemia resulting from defective hemoglobin synthesis. Heavy metals such as Pb, Cd and Ni are toxic even at trace level and they adversely affect life under varying health conditions. For instance, cadmium, an inevitable by product of Zinc refining is acutely toxic, with chronic exposure, it affects the kidney and there are some evidence that, it is associated with an increased incidence of cancer of the prostate. Cadmium may interfere with the metallothionein's ability to regulate zinc and copper concentrations in the body system. Metallothionein is a protein that binds to excess essential metals to render them unavailable, when cadmium induced metallothionein activity; it binds to copper and zinc disrupting the homeostasis levels. Lead (Pb) is one of the most abundant, ubiquitously distributed toxic elements. Lead and its organic compound are accumulative toxins which enter the body system through inhalation of dust, fumes and vapour or by ingestion (Folinbee, 1993). Lead contamination results from mining and smelting activities, lead-containing paints, paper and pulp, gasoline, explosives, and the improper disposal of municipal sewage sludge containing lead. In animals, lead at high concentration adversely affects the reproductive, nervous, immune, cardio-vascular, and other systems. Growth and photosynthetic processes of plants are affected by Pb through inhibition of enzyme activities and alterations in membrane permeability leading to water and mineral imbalances (Mishra et al.2006). Pb is actively pathogenic to brain development in children. (Liu et al.2007). Lead, when in high concentration, substitute for calcium in the bone. Children are especially susceptible to this form of lead poison because developing skeletal systems require high levels of calcium.

The toxicity of heavy metals in aquatic environment is largely a function of water chemistry and sediment composition in the water body system. Slightly elevated metal levels in natural waters may cause morphological change in tissues, suppression of growth and development, poor swimming performance, change in enzyme activity and reproduction in aquatic organisms. Heavy metal pollution in soil has been assessed by Liu et al. (2007) using

pollution index (Pi), which was obtained as a ratio of metal concentration in contaminated soil to its concentration in natural background sample. Toxicity of heavy metals is related to their existing species; hence, speciation of these cations is increasingly attracting more attentions (Tahawy et al., 2006). The soil, plants and water in the neighborhood of the cement company are being threatened by pollution from the company. Prevention is still the best method to protect the environment from contamination of heavy metal, more so, that cleaning of contaminated soil is difficult and expensive. This study therefore, investigated the concentration levels of potentially harmful toxic metals in groundwater, tree barks and top soil in the vicinities WAPCO of cement production. It will help in establishing the safety level of the environment and a data base for further studies.

### **3.0 Materials And Methods**

#### **3.1 Study Area**

Ewekoro works, one of the mills of West African Portland Cement Company (WAPCO) where this study was carried is situated in Ewekoro town in Ogun state. Ewekoro town, a sleepy neighboring town to Papalanto, a name known for Sugar cane plantation. It lies between latitude  $6^{\circ} 53'$  North, and longitude  $3^{\circ} 14'$  East. It is bounded in the north by Abeokuta, in the east by Obafemi Owode, in the West by Yewa South and in the South by Ado-Odo-Ota. The geology of Ogun State covering Ewekoro town, comprises of sedimentary rocks which underlie approximately three quarters and the remaining one quarter covered by basement rocks (Kehinde- Phillips, 1992). The sedimentary rocks of Ogun State consist of Ewekoro formation and Abeokuta formation. The Ewekoro formation is fossiliferous and consists of economic deposits of lime stones that is presently quarried by WAPCO (Omosola *et al.*, 1981).

#### **3.2 Samples and Sampling Techniques**

A total number of fifteen (15) groundwater samples, ten (10) top soil samples (0 –15 cm) and ten (10) plant bark samples were collected. The sampling locations were carefully chosen after a pre-sampling site survey. Plastic containers for groundwater samples were thoroughly washed with detergent, rinsed with water and then with distilled water before soaking with 10% of HNO<sub>3</sub> overnight (Protano, 2005). The containers were finally rinsed with deionised water prior sample collection. Groundwater samples from shallow wells in the villages within the vicinity of Ewekoro cement works were collected into two different plastic containers; 1.5 L and 0.5 L for Physico-chemical and metal analyses respectively. The 0.5L water was spiked with 1.0 ml of concentrated HNO<sub>3</sub> (Analar) so as to preserve the samples. The soil sampling spots were cleaned of debris and composite top soils with depth between 0 cm and 15cm were collected at different selected sampling points to provide a representative coverage of the study site using soil auger and transferred into clean acid-washed polyethylene bags. This layer of soil constitutes the absorption zone of the roots of most food crops such as cassava (*Manihot esculenta*) and sugar cane (*Saccharum officinales*) grown within the Ewekoro town, the host of West African Portland Cement Company (WAPCO) mill, southwestern Nigeria. Composite controls sample for top soil were collected from Ifo and Oju -ore (about 5 km and 20 km respectively from the study area) so as to confirm the consistency in reduction of metal concentration with distance away from the study site. Composite tree bark samples were collected at a height of 3 m above the ground level (Majolagbe et al., 2011) using clean acid-washed stainless knife and further washed after each sampling with 10% HNO<sub>3</sub> to avoid cross contamination. The barks were designated P<sub>1</sub>-P<sub>6</sub>. Control for bark samples was collected from Oju -ore and placed in clean acid washed polyethylene bags. All samples were transported to the laboratory, the water samples were stored in the refrigerator at 4<sup>0</sup>C, top soils and plant barks were air dried at room temperature until analysis.

### 3.3 Sample Chemical Analyses

#### i. *Hydrochemistry*

The pH and temperature of the groundwater samples were determined in-situ. The pH was carried out with pH meter (pHep HANNA HI 98107) and temperature was estimated using thermometer. Determination of alkalinity was done titrimetrically (APHA, 1998), Total Hardness by complexometry (APHA, 1998), Total suspended solids, Dissolved solids and Total solids by gravimetry (DOE, 1972 and APHA, 1998), Chloride by Mohr's method (APHA, 1998) and Sulphate by turbidimetric method (APHA, 1998). Determination of cations: Cr, Pb, Cd, Ni, Fe, and Cu was also carried out, in line with methods of chimuka et al., (2005), employing Flame Atomic Absorption Spectrophotometer. (Buck scientific 210 VGP model).

#### ii *pH of the top soil samples* .

The pH of top soils samples was determined using sieved soil samples. 2g of each top soil samples was weighed into clean beaker; deionised water was added gradually to form a slurry solution and the mixture was allowed to stand for 30minutes with occasional stirring using a glass rod. The pH was then taken using calibrated pH meter (pHep HANNA HI 98107).

#### iii *Metal content of the soil samples.*

The top soil samples were air dried and pulverized using clean laboratory mill, then sieved through 500 um aperture. 2.0 g of pulverized soil sample was taken in a 250ml beaker and moistened with few drops of deionized water to prevent loss by spattering during digestion. The sample was digested with 10ml of concentrated HNO<sub>3</sub> on a hotplate in a fume cupboard to volume of about 3 ml. The residues obtained were further digested with a mixture of concentrated acids containing 5 ml each of concentrated HCl, HNO<sub>3</sub> and HClO<sub>4</sub> at room temperature for 10 minutes until the solution was brought to a final volume of about 5ml on a hot plate in fume cupboard. The digest was allowed to cool and filtered into a 100 ml volumetric flask using whatman No.1 filter paper. It was then made up to mark with the deionised water. The control samples were also treated with the same procedure as above.

#### iv *Metal content of the Tree bark samples*

The tree bark samples were air dried at room temperature, crushed with clean laboratory mill and then sieved through 500 um aperture to obtain fine bark particles. 2.0 g of each of tree bark sample was weighed into 250ml beaker, a mixture of 20ml HNO<sub>3</sub> and 8ml HClO<sub>4</sub> was used to digest the samples on a hot plate in a fume hood to a final volume of 5ml. The digest was cooled, drops of deionised water were added and the solution filtered into a volumetric Flask using whatman No.1 filter paper. The flask was then made up to the 100ml mark with deionised water. The same procedure was carried out on the control tree bark samples. All digest (Soil, tree barks and groundwater) was analyzed for heavy metals using flame atomic absorption spectrophotometer (Buck 210 VGP). All analyses were duplicated to test for reliability of the method and instrument. Recovery study on groundwater samples was also carried out.

### 3.4 Statistical Analysis

The data obtained from the chemical analyses were subjected to statistical treatment using mean, standard deviation and correlation coefficient matrices so as to establish elements association and probable source of pollution. Clustered bar chart was also produced to show element concentration in top soil, tree bark and groundwater.

### 4.0 Results And Discussion

The mean values of physicochemical parameters and that of heavy metals in groundwater samples in comparison with various international standards which include World Health Organisation (WHO), United State Environmental Agency (USEPA), National

Standards for drinking water Quality (NSDWQ) and National Environmental Standards and Regulation Enforcement Agency (NESREA) are shown in Table 1.0. The concentration of most of the quality variables determined are within the permissible limits. Forty two percent (42%) of the groundwater samples analysed had TDS values higher than the NESREA and NSDWQ acceptable limits in drinking water. Although, the mean level of chloride was within allowable limits of 250 mg/L in drinking water, over 64.3% of the water sample studied were with chloride values higher than 40.0 mg/L, suggesting input from salt water intrusion from neighboring water body. All trace metals analysed are also within allowable limit, going by the standards employed except Cadmium (0.004 mg/L) which was that is slightly higher than the WHO allowable limit of 0.003mg/L. Cadmium is one of the pollutant of priority in groundwater assessment and monitoring by environmental protection agency (USEPA, 1982). The average daily intake of cadmium is estimated as 0.15  $\mu\text{g}$  from air and 1.0  $\mu\text{g}$  from water. Although Cd is eventually excreted, however, it is biopersistent and, once absorbed by an organism, remains resident over decades in human system. The major sources of Cd, are atmospheric deposition and through fertilizer application in agricultural soil. Other Physico chemical parameter analysed further reveal the potability of the groundwater in the study area. Toxic metals from cement factories are capable of changing salt content of water, hence seriously disrupt aquatic communities and also decreases quality of water used for drinking and irrigation purposes (Gbadebo and Bankole, 2007). The groundwater studied can be classified as a fresh moderately hard. The alkalinity level of water under investigation belongs to a class in which alkalinity hazard require proper treatment before consumption (Ragunath, 1987). A very weak negative correlation was observed in the matrix of metals in groundwater. This indicates possible varying anthropogenic sources of metals in the aquifer. *PHREEQC*, a computer program was used to generate saturation index (SI), which helps in evaluating degree of equilibrium between water and minerals. Changes in saturation state are useful to distinguish different stages of hydrochemical evolution and help identify which geochemical reactions are important in controlling water chemistry (Coetsiers and Walraevens, 2006). A saturation index less than zero, indicates that the groundwater is undersaturated with respect to that particular mineral. Such a value could reflect the character of water from a formation with insufficient amount of the mineral for solution or short residence time. An index greater than zero, specifies that the groundwater being supersaturated with respect to the particular mineral phase and therefore incapable of dissolving more of the mineral. The SI results of this study shows that groundwater samples were saturated to undersaturated with respect to sulphate  $\text{Cd}(\text{OH})_2$ ,  $\text{CdSO}_4$ , Melanterite ( $\text{FeSO}_4 \cdot 7\text{H}_2\text{O}$ ), while samples were saturated to supersaturated with respect to Otavite ( $\text{CdCO}_3$ ) and Siderite ( $\text{FeCO}_3$ ). The mean values of  $\text{SI}_{\text{Cd}(\text{OH})_2}$ ,  $\text{SI}_{\text{CdSO}_4}$ ,  $\text{SI}_{\text{FeSO}_4 \cdot 7\text{H}_2\text{O}}$ ,  $\text{SI}_{\text{CdCO}_3}$  and  $\text{SI}_{\text{FeCO}_3}$  are -6.28, -8.65, -6.16, 1.31 and 0.65 respectively.

### Soil analyses

The pH of the soil samples analysed ranged from 7.6 to 8.4 with average value of 8.1 (Table 2.0), which is slightly basic. pH plays an important role in metal bioavailability, toxicity and leaching capacity of soil to surrounding areas (Chimuka *et al.*, 2005). Trace metals are known to form complexes with organic matter and this influences their mobility in the soil, Metals readily leach out in acidic pH. (Fatoki *et al.*, 2004). The result showed that the soil samples are within the world range given by Alloway (1995). The results of the concentration of the trace metals measured in top soil samples are given in Table 2.0. The levels of Fe, Ni, Cr and Cd are higher in the soil samples in the vicinities of cement factory than in the controls samples. This point at the impact of the production activities on the environment. Fe was having the highest means concentration of  $91.6 \pm 0.3 \mu\text{g/g}$  of all the metals analysed. The high concentration of the metal has been well documented in literatures (Ogunyemi *et al.*, 2003; Amusan *et al.*, 2005). The mean controls for Cu and Pb were slightly

higher than the samples, this suggests the possibility of other sources, which include automobile emission, urban surface run off and bush burning . Pb is particularly considered to be air pollutant that readily subjected to long distance dispersion from source of emission (Jarmo, 2001), therefore, cement factory (activities) could be a remote source of these metals. This assertion is further revealed going by the trend of metals in the two control locations which reflect the concentration of metals observed as a function of increase in distance from the Ewekoro factory. Results obtained were subjected to correlation coefficient (Table 3.0). Cr was found to have significant correlation (  $p > 0.05$ ) with Ni, Pb, Cu and Fe, strong correlation was also observed between Cu and Pb, Pb and Ni, Cd and Ni and also between Ni and Fe, Mg. this indicated that all these metals are probably from the same source (cement works).

The enrichment factor (EF) of heavy metals in soil was investigated. The EF is calculated by

$$EF = [C_{\text{metal}}/C_{\text{normalizer}}]_{\text{soil}} / [C_{\text{metal}}/C_{\text{normalizer}}]_{\text{control}}$$

Where  $C_{\text{metal}}$  and  $C_{\text{normalizer}}$  are concentration of heavy metals and normalizer in soil samples and control samples respectively. The normalizer in this study is element iron.

Table 1.0: Mean values of Physico-chemical parameters and trace metals in groundwater samples with other international standards.

Parameters	Experimental (mg/L)	WHO (mg/L)	NESREA (mg/L)	NSDWQ (mg/L)	USEPA (mg/L)
Cd	0.004	0.003	0.01	0.01	0.005
Cr	Nd	0.05	0.05	0.05	0.05
Cu	0.054	2.0	-	1.0	1.3
Fe	0.02	0.3	0.3	0.3	-
Pb	Nd	0.01	0.01	0.01	0.01
Ni	Nd	0.02	0.05	-	-
pH	7.0	6.5-8.5	6.5-8.5	6.5-8.5	6.5-8.5
Temperature °C	28	-	-	-	-
TSS	494.9	-	>10	-	-
TDS	421.4	1000	500	500	-
TS	917.0	1500	Nd	-	-
Cl <sup>-</sup>	57.2	250	250	250	100
SO <sub>4</sub> <sup>2-</sup>	19.2	400	500	100	100
Total Alkalinity	180.4	100	500	100	100
Total Hardness	<b>95.3</b>	<b>500</b>	-	-	-

Nd = not detected

The EF helps more importantly to differentiate between metals originating from anthropogenic activities and those from natural processes, as well as assessing the degree of anthropogenic influence (Sutherland et al., 2000). The pollution load Index , PLI was also calculated. PLI helps to evaluate the extent to which the study area under investigation is polluted with metals .It is calculated as follows:

$$PLI = (CF_1 \times CF_2 \times CF_3 \times \dots \times CF_n)^{1/y}$$

Where CF is contamination factor and y is the number of metals analysed

Various methods of calculation have been reported in literatures by various researchers. (Kamar, 2002; Valdés et al., 2005; Ghrefat and Yusuf, 2006; Abraham and Parker, 2008; Akoto et al., 2008) . The EF and CF values are shown in Table 4.0.

Based on Sutherland (2000) classification, all enrichment factor values obtained show minimal enrichment of respective metals except Pb with moderate enrichment. However, contamination factor showed a clearer picture with copper and lead having low contamination in the studied soil , while chromium, cadmium, nickel and iron displayed moderate impact on the environment. The calculated PLI for the study location is 0.86 implying non –contamination. This shows human friendly state of the environment under

consideration. This indicate that pollutants generated from the cement production are mainly air dispersed form.

Table 2.0: Level of trace metal concentration ( $\mu\text{g/g}$ ) and pH of soil samples

Sample Code	Cr	Cu	Pb	Cd	Ni	Fe	pH
Soil 1	0.56	0.95± 0.05	2.01±0.01	0.04±0.001	0.67±0.03	119.07±0.03	7.80
Soil 2	0.42	0.10±0.45	0.64±0.04	0.01±0.002	0.48±0.01	120.80±0.1	7.60
Soil 3	0.11	0.032±0.002	ND	ND	0.08±0.002	42.93±0.1	8.00
Soil 4	0.38±0.02	0.11±0.01	0.51±0.003	0.02±0.003	0.514±0.01	124.76±0.01	8.50
Soil 5	0.54±0.01	0.5±0.01	1.75±0.01	0.053±0.004	0.78±0.02	122.07±0.15	8.20
Soil 6	0.22±0.01	0.04±0.003	0.22±0.02	0.01±0.001	0.18±0.004	32.01±0.1	8.00
Soil 7	0.48±0.03	0.122±0.021	0.57±0.010	0.043± 0.003	0.461 ± 0.001	94.60 ± 0.41	8.30
Soil 8	0.85±0.01	0.200±0.01	0.645±0.01	0.031±0.004	0.406±0.01	3.00±0.07	8.50
Soil 9	0.16 ±0.05	0.252± 0.002	1.00±0.01	0.024±0.001	0.441±0.002	138.6±0.62	8.30
Soil 10	0.705± 0.03	0.214±0.01	1.07±0.01	0.051±0.002	0.815±0.02	119.55±1.3	8.40
Mean	0.44±0.02	0.27±0.06	0.84±0.05	0.03±0.002	0.50±0.01	91.6±0.30	8.16
Contr. 1	0.39	0.58 ± 0.09	1.96± 0.027	0.027	0.43	88.05	7.80
Contr. 2	0.31	0.49 ± 0.032	1.73 ± 0.071	0.022	0.38	86.28	8.00
Normal range in soil	5 - 1500	2 - 250	2 - 300	0.01 - 2.0	5 - 500	7 - 550	-

ND = not detected

Table 3.0: correlation coefficient matrix of metals in soil

	Cr	Cu	Pb	Cd	Ni	Fe	Mg
Cr	1.0						
Cu	<b>0.6</b>	1.0					
Pb	<b>0.7</b>	<b>0.9</b>	1.0				
Cd	<b>0.5</b>	0.2	0.4	1.0			
Ni	<b>0.8</b>	<b>0.5</b>	<b>0.7</b>	<b>0.8</b>	1.0		
Fe	<b>0.6</b>	0.3	<b>0.5</b>	0.3	<b>0.7</b>	1.0	
Mg	0.2	-0.3	-0.02	0.4	<b>0.6</b>	0.4	1.0

Table 4.0: Enrichment factor and contamination factor of metals in soil

Metal	Cu	Cr	Pb	Cd	Ni	Fe
EF	1.17	0.84	2.31	0.88	0.86	1.00
CF	0.47	1.25	0.45	1.20	1.22	1.05

### Tree bark analyses

The mean value of the metals investigated in tree bark samples is shown in Table 5.0. The results obtained showed more abundance of Mg, compared to other metals analyzed, with cadmium having the lowest concentration. The surface structure of a tree bark has considerable influence on the rate of accumulation of metals. Literatures of past related works have established that, a tree bark, with a coarse, rough surface more readily absorb atmospheric pollutants more than a smooth surface (Jarmo, 2000). Bark is exposed to pollutants either directly from the atmosphere or from stem flow. Level of bark metals in this study was found to be lower than the normal toxicity range given by Bowen (1979) as shown in Table5.0.

Generally, all the environmental samples analyzed showed considerable level of Mg. The high levels of Mg might as a result of contributions from other sources such as agricultural run-off and geological formation of the area. Mg however shows weak correlation



( $p < 0.05$ ) with Cr, Cu, Pb and Fe in all the samples analyzed. Strong and positive correlation were observed in Ni/Mg, Ni/Cr, Mg/Cd, Pb/Cd, and Fe/Pb (Table 6.0) implying that these paired metals are from the same source (Cement works). Plants accumulate metals from the soil via their roots system and transport to other parts of the plant. They (Plants) can also accumulate metals from atmospheric deposition through folia absorption or its bark. Jarmo, 2000 investigated Cd, Cu, Ni and Pb uptake in air and soil by milfoil and barley, he however concluded that Ni and Cd content in the plants correlated with deposition and soil content. Although the concentrations of all the metals analyzed in the environment samples are within threshold limits, accumulation may result to serious health problems. Deposition of these metals from cement on herbaceous plants and fruits crops can cause effects such as blocking leaves stomata, reduced number of plant leaf and reduction in vegetative growth and reproduction structure (Gbadebo and Bankole, 2007). The use of tree bark as herbs, eating raw fruits without thorough washing is a common practice particularly in Africa, these constitute direct route of metals to metabolic pathway of man (Majolagbe et al., 2011). Trace metals indeed play important roles in biochemical processes, being essential component of molecular structure, therefore, participate in processes such as enzyme regulation and gene expression. However, various toxic effects are induced at elevated level.

Table 5.0: Normal and phototoxic levels ( $\mu\text{g/ml}$ ) of metals in plant bark

Elements	Normal range	Toxicity range	Experimental value
Cd	0.1-24	5-30	0.014
Cu	5-10	20-100	0.390
Cr	NS	NS	0.332
Pb	5-10	30-310	0.276
Ni	0.02-5	10-100	0.237
Mg	NS	NS	7.17
Fe	NS	NS	1.49

NS = not stated

Table 6.0: Correlation inefficient matrix of analyzed metals in tree bark samples

	Cr	Cu	Pb	Cd	Ni	Fe	Mg
Cd	1.0						
Cr	-0.3	1.0					
Cu	0.2	0.2	1.0				
Fe	0.02	0.0004	<b>0.6</b>	1.0			
Pb	-0.01	-0.12	-0.3	<b>0.8</b>	1.0		
Ni	<b>0.8</b>	-0.32	0.111	0.4	0.3	1.0	
Mg	-0.3	0.01	-0.1	<b>0.6</b>	<b>0.9</b>	-0.1	1.0

## Conclusion

This study presented the level and distribution of trace metals in environmental media (soil, groundwater and tree barks) in the vicinities of cement production area (WAPCO), Ewekoro, southwest, Nigeria. All the metals investigated were found present in the three environmental media under consideration, at a contamination level. The study reveals more of pollutants that are air bound than that of soil and water. Trace metal such as cadmium and iron were observed higher than the allowable limit in groundwater. This portends a serious health threat to the inhabitants of this community, whose groundwater is the main source of water for drinking and domestic needs. Although, the PLI value is implying human friendly status of the study location, but the EF is warning of the possible build up of metals particularly Pb.

The continuous accumulation of these metals, if not checked could result in pollution status with possible lethal effect to both terrestrial and aquatic organisms within the environment and beyond. Hence, the need for strict compliance on environmental rules and regulation by the cement production factory, to ensure safety of man and the environment.

**References:**

- Abraham G.M.S., and R.J. Parker. Assessment of heavy metal enrichment factors and the degree of contamination in marine sediments from Tamaki Estuary, Auckland, New Zealand. *Environ. Monit. Assess.* 136: 227–238, 2008.
- Akoto O., J.H. Ephraim, G. Darko. Heavy metal pollution in surface soils in the vicinity of abundant railway servicing workshop in Kumasi, Ghana. *Int. J. Environ. Res.* 2(4): 359–364, 2008.
- Amusan, A. A., D.V. Ige, and R. Olawale. Characteristics of soils and Crops uptake of metals in Municipal waste dumpsites in Nigeria. *J. Hum. Ecol.* 17(3):167 – 171, 2005.
- APHA / AWWA / WPCF. Standard Methods for the Examination of Water and Wastewater. 20th ed. Washington, APHA / AWWA / WPCF, 1998.
- Bowen, A.O. Normal and Phytotoxic level of metals in plants leaves and barks. *Journal of Environment quality.*7: 27, 1979.
- Chimuka, L. and O.O. John. Metals in environmental media: Study of trace and platinum group metals in Thohoyandou, South Africa. *Water S.A.* 31: 581-586, 2005.
- Coetsiers, M. and K. Walraevens. Chemical characterization of the Neogene Aquifer, Belgium,” *Hydrogeology. Journal*, 14: 1556–1568, 2006.
- Department of Environmental (DOE). Analysis of Raw, Portable and Wastewaters. London, Department of Environmental (DOE), pp 12-16, 1972.
- Fatoki, O. S., Z. Mbolekwa, and O.R. Awofolu. Levels of trace metals in water and sediment from Tyume River and its effects on an irrigated farmland. Alice, South Africa. *Water S.A.* 31: 87, 2004.
- Folinbee L. J. Human effects of air pollution. *Environ. Health perspective*, 100:45-46,1993.
- Gbadebo, A. M and O.D. Bamkole. Analysis of potentially toxic metals in airborne cement dust around Sagamu, southwest ,Nigeria. *Journal of applied science.* 7(1):35-40, 2007.
- Ghrefat H, and N.Yusuf. Assessing Mn, Fe, Cu, Zn and Cd pollution in bottom sediments of Wadi Al-Arab Dam, Jordan. *Chemosphere* 65: 2114–2121, 2006.
- Jarmo, P. Heavy metals loading in tree barks, Mosses and Lichen Forest condition in a changing environment. The Finnish case study, the Finnish forest research institute, Oulu, Finland. *Forest sciences* 65:16,25,2001.
- Kehinde-Phillips, T. Ogun State maps. Rex publisher, Ibadan, pp187, 1992.
- Knight, C. and J. Kaiser. Heavy metals in surface water and stream sediments in Jamaica. *Envi. Geochemistry and health, Kingston Jamiaca .Chapman and hill publishers,Kingston.*19:63-66, 1997
- Kumar, D., Khare, M. and Alappat, B. J. “Threat to groundwater from the municipal landfills in Delhi, India”, In: Proceedings of the 28th WEDC Conference on sustainable environmental sanitation and water services, Kolkata (Calcutta), pp. 377–380, 2002.
- Liu, O. M, Salmijah, S.,Ismail, B.S. and Aminah, A.The impact of Traffic causing Lead Exposure to Malaysian school children. *Global Journal environmental Research* 1(2):43- 48, 2007.
- Majolagbe, A.O., Kasali, A.A., and Ghaniyu, L.O. Quality assessment of groundwater in the vicinity of dumpsites in Ifo and Lagos, Southwestern Nigeria. *Advances in Applied Science Research*, 2(1), pp. 289-29, 2011.
- Miranda, M , Lo´pez-Alonsob, M. Castillob, C. Herna´ndezb, J. Beditob J.L. Effect of moderate pollution on toxic and trace metal levels in calves from a polluted area of northern Spain. *Environmental International.* 31 :543-548, 2005.
- Mishra S, Srivastava S, Tripathi R.D, Kumar R, Seth, C.S and Gupta, D.K. Lead detoxification by coontail (*Ceratophyllum demersum* L.) involves indication of phytochelatin and antioxidant system in response to its accumulation. *Chemosphere* 65(6):1027–1039, 2006.

- National Guidelines and Standards Drinking Water Quality. NESREA Publications, Federal Ministry of the Environment 5 (3) :54,2005
- Ogunyemi S, Awodoyin, R.O., Opadeji, T. Urban Agricultural Production: HeavyMetal and multivariate assessment of contamination sources. *Chemosphere* 74: 491–495, 2003.
- Okoronkwo, N. E., Odemelam, S.A. and Ano, A.O. Levels of Toxic elements in soil of abandoned dumpsite. *African Journal of Biotechnology*. 5:1241 – 1244, 2006.
- Omosola, M.E. and Adegoke, O.S. Tectonic evolution and cretaceous stratigraphy of the Dahomey Basin. *Journal Mineral Geology* 18:130-137, 1981.
- Protano, G., Riccobono, F., and Sabatini, G. Does Salt Intrusion Constitute a mercury contamination risk for coastal fresh water aquifers? *Environmental Pollution*,110, pp. 451-458,2005.
- Ragunath, H.M. *Groundwater*. New Delhi, Wiley Eastern Ltd., p. 563, 1987.
- Riordan, J.R. Handling of heavy metals by cultured cells from patients with Menke diseases. In Sarkar, D (eds.) *Biological aspects of metals related disease*. Raven Press, New York, pp 159- 70, 1983.
- Sutherland, RA, Tolosa, C.A., Tack, F.M.G., Verloo, M.G. Characterization of selected element concentration and enrichment,2000.
- Tahawy,El.M.S., Hanningan,R.,Nassef,M.and Sayed,El.K.A. Determination of some heavy metals in the environment of Sadat industrial city. Faculty of science, Cairo university, Egypt. Proceeding of the 2<sup>nd</sup> environment physics conference,18-22 feb.Pp.145,146,151,2006.
- United States Department of agriculture (USDA). *Soil Quality –Heavy metal soil contamination*. Urban technical note No 3.s,2000.
- United States Environmental Protection Agency, USEPA. *Aquatic Fate process Data for Organic priority pollutant*. Office of Water regulation and Standards.Washington, DC 20460,1982.
- Valdés J, Vargas G, Sifeddine A, Orttlieb L, Guíñez M. Distribution and enrichment evaluation of heavy metals in Mejillones bay (23°S), Northern Chile: geochemical and statistical approach. *Mar. Pollut. Bull.* 50: 1558–1568,2005.

# APPROACH UNDER THE FORM OF SEMIQUANTITATIVE CYTOLOGICAL EVALUATION FOR CHRONIC PHARYNGITIS

**Lydia Ferrara**

Department of Pharmacy, University of Naples, "Federico II", Naples, Italy

**Daniele Naviglio**

Department of Chemical Sciences, University of Naples "Federico II", Naples, Italy

**Arturo Armone Caruso**

Tech. Director, General Manager of ENT Department at AIAS Structure of Afragola, Italy

---

## Abstract

In this study, we propose a semi-quantitative evaluation form for diagnosis of chronic pharyngitis based on both subjective and objective parameters. The data collection symptom of patients together with the microscopic evaluation of the cytological specimen allows to diagnose with a high degree of certainty the severity of the inflammatory state of the pharynx. This assessment is certainly very important for the evaluation of therapeutic treatment in relation to the severity of the disease

---

**Keywords:** Pharyngitis, pharyngeal cytology, evaluation form, Papanicolaou test

## Introduction:

Chronic pharyngitis is a condition of infection (bacterial or viral) or irritation (chemical or physical) type that involves the inflammation of the pharyngeal mucosa persistent for at least one year, for more than six hours a day, for more than two weeks a month, for more than three months a year.

From a clinical point of view are known three forms of chronic pharyngitis

- *single or catarrhal*: pharyngeal mucosa diffusely reddened, swollen, with evident lymphoid follicles, covered with catarrhal exudate, more or less abundant and fluid;
- *hypertrophic*: bright red pharyngeal mucosa, thickened and irregular due to the presence of enlarged, red-violet lymph follicles, with traces of catarrhal or mucopurulent exudate;
- *atrophic*: dry, smooth, shiny, pink or red pharyngeal mucosa, without detectable lymph follicles, with traces of mucopurulent exudate dry or congealed into scabs.

Subjective symptoms of chronic pharyngitis are:

- irritation of the throat, which can be referred as a feeling of dryness/discomfort/sting;
- hoarseness;
- sensation of postnasal drip or sensation of presence of retronasal secretions that can compel the patient to repeated acts of clearing the throat;
- sensation of constriction or sensation of foreign body, which may intensify in swallowing of saliva, while it is less felt when swallowing solid food or liquids.

Objective symptoms of chronic pharyngitis are:

- congestion of the pharyngeal mucosa (rear wall, soft palate, uvula, palatine pillars);
- presence of mucopurulent or catarrhal secretion, fluid or clotted scabs;

- evidence of lymphoid follicles present on the rear wall (hypertrophic forms) or atrophy of the mucosa which appears dry, smooth, shiny (atrophic forms).

The microscopic examination of the normal pharyngeal mucosa shows a layer of stratified squamous epithelium, not horny, surrounded by vascularized fibrous connective tissue. In pharyngeal chronic inflammation, the microscopic morphological picture is characterized by hyperemia and edema of the mucosa, chorion transudate with formation of corpuscular, full of exudate lymphocytes; epithelial lining is hypertrophic and hyperplastic onset, while in the chronic phase it undergoes progressive atrophy that also involves the glandular formations. For this reasons, many authors have established therapeutic modalities to achieve both clinical improvement cytomorphological<sup>1</sup>.

From the point of view of etiopathogenic, the deterioration of the pharyngeal mucosa is in part due to an alteration in physiological mucous secretion. The latter is produced in the entire cavity, along the tracheobronchial tree and in the pulmonary alveoli<sup>2</sup>

The mucus are a heterogeneous mixture and changes of its composition are responsible for:

- changing the normal physiology of the tissue;
- respiratory system in a daily amount of 100 mL which spreads and stratifies from the nasal destabilizing the balance that the resident bacterial flora establishes with the microenvironment;
- triggering inflammatory processes and immunoallergic reactions;
- activating repair processes induced by physic-chemical trauma<sup>3</sup>

With the aim to observe cytologic changes above reported and in order to achieve a therapeutic and predictive most suitable, an observational study using an optical microscope with a magnification of 60x to dry was performed. In survey are taken into account both the morphological changes associated with degeneration, both repair (Fig. 1). The observations can be summarized in the following table<sup>4</sup>

Degeneration	Reparation
a) bluning of chromatine, breakdown of nuclear membrane, cytoplasmic vacuolation	e) nuclear enlargement, prominent nuclear border
b) nuclear shrinkage and condensation of chromatine (Karyopyknosis)	f) multinucleation
c) nuclear fragmentation and agglutination of chromatin (Karyorrhexis)	g) slight corseting of cromatin, slight nuclear hypocromasie, undulation in the nuclear membrane
d) almost complete dissolution of nucleus (Karyolysis)	h) prominent nucleoli

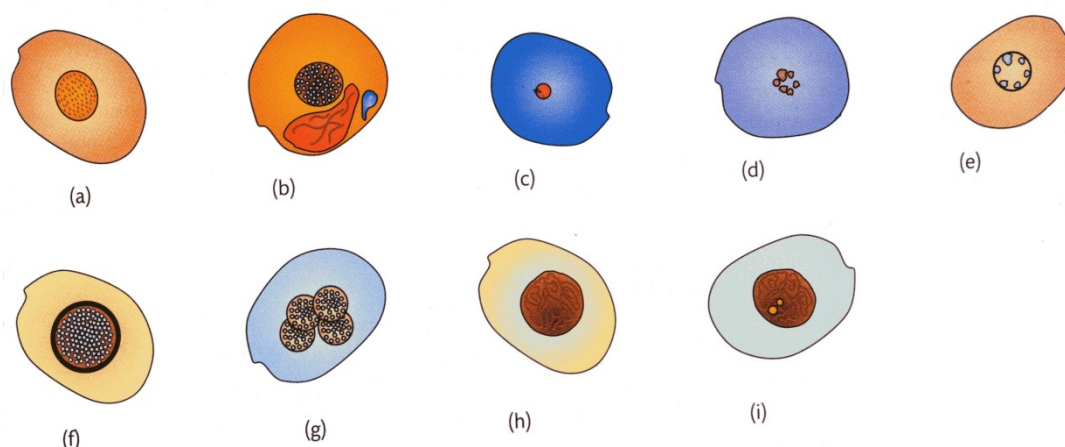

**Fig 1. Diagrammatic representation of cells undergoing degeneration (a-e) and repair (f-i)**

## Materials and Methods

The study was conducted by selecting 20 subjects, related to the surgery ENT diagnostic AIAS Afragola in collaboration with the University of Naples "Federico II". and the hospital "Vincenzo Monaldi". The criteria for inclusion powers: a history of chronic pharyngeal pathology and physical examination suggestive of chronic pharyngitis. Were excluded from the study patients showing the following symptoms: systemic diseases, pregnancy and lactation, GERD (gastro esophageal reflux disease), oncological diseases, pharmacological treatment for chronic pharyngitis in the last 30 days. The selected subjects who joined the study were 20 patients aged between 20 and 60 years, mean age 25.5, 15 males, 5 females (group A). As a point of reference we have examined a homogeneous group composed by 20 healthy subjects (group B).

The path to follow-up was performed by a history-taking and physical examination is was performed through direct observation, and by means of a fiberscope to assess the state of the mucosa. Subsequently the patients compiled the form of enlistment in which were evaluated the following subjective symptoms:

- Direction of itchy throat
- Hoarseness
- Pain
- Odynophagia
- Cough
- Otalgia

An intensity scale (0: absent, 1: moderate 2: intense, 3: very intense) was associated with symptoms reported above. Then exfoliative cytology, practiced by Ayre spatula modified by us was performed using the convex side of the spatula, to increase the amount of cells to be taken. The withdrawn exfoliated cells were affixed on both a microscope slide, in a standardized space, and fixed. Subsequently they were stained with the Papanicolaou test.

In the observation the following parameters were evaluated: the number of squamous cells and pathological conditions, their relationship with the total number of cells and the presence of inflammatory cells; possible inclusions of keratin, as well as the presence of bacteria. These aspects have been recorded and analysed by an evaluation board and created specifically covered by this report TAB 1.

The statistical analysis was performed using Wilcoxon Two-Sample Test (t approximation); significance level was set at 0.05 ( $p < 0.05$  was considered as statistically significant).

Control group (B) was undergone to the same protocol of analysis.

## Discussion

The aspects that were analysed were related to cell tropism and specifically to the relationship between the squamous cells and the total number of cells. Furthermore, the presence of inflammatory cells, characterized by the presence of neutrophils, and any inclusions of keratin, as well as the presence of bacteria were evaluated. These aspects, as previously mentioned, were recorded and analysed by an evaluation board created for the scope and object of this report. It was divided in the two groups, and shows a comparison of the subjective symptoms and the cytologic detection. Data reported in Table 1 show the following results:

- 3 cases: rare cells, rare neutrophils, lymphocytes. Ratio <100% score 1;

- 10 cases: some squamous cells, neutrophils, lymphocytes. Ratio <100% score 2;
  - 6 cases: numerous squamous cells, neutrophils, lymphocytes. Ratio <100% score 3;
  - 1 case: numerous squamous cells, neutrophils, lymphocytes. Ratio <100% score 3
- For patients in group B was noticed generally, the absence of pathological cells and inflammatory cells Ratio = 100% Score 0.

**FORM OF PHARYNGEAL CYTOLOGY:  
LEGEND OF SEMIQUANTITATIVE EVALUATION**

Name \_\_\_\_\_ Date \_\_\_\_\_ Time \_\_\_\_\_  
Surname \_\_\_\_\_

Total Cells (CT)	0 NR	Microscopic Fields 400- 600 * x																			
		+ (rare)					++ (some)					+++ (many)					++++ (very many)				
Squamous Cells (CS)	0	20	20	20	20	20	20	20	20	20	20	20	20	20	20	20	20	20	20	20	20
Pathological Cells (CP)	0	20	20	20	20	20	20	20	20	20	20	20	20	20	20	20	20	20	20	20	20
Regenerative change	0	20	20	20	20	20	20	20	20	20	20	20	20	20	20	20	20	20	20	20	20
Degenerative change	0	20	20	20	20	20	20	20	20	20	20	20	20	20	20	20	20	20	20	20	20
Neutrophils	0															20	20	20			
Lymphocytes	0																				
Bacteria	0																				
Spores	0																				
CP/CT x 100		> 100%					< 100%					= 100%					Inclusions O S. B. /F O INTRA O EXTRA O				

**TAB 1**

LEGEND: : \*indicate the magnification used ; Cell count: 20groups / 50 fields; lymphocytes, neutrophils, bacteria, spores single/50 fields; CP / CT % =ratio% abnormal cells / total cells.Inclusions: SB/F = Bacterial or fungal spots; Intra= Intracellular bodies ;Extra=extracellular bodies

**Conclusion**

The study carried out allowed us to perform a precise assessment of cytology symptoms in a form of disease that is usually diagnosed through a physical examination and a subjective evaluation. The consequence of applying subjective evaluation is can be that the therapeutic procedure may be susceptible to changes (depending on evaluator) or it can result in a failure. In light of the foregoing, the cytological investigations corroborated by subjective evaluations, allow us to establish that they are a crucial element for the evaluation of the forms of pharyngitis in an objective manner.

In fact, the proposal of a semiquantitative table could be not only an element of classification of the pharyngitis in mild, medium, severe and very severe forms (due from the count of the elements and inflammatory disease), but it could be a tool for the evaluation of a therapeutic treatment.

**References:**

Lingen MW., Brush-based cytology screening in the tonsils and cervix: there is a difference!, 2011  
 Rubin BK, Physiology of air way mucus clearance. Resp. Care. 2002.  
 Fahy JV. et al., Airway mucus function and dysfunction. N. Engl j. Med. 2010.  
 Cytopathology. Ed. B. Shambayati, Oxford University

# **IN VIVO ASSESSMENT OF GROWTH PROMOTING ACTIVITY OF A SYNTHETIC b-FGF IN WOUND HEALING OF RAT'S SKIN**

***Ayoub A Bazzaz***

Department of Biology, Faculty of Science,  
University of Taibah, Al-Madinah Al-Munawara, KSA

***Fatin O Bukhari***

Medical School, University of Taiba, Al-Madinah Al-Munawara, KSA

***Zumrud A Bazzaz***

Lloyds Pharmacy, ASDA, West Lane, UK

***Noorhan A Chelebi***

Department of Biochemistry, Institute of Integrative Biology, University of Liverpool, UK

---

## **Abstract**

A single 0.3µg/mL of synthetic b-FGF topical dose was applied *in vivo* on a model of freshly made twin scalp wounds of 8 mm length in full dermal thickness skin of 20 male albino rats *Rattus norvegicus* under anesthesia, while an adjacent wound was washed only with phosphate buffer saline (PBS) as an untreated or control. The rats at different times i.e. 15 minutes-10 days were then dissected under anesthesia and perfused with 10% formalin fixative in PB in 0.1M PB of pH7.4 through the left ventricle. Skin samples of both wounds were then processed using routine histology technique and stained with Heamatoxylen and Eosin (H&E) as well as for antibodies raised against substance-P. The morphological observations showed a significantly early closure (50% time scale) of the wounds topically treated with b-FGF at day two in comparison with those of controls of the same individual animals. Histological results had confirmed the potency of the 0.3 ng/mL dose of b-FGF in inducing a rapid, almost in half healing time via re-epithelialization, a rapid maturation of newly formed fibers, angiogenesis, contraction and significantly accelerated the wound closure time of treated rats to almost half time in comparison with controls. The single low dose topical application of b-FGF had accelerated the proliferation process of skin tissue components confirming its curing potency for both pharmaceutical industry and in medicine in curing skin wounds.

---

**Keywords:** *In vivo*, scalp wound, synthetic FGF, skin healing

## **1. Introduction**

For a few decades, the scientists, worldwide are developing ways to accelerate injury healing and to hinder the aging process by growing new skin faster. Synthesized growth factors (GFs) are one of medication being adopted to maintain skin's youth and to help in wound healing. Extracted from cultured epidermal cells, placental cells, colostrums, and even plants, GFs are compounds that act as chemical messengers between cells, turning on and off a variety of cellular activities. The GFs increase the rate at which cells in the body grow and play a role in cell division, new cell and blood vessel growth, collagen and elastin production (Finklestein and Plomaritoglou, 2001).

While in normal skin, the epidermis and dermis exists in steady-state equilibrium, forming a protective barrier against the external environment wound healing is an intricate



process in which the skin repairs itself after injury (Nguyen *et al.*, 2009). Once the protective barrier is broken, the normal process of wound healing is immediately set in motion. Depending upon the size and the depth of the wound, surgical intervention may sometimes be needed to accelerate healing process. In such cases, a complex repair process begins instantly which may continue for longer time leaving sometimes prominent scars (Martin and Leibovich 2005). Skin healing does start immediately following the injury while bleeding accompanies the injury due to ruptured blood vessels and blood plasma provides antibodies to the wound to attack various microbial germs. It would also supply it with blood platelets to help coagulate the blood around the wound itself. Although this process is extremely efficient, there are always risks of infection and particularly when the wound is large, where the consequent scarring can be hard and big without stitches. Scientists are keen to find ways to accelerate wound healing while keep them well protected from germs (Martin, 2001).

Healing of wounds, involves the activity of an intricate network of blood cells, tissue types, cytokines as well as GFs. This results in increased cellular activity, which causes an intensified metabolic demand for nutrients. The classic model of wound healing, in general, is divided into 3 or 4 sequential (Quinn, 1998), yet overlapping: phases: 1). *hemostasis*; 2). *Inflammatory*; 3). *proliferative* and 4). *Re-modeling*. Upon injury to the skin, a set of complex biochemical events does also take place in a closely orchestrated cascade to repair the damage (Stadelmann *et al*, 1998; MacKay *et al*, 2003). However, as a first step and within minutes post-injury, platelets aggregate at the injury site to form a fibrin clot which acts to control active bleeding which occurs within minutes of the initial injury unless there are underlying clotting disorders.

In human, inflammation, presents as erythema, swelling and warmth often associated with pain may usually lasts up to 4 days post injury. Within an hour of wounding, polymorphonuclear Neutrophils (PMNs) arrive at the wound site and become the predominant cells for the first two days after the injury, with especially high numbers on the second day. Neutrophils phagocytise debris and bacteria, by releasing free radicals in what is called a "respiratory burst" (Muller *et al*, 2003). Inflammation can lead to tissue damage if it lasts too long therefore; reduction of inflammation is frequently a goal in therapeutic settings (Midwood *et al*, 2004). In human, about 2-3 days after the wound occurs, fibroblasts begin to enter the wound site, marking the onset of the proliferative phase even before the inflammatory phase has ended (Falanga, 2005). As in the other phases of wound healing, steps in the proliferative phase do not occur in a series but rather partially overlap in time. Investigation of the length of this phase has not been challenged in rats.

Angiogenesis occurs concurrently with fibroblast proliferation when endothelial cells migrate to the area of the wound. Simultaneously, fibroblasts begin accumulating in the wound site in human, 2-5 days after wounding as the inflammatory phase is ending and their numbers peak at 1-2 weeks post-wounding (*de la Torre* and Sholar, 2006). Fibroblasts then deposit ground substance into the wound bed and later collagen, which they can adhere to for migration (Rosenberg and *de La Torre* 2006). The formation of granulation tissue in an open wound allows the re-epithelialization phase to take place, as epithelial cells migrate across the new tissue to form a barrier between the wound and the environment. If the basement membrane is not breached, epithelial cells are replaced within 3 days by division and upward migration of cells in the *stratum basale* in the same fashion that occurs in uninjured skin (Romo and Pearson, 2005).

GFs stimulated by integrins and MMPs cause cells to proliferate at the wound edges. Keratinocytes themselves also produce and secrete factors, including GFs and basement membrane proteins, which aid both in epithelialization and in other phases of healing (Bayram *et al*, 2005). GFs are also important for the innate immune defense of skin wounds by stimulating the production of antimicrobial peptides and Neutrophil chemotactic cytokines in keratinocytes (Sørensen *et al*, 2006). Contraction occurs without myofibroblast

involvement get stimulated by GFs, differentiate into myofibroblasts, which are responsible for contraction (Mirastschijski *et al*, 2004). The contraction stage in proliferation ends as myofibroblasts stop contracting and commit apoptosis (Hinz, 2006). These events signal the onset of the maturation stage of wound healing. Recently, it was found that wound contraction is attenuated by fasudil inhibition of Rho-associated kinase (Bond *et al*, 2011). In summary, the process of contraction of any wound depends on several factors i.e. size and type of the wound, depth, location, healing speed etc. The phases of wound healing normally progress in a predictable, timely manner; but if they do not, healing may progress inappropriately to either a chronic wound (Midwood *et al*, 2004) i.e. a venous ulcer or pathological scarring i.e. a keloid scar (O'Leary *et al*, 2002; Desmouliere *et al*, 2005).

Injuries are accompanied with pains and substance-P (s-P) which is an important element in pain perception (Khalil and Helme, 1995). It is proposed that this release is involved in neurogenic inflammation which is a local inflammatory response to certain types of infection or injury and that s-P's expression in the injured tissues would indicate their role in the pain and intensity at healing process.

Many researches tackled the role of EGF during the wound healing and several EGF are produced on industrial scales for human wound application (Yip and Chahl, 2001). In general, GFs have been used extensively in the medical industry for treating wounds, as topical application has been shown to facilitate faster and more complete healing. The basic fibroblast growth factor (b-FGF) encountered in this research is obtained from tissue culture laboratories as a pure product mainly used for *in vitro* experiments. The aim of this study was to *in vivo* assess the effects of a single topical application of a newly synthesized b-FGF on morphological features of the skin tissues and the healing speed rate of the wound in rat skin (Bazzaz *et al*, 2012).

## 2. Materials And Methods

Twenty healthy Albino male rats were used and full depth of skin wounds of 8.0mm length were made at scalp by a sharp razor upon anesthetizing the rats with chloroform inside a plastic box to relief pain. Two twin wounds per rat (right as control and left as experimental) were made per animal. Normal PB was applied directly to the control wound while a single dose of 80  $\mu$ L of the dose 0.3  $ng/mL$  b-FGF was topically applied to the left wound. The rats were returned to the cages for recovery and covered immediately with a thick handkerchief post-operation to keep them warm under close observation by naked eyes. Animals were dissected at different time schedules i.e. 1/2 hrs, 1, 2, 4, 8, 16, 24, 2 days, 4, days, 8 and days and fixed using 10% in 0.1M phosphate buffer (PB) via cardiac perfusion technique (Bazzaz and Chelebi, 1998) following anesthesia and the patches of the wounds were dissected out and placed in the same fixative for overnight post fixation. They were then impregnated and mounted in paraffin wax. Thin sections of 5  $\mu$ m were cut from each block and collected on a clean glass slide. Sections were then stained in Haematoxylin and Eosin (H&E) as in routine technique for histology.

For immunohistochemistry, 5  $\mu$ m sections were de-waxed in Xylene (2x5 mininuts) then dipped into first 100% ethanol 2x2 minutes followed by the second 96% ethanol (1x2 minutes). Endogenous enzymes are blocked by using (360ml methanol + 6ml hydrogen peroxide [ $H_2O_2$ ]) for 30 minutes. Samples were washed by distilled water (2 x 5 minutes). Sectioned are pretreated by dipping them into citrate pH 6.0 for 30 minutes inside water bath (96-98°C), cooled for 20 minutes then washed by distilled water. Slide were held into racks inside the *Squenza* then washed with (Tris buffer saline (TBS) for 5 minutes. Swine serum of 1:2 in TBS is used for 10 minutes to block the endogeneouse enzymes background from the background. Primary antibodies of Rabbit anti-s-P (Acris BP823) of 1:100 in 20% swine serum in TBS 4°C was used to overnight incubate the section in. The following day, slides were washed with for 5 minutes. Secondary antibody of Polyclonal Swine Anti-Rabbit (Dako

Z0196), of 1:100 in 20% swine serum in TBS 30 minutes, followed by washing them up with TBS for 5 minutes. Peroxidase Anti Peroxidase (PAP) Rabbit (Covance SMI-4010L) of 1:250 in 20% swine serum was used in TBS for 30 minutes TBS then washed for 5 minutes 4x in distilled water. Diaminobenzidine, (DAB 0.2g in Imidazole Buffer, filtered 10 minutes) was used to develop the sections followed by washing with distilled water for (3x5 minutes each), counter-satined in haematoxylin for 1 min “Blue” and washed in tap water 5 minutes. Sections were then dehydrated (1 min 100% ethanol for 2 minutes] then by second 2 minutes 100% ethanol, followed by 2 minutes first 100% xylene then second one for 3 minutes 100%) as in routine histochemical technique. Sections were then cleared by xylene, mounted & cover-slipped with DPX.

## 2. Results

### 2.1 Morphological Observations:

No clear cut clotting on both control and experimental wounds were observed up to the first 30 minutes post-injury by naked eyes. Morphologically, wounds at the early stages of incision and treatment at around 15-30 minute gaps were clear between both sides of each wound. Bleeding had started in both wounds of control and treated sides of each animal; however, both were washed out by either PBS or b-FGF solution (Fig. 1A). However, clotting had established gradually over each wound as indicated in (Fig. 1B). In two hours post-incision, treated injuries showed early symptoms of curing as clean wounds with very little clots or none while the sides of it revealed early signs of closure in comparison with that of control injuries which in turn showed traces of clots and unsealed injury sides (Fig. 1C).

As the time lapsed, the treated wounds showed more affinity to cure faster by narrowing the width of the wound at 4 hours (Fig. 1D) then signs of size reduction as early as 8 hours from both sides and from the two ends reducing the length of the wound almost 25% (Fig. 1E). At by 24 hours both ends became closer [around 50 mm length] (Fig. 1F). On day 2, the control injuries showed some blackened-red clots on with some irregularity of the wound while the treated with less yellowish clot almost closed sides with new connective tissues had developed binding both sides of the straight wound (Fig. 1G). On day 4 the injuries of the treated side showed almost a complete healing process while the control injuries were still recovering (Fig. 1H). By day 8, both treated and untreated injuries were completely healed with no scars noticeable (Fig. 1I).

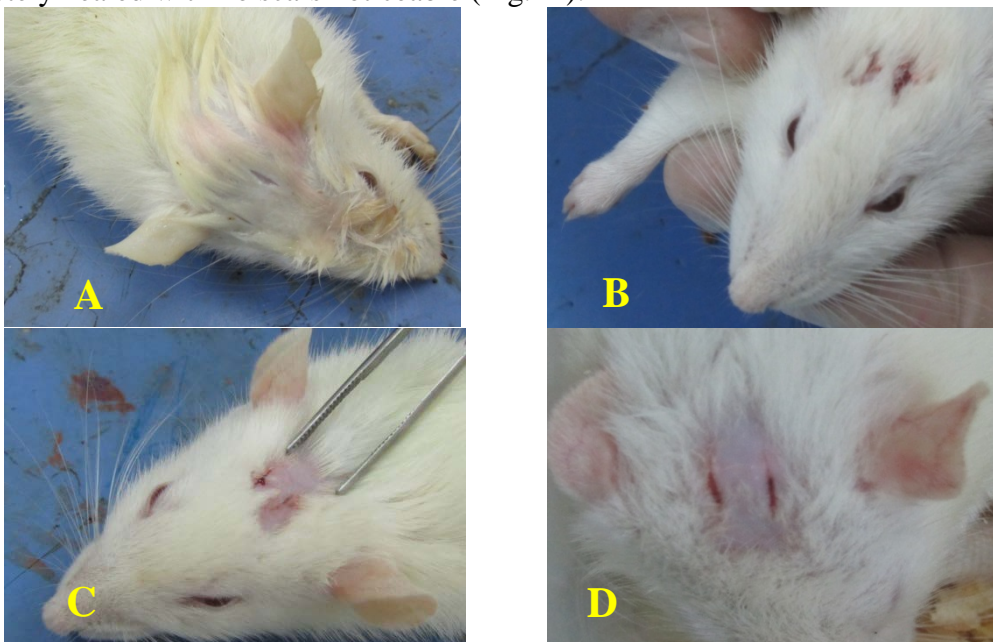

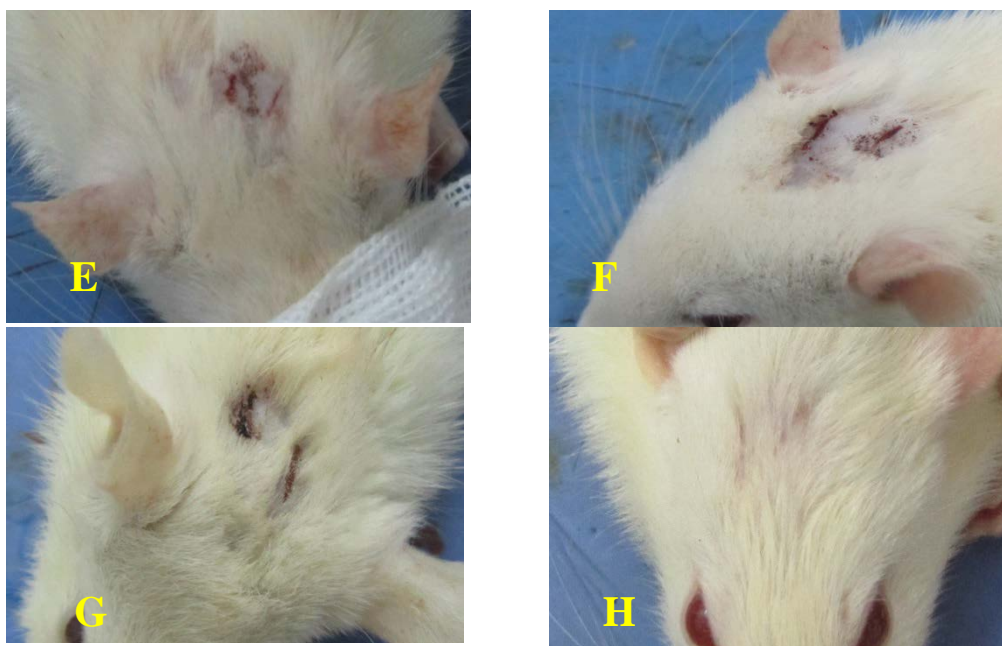

Fig. 1: (A). 15 minutes post-injury shows twin full depth incisions in the rat scalp. Right wound is control (PBS only) and left is treated with 0.3ng/mL FGF; (B): 1hr shows both wounds are covered with clots. The amount of callus on treated wound is more than the control; (C): 2hrs the control developed clot while the treated has not (D): 4 hrs; control is clotted with wider wound while the treated is narrower with no clot. (E): 8 hrs with full depth incision; (F): 24 hrs, almost 50% reduction in the size of treated wound while control showed no signs of contraction. Fewer clots are seen over the treated in comparison with the treated; (G): At 48 hrs treated wound with yellowish plasma clot while control with blackened red-clot. Note the contraction of both sides of the wound in treated while the control shows some irregularity and (H): 4 days post-incision shows an almost completely healed wound with no scars of the treated while a small scar of the healed injury is noticeable at control side.

### 3.2 Histological Observations:

Light microscopic examinations of wound sections had shown full equal depths through both epidermis and dermis down to hypodermis of both control and treated injuries of each individual animal.

#### *Early minutes of injury:*

During the first 15 minutes post-injury, the skin incision had revealed an early phase of hemostasis prior to inflammatory phase. The bilateral distance of the injury, involving epidermis and underneath collagen fibres are set apart with a few cut blood capillaries [Fig. 2A]. The early signs of inflammatory phase has onset by early accumulation of *Polymorphonuclear Neutrophils* (PMNs) spreading through the matrix indicating the perivascular inflammatory infiltration. The PMNs in Experimental wound recorded less (++) than of the control (+++). The immune-histochemical sections of s-P cells expressed-leukocytes are detected.

A few loose cells at bilateral of the wound known as extravasated red blood corpuscles (eRBCs) were detectable while a few blood capillaries i.e. newly formed blood vessels (angiogenesis) were seen in the matrix of the collagen fibers in the sub-mucosa. Some eRBCs are also shown in the matrix of the dermal layer of the control (++) in comparison with experimental (+). Both PMNs and eRBCs had developed around the interrupted hair follicle. At over 30 minutes, congested blood vessels had also developed at the periphery of the wound while the regeneration of the basal epithelial tissues had started to bend over the clotted tissue closing it down in the control skin. PMNs had increased forming a clotting tissue between of bilateral sides of the cut epidermis covering the upper part of the dermis which was confirmed by immunohistochemistry technique (Fig.2B). At this stage, newly formed fibrinous exudates was developed on one side of the injury but had further progressed following increase in

eRBCs. In treated more PMNs arrived and eRBCs population had decreased while both newly and well formed blood vessels increased in comparison with the control injury.

### ***One hour post-injury:***

The eRBCs, PMNs and angiogenesis had increased i.e. newly and well formed congested blood vessels while fibrinous exudates retained over and bilateral of the wound [Fig. 3A-D]. In experimental wound the PMNs decreased, the angiogenesis had increased while fibroblast began to deposit the collagen immature fibres at the wound site as a sign of the end of inflammatory and beginning of proliferation phase. Beginning of the re-epithelialization phase had developed from the wound margin as well as from the skin appendages crawling over the top of the wound bed to provide a cover for the new tissue. Angiogenesis was activated to supply the generating epithelial cells by nutrition leading to proliferation of the basal layer of the epithelium. Some mature hair follicle were covered with the germinating cells as well as with the surrounding adipose tissue and sebaceous gland began to contribute to re-epithelialization. The old keratin had remained on the intact parts of the thin epithelial layer.

### ***Two and four hours wound:***

At 2hrs no clear differences were comparable with 1 hour stage both in control and treated wounds. However, at 8 hrs the control wound an intact epithelium underneath an exhausted epithelial tissue and bilaterally (Fig. 4A). These two different layers revealed different intensity for s-P expression where the damaged epithelium lacks s-P expression in comparison with the intact epithelium and those of the hair follicles (Fig. 4B). The PMNs, mostly lymphocytes and Neutrophils were also detectable underneath the newly formed collagen fibres but were lesser than those of at 1 hour. Similar to the above-mentioned intact epithelial layer, the PMNs, at the immunohistochemical section had expressed s-P reactions. Angiogenesis, as the newly formed blood vessels, had existed at the periphery of the wound close to re-epithelialization zones. New collagen fibers had, at this stage developed, as concave-shaped on the top of the wound site.

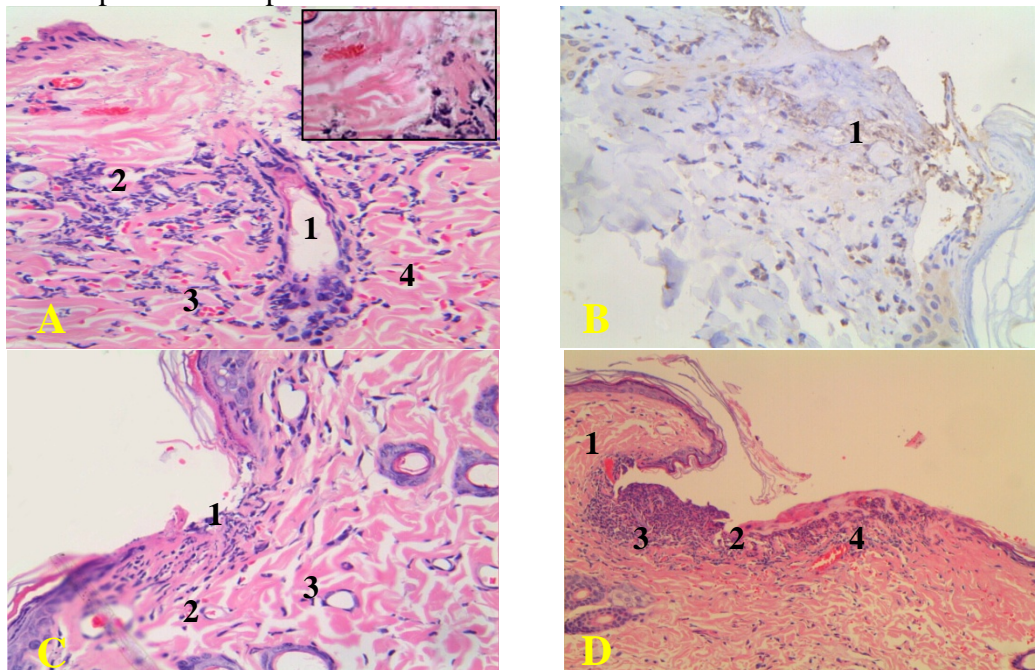

Fig.2: (A) section at 15 minute control wound through the epidermis down to dermis, a hair follicle (1). Note early signs of inflammatory phase i.e. PMNs spreading through the matrix (2); eRBCs (3) at the wound cleavage while newly formed blood vessel are detectable in the dermis (4) [H&E x500]. (B): The expression of s-P in some PMNs (1) (IHC x480); (C): Treated injury where further PMNs (1) have arrived the injury site while eRBCs (2) decreased in comparison with control. Both newly and well formed blood vessels (3) increased in

numbers in comparison with the control injury (H&E x500); and (D): Over 30 min. post-injury time of control shows congested blood vessels (1) at the periphery of the wound. The regeneration started as the basal epithelial tissues has bent over the clotted tissue closing it down. A clear accumulation of the PMNs (2) forming a clotting bilateral of the cut epidermis covering the upper part of the dermis. Newly formed fibrinous exudates (3) and the eRBCs (4) further increased (H&E x250).

### ***Eight Hours post-injury:***

The gap between the two sides of the wound had further closed down in treated wound in comparison with that of control while the collagen fibers had further matured in both wounds than those at earlier stages. In control wounds a few well developed blood vessels were detectable close to the top which could most likely be supplying -as recruited cells- the top of the newly collagen fibers with some epidermal-like cells. The newly formed epidermis appeared thinner, with small flattened cells, than the intact epidermis of cubical cells but with spherical or ovoidal nuclei. The keratin layer had crawled from the top of the intact epidermis to cover the newly formed ones as a barrier from the environment (Fig.5A). A few exterior cells of some blood vessels showed cuboidal cells similar to those of the epidermis with few eRBCs at the periphery of the wound. The PMNs were detectable at the deep dermis in both control and experimental wound as well as some eRBC in control but were significantly ( $p < 0.05$ ) declined in the experimental wounds. However, the well formed blood vessels, the angiogenesis had developed almost in equal amount in both control and experimental wounds.

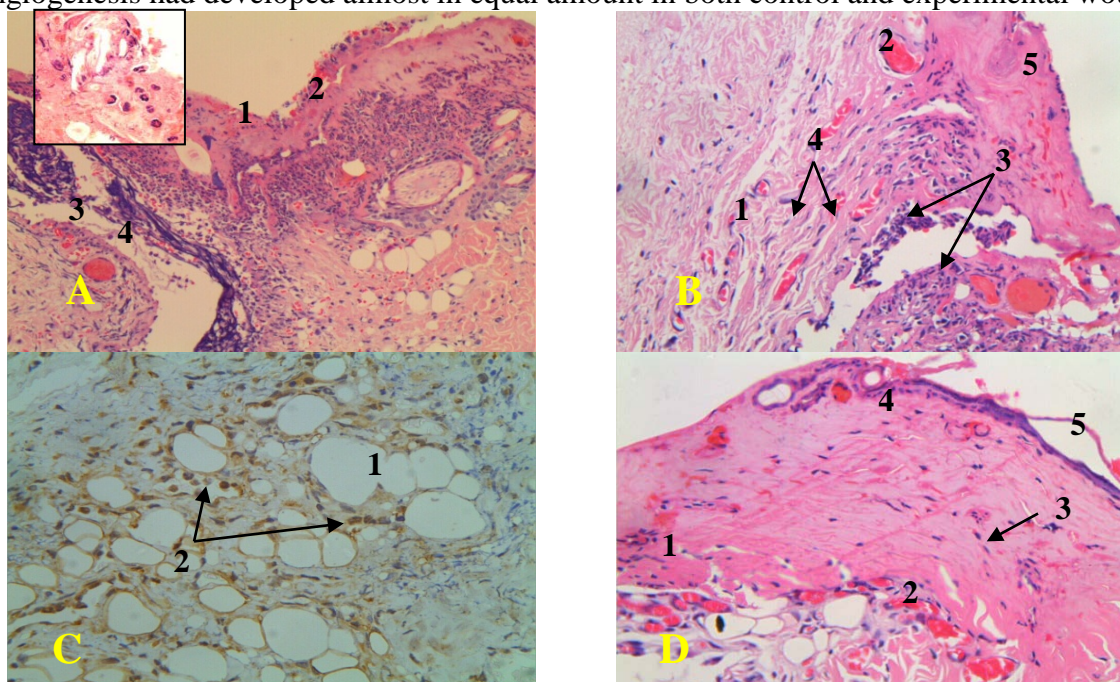
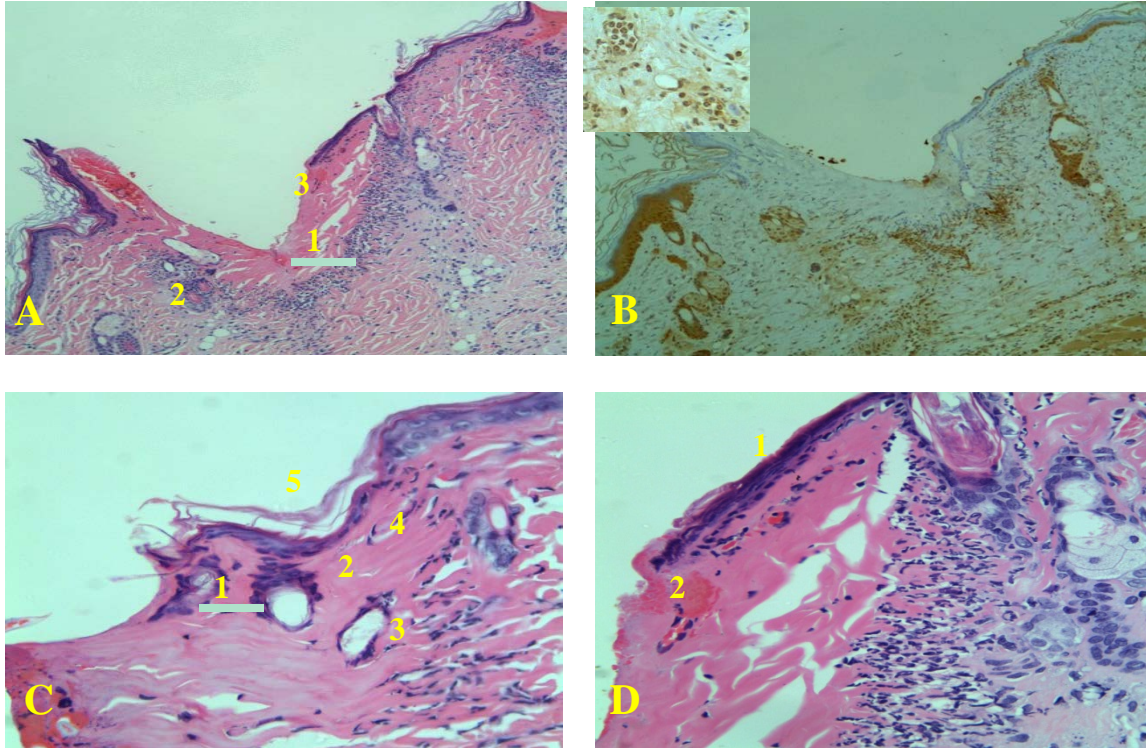

Fig. 3: One hr post injury: (A) Control wound reveals fibrinous exudates (1) between the two sides the wound. The eRBCs increased (2) via spreading within the matrix of the dermis. Congested newly and well formed blood vessels (3&4); PMNs (5) [above right insert] had also increased in comparison with the earlier stages. Adipose cells had developed too in the dermis underneath the PMNs (E&H x250). (B): Control 1hr shows the angiogenesis i.e. newly and well formed blood vessels (1&2 respectively) as well as the PMNs (3). A few fibroblasts at the site of the wound had migrated up to the injury site (4). Fibrinous exudates on the top of the wound (5) (H&E x500). (C): The adipose tissue within the dermis (1); Some PMNs (2) stained with brown (IHC x500). (D) Treated skin shows decrease in PMNs (1) in comparison with control while angiogenesis (2) and fibroblast (3) began to accumulate the collagen immature fiber at the wound site indicating the end of inflammatory phase and beginning of proliferation phase. A beginning of the re-epithelialization phase has just occurred from the wound margin and the skin appendages (4). Old keratin is found on the right side above the thin epithelial layer (5) (H&E x500).

The treated wound had some newly formed epithelium with a top keratin layers crawling over the newly formed collagen fibers with a few eRBCs surrounding the nearly

closing down wound. A few well formed blood vessels were detectable within and on the upper part of the collagen fibers. The PMNs had spread underneath the collagen bed through the well formed collagen fibers almost isolating the top from the bottom (Fig 5B). The eRBCs were spreading within the dermis as well as some newly formed blood vessels (angiogenesis). A few hair follicles were detectable covered with follicular cells as well as and sebaceous gland cells.



(Fig. 4): Two consecutive sections at 4 hours control wound shows the intact (light blue) and an exhausted (dark blue) of the epithelial tissue at both sides of the wound [A] The PMNs (1) are detectable underneath the collagen fibers. Newly formed blood vessels (2) at the periphery of the wound close to re-epithelialization zones. New collagen fibers (3) had developed, as curved-shaped on the top of the wound site (H&E x250). [B] Different affinity to s-P expression where the exhausted epithelium lacks s-P expression in comparison with the intact epithelium (insert) and of hair follicles (IHC x250). Two consecutive sections in high power: [C] Control wounds 4 hrs with a few developed hair follicle (1) as recruiting their outer cells to feed the top of the newly collagen fibers (re-epithelialization). The newly formed epidermis (2) looks much thinner with small flattened cells (3). A few sebaceous gland (4). The keratin layer (5) is crawling from the top of the intact epidermis to cover the newly formed ones. [D]: Details of re-epithelialization (1), newly blood vessels (2), PMNs and sebaceous cells of the hair follicle (H&E x500).

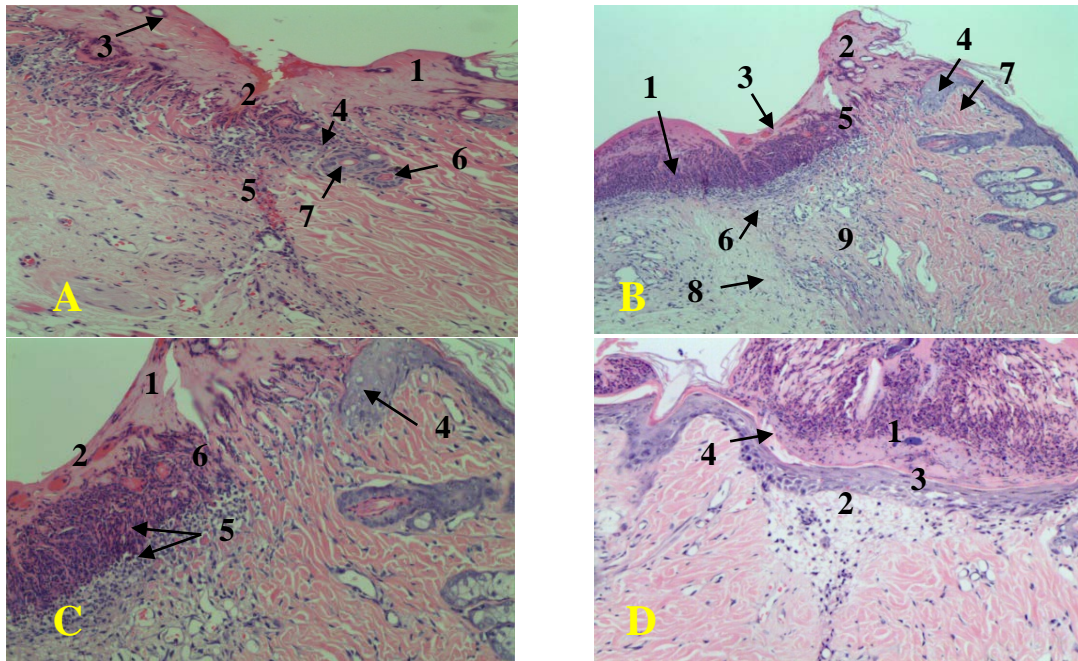

Fig. 5: (A) 8 hrs post-injury treated wound shows the newly formed epithelium with top keratin layer (1). A few eRBCs are still detectable surrounding the nearly closing down wound (2) with a few well formed blood vessels (3). The PMNs are spread underneath the well formed collagen fibers separating top from bottom (4), eRBCs (5), hair follicles (6), sebaceous gland (7); (B): Control wound 24 hrs: fibrinous tissue complex plug (1); re-epithelialized epidermis (2) contained masses of inflammatory tissue PMNs (3); collagen fibres (4) and blood vessels (5) while the two cut ends of the epidermis are apart from each other (6). Two different inflammatory tissues are recognizable in the complex i.e. top darkly stained and bottom lighter stained cells (8) lined up underneath the fibrinous tissue complex alongside the intact epidermis from both sides. A gap separating two dense sub-layer of the dermis which is filled with loose connective tissue (9) contained masses of various sized blood vessels and scattered eRBCs; (C): 24 Control wound shows declined collagen fibers (1) and blood vessels (2). The bilateral of the epidermis are still apart (4). Two different inflammatory tissues are recognizable in the complex i.e. top darkly stained and bottom lighter stained cells (5) with various sizes of blood vessels and scattered eRBCs (6); (D): 24 hrs treated rat skin, the scab of fibrinous tissue complex plug located above the cut with fewer collagen fibers, blood vessels and inflammatory cells. A cushion like-collagen fibres (1) above re-epithelialized epidermis but underneath a fully formed epidermis, a mass of loose connective tissue (2) separate the epidermis from the underneath dermis. The bilateral sides have almost merged forming one piece (3); a fine gap (4) between the fibrinous tissue complex plug and the newly formed epidermis while the complex was still attached to the epidermis in control (H&E x500).

### 24 Hours post-injury:

In control wound, the deep gap did still exist but filled with loose connective tissue contained masses of various sizes of blood vessels and scattered eRBCs. The two sides of the upper dense layer of the dermis were still a part while the scab of fibrinous tissue complex plug located above a part of the re-epithelializing epidermis while the two cut ends of the epidermis were still apart from each other. At this stage the complex was edematous and contained masses of inflammatory tissue PMNs but declining collagen fibres and blood vessels. Two different inflammatory tissues were recognizable in the complex i.e. top darkly stained and bottom lighter stained cells lined up underneath the fibrinous tissue complex alongside the intact epidermis from both sides. The dense sub-layer of the dermis was separated from each other where the gap in between was filled with loose connective tissue contained masses of various sizes of blood vessels as well as scattered eRBCs.

In treated wound, the scab of fibrinous tissue complex plug located above the cut showed degradation phase i.e. less collagen fibers, blood vessels and inflammatory cells. A cushion like-collagen fibers had developed underneath the fibrinous tissue complex plug and above re-epithelialized epidermis. Underneath the fully formed epidermis, a mass of loose connective tissue was developed separating the epidermis from the underneath dermis while



the two sides had almost merged. A fine gap has developed between the fibrinous tissue complex plug and the newly formed epidermis while the complex was still attached to the epidermis in control (Fig. 5).

#### 48 Hours post-injury:

In control wounds, a scab of fibrinous exudate and PMNs had developed over an incomplete and thinner re-epithelialized epidermis while it was almost complete and thicker in treated wounds. The re-epithelialization had characterized by no keratin layer over the newly formed epithelium yet neither of control nor in treated while the extensions of the keratin layer from the intact parts of the epidermis were detectable (Fig. 6). Well formed collagen fibers but with irregular orientation were developed in control while they showed regularity in treated wounds. These collagen fibers had sandwiched by eRBCs from top and a thick layer of PMNs from the bottom. A few PMNs i.e. Neutrophils were still detectable with a few macrophages in control while they less in the treated wounds. Similarly, eRBCs had invaded the incomplete zone of the epilialization with so many PMNs around numerous blood vessels, indicating granulation phase in control yet more in comparison to treated which showed some skin appendages formation. The dense layer of the dermis made up of collagen fibres underneath the wound are still in complete from the middle with many PMNs cells. Adipose tissues are filled at the loose (reticulate) layer of the dermis making a bed-like cushion.

In treated wound, the healing process had advanced i.e. a complete re-epitheilization, an almost formed scab, from fibrin-fibronectin clot. The latter hold the wound close has reduced in size with a concave shape tissue mass made of fibrobalsts and inflammatory cells (PMNs) including macrophages, Neutrophils, lymphocytes. The angiogenesis was still predominant amongst the scab tissue. The keratin had crawled from both sides underneath the scab from the top while the latter had further separated from the newly formed epithelium leaving small gaps starting from the sides to the middle of the bottom. Notably, the skin appendages had re-formed i.e. hair follicles, sebaceous glands, with no inflammatory cells underneath the newly formed epithelium. In addition bilateral dense collagen fibres had already connected in the middle as a complete piece of tissue in comparison with the control wound which was not (Fig. 6).

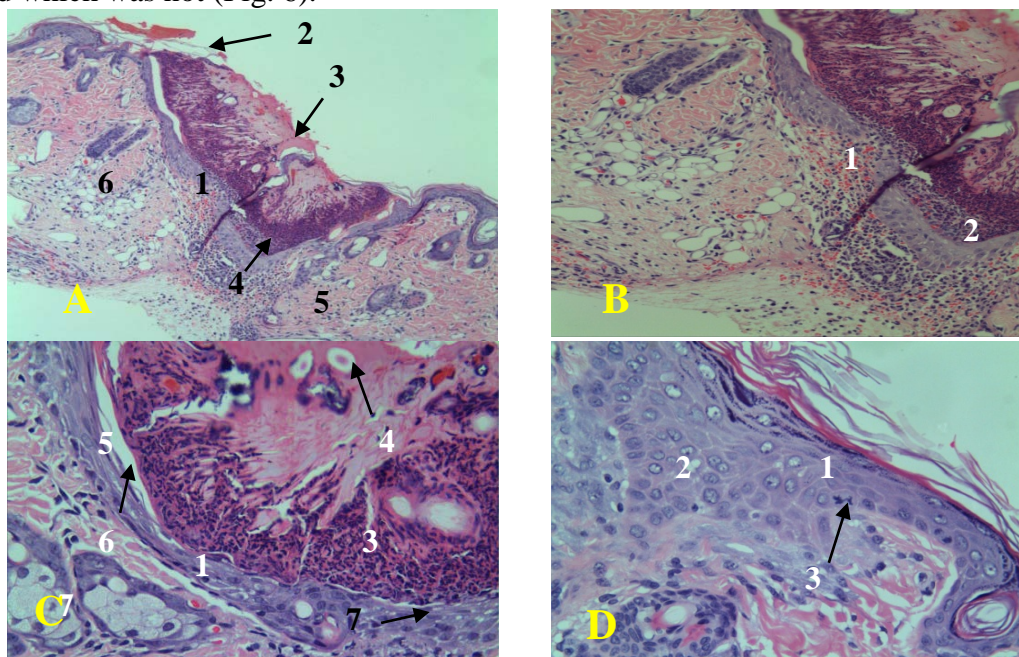

Fig. 6: Sections of control wound 48hrs post-injury [A]: a scab of fibrinous exudates and PMNs had developed over an incomplete-epithelialized epidermis (1) and the wound gap (2), is still apart between. Top irregularly oriented collagen fibers, is sandwiched by eRBCs (3) from top and a thick layer of PMNs from the bottom (4).

Clusters of eRBCs are invading the incomplete epithelialization (1) with many PMNs around, a dense collagen fibers is incomplete from the middle (5) with many PMNs cells. Adipose tissue are filled at the loose (reticulate) layer of the dermis (6) making a bed-like cushion (H&E x250). [B] Control wound 48 hrs with a scab of fibrinous exudates and PMNs over an incomplete-epithelialized epidermis (1) from top and a thick layer of PMNs at bottom (2) (H&E x500). [C]: Treated wound 48 hrs shows a complete re-epithelialized layer (1), the scab (2) which is mostly formed from fibrin-fibronectin clot has been reduced in size with a concave shape tissue mass made of fibroblasts and inflammatory cells including (PMNs) Neutrophils, macrophages (3) and the angiogenesis (4). The keratin crawled from top of both sides underneath the scab (5) but further separated from the newly formed epithelium leaving small gaps (6) starting from the sides to the middle of the bottom. Skin appendages had re-formed i.e. hair follicles, sebaceous glands (8), with no inflammatory cells underneath the newly formed epithelium. [D]: The bilateral dense collagen fibers already connected to each other as a complete piece of tissue in comparison with the control wound which was not. A newly formed epithelium (2) with still dividing cells (3) (H&E x250).

#### **4 Days post-injury:**

The control wound had a complete re-epithelialization at the incision spot where keratin layer had covered the whole area. However, a lump of re-epithelialized layer (a thicker layer of almost 8 rows of cells) was in developing stage at the spot of injury down alongside the masses of inflammatory cells i.e. PMNs cells. Some basal cells of the re-epithelialized layer showed division activities. No newly formed collagen fibres are detectable at this stage while the inflammatory cells had contained a few WBCs. In experimental wounds, no clear histological differences were comparable to normal tissues as a complete recovery of the healing has been established as if normal.

**8 Days post-injury:** No clear histological differences were detectable neither in both control and in experimental wounds nor any scars were recognizable from the wounds at this stage.

#### **3.3 Angiogenesis throughout the wound injury:**

The angiogenesis activity was counted to correlate with the time of injury in both control and experimental wounds in rat skin as number per high power field of view (x400). The numbers of blood vessels have significantly ( $p < 0.003$ ) ascended as early as 15 minutes post-injury and reached peak at 1-2 hours in comparison with control before declining at 4 hours. Then it significantly ( $p < 0.01$ ) picked up ascending again at 8 hours recording a significant differences ( $p < 0.01$ ) at 24 hours in comparison with the control [Fig. 7].

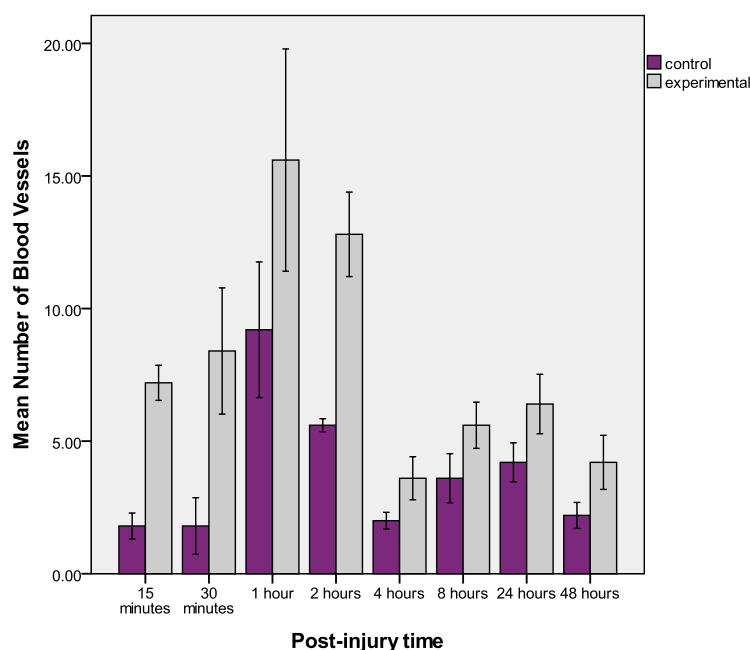

(Fig. 7): Angiogenesis in both control and experimental wounds in rat skin counted as number per field of view in a series of 5 consecutive sections using Olympus microscope. Note numbers of blood vessels significantly ( $p < 0.003$ ) ascended starting from 15 min. post-injury and reached peak at 1 hour in comparison with control before declining after 2 hours. Then it relatively picked up again starting from 8 hours recorded significant difference ( $p < 0.01$ ) at 24 hours in comparison with the control. ANOVA biostatistics was applied to calculate the differences.

### 3.4 Comparison of Healing:

A comparison between the healing processing times of human with those of rat skin had indicated that the hemostasis in both human and rats do start simultaneously and immediately after the injury. The inflammation phase in human does start between the 1st and 2nd day and continued upto 3rd and 4th day while in control rats this stage started within 15 minutes and continued upto 4 hours. However, in treated rats, the inflammatory phase started simultaneously but lasted shorter than those of control ( $< 1$  hour). The proliferation phase in human begins within hours from injury impact and lasts 2-4 weeks. In Control rats this phase began at the first 4 hours post-injury and lasts almost 4 days; while in treated rats it began within an hour and lasts less than 4 days. Finally, the remodeling phase in human may last weeks to months depending upon the size of the wound and other common factors i.e. depth, location etc. In control rat, this phase ended up within 8 days while in treated rats it was completed with less than 4 days (Figure 8).

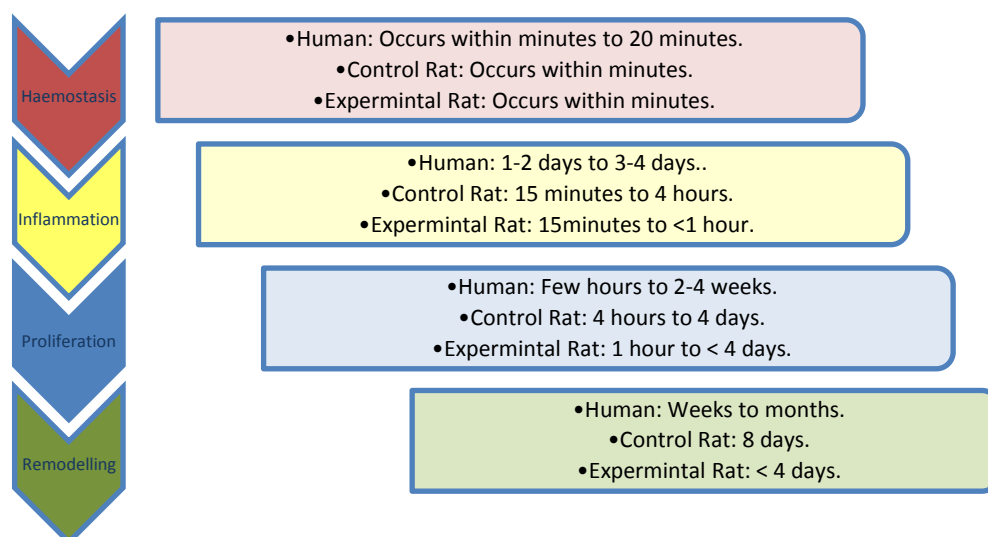

(Fig.8): Schematic diagram to compare duration of the healing phase between human and in both control and treated rats.

## 4. Discussion:

### 4.1 Macroscopic Observations:

All experimental rats were same gender, age and from same batch of healthy litters and the whole bodies were checked out intact and healthy of any unexpected injury. The precautions taken throughout this research had guaranteed an almost early and subsequent unbiased histological result. Intention has been made to investigate the healing potency of a single topical application of the optimal dose (0.3 ng/mL) of synthetic b-FGF being already studied in previous work (Bazzaz *et al.*, 2012). Experiments have also been carried out in duplicate using the same optimal dose to eliminate any biased interpretation (Gundersen and Jensen, 1985; Gardi, *et al.*, 2006). The two injuries made alongside each other of the same rat provided a close monitoring facilities to follow the healing process towards eliminating any misinterpretation of individual animal differences.

Skin healing, generally, is a complex and an intricate process as so many factors would implicate in cure of an injury. Without any treatment the skin injury could repair itself

up after impact according to recent model of Nguyen *et al.*, (2009). The occurrence of tiny bleeding and its quick stoppage in both wounds post-incision could refer to the effect of the salty component of the phosphate buffer saline which might have acted as an antiseptic/antibiotic (Hayley, 2011). This is evident from the fact that hypertonic solutions will absorb the water from surroundings and leave the germs to shrivel and die. Mammals e.g. dogs, cats, squirrels etc.. do use their saliva to clean their wounds which contain histamine, a small protein in saliva has previously been believed to kill bacteria was responsible for the healing wounds and to provide antiseptic agents to protect the wound from any microbial infection. It also increases inflammation and activity of the enzyme elastase, which destroys tissue debris (JADA, 2001). Despite the fact that licking the wounds by pets carries a risk of infection (Weil *et al.*, 2002); however saliva may also contain Nitric oxide (Benjamin *et al.*, 1997), peroxidase in human (Ihalin *et al.*, 2006), epidermal growth factors (EGF) which promotes the injury healing (Jahovic *et al.*, 2004); does also stimulate healing of chronic wounds by EGF (Nanney, 1990; Brown *et al.*, 1991) and can enhance wound healing by topical treatment (Niall *et al.*, 1982; Brown *et al.*, 1989). Choosing the scalp area between the two ears for a pair of incisions would have relatively eliminated the direct role of saliva of the rats to reach the wounds and any consequent misinterpretation of the results.

Macroscopic observations revealed clean wounds with less or a very small clot in treated wounds in comparison with those of the control. Such a observation could indicate -to certain extend- the antiseptic contents, sterility and the potency of the synthesized b-FGF.

Anatomical observations have also showed presence of yellowish capping tissue at the top of the treated wounds (fibrinous exudates). This might indicate more plasma and perhaps more immune cells being driven to the injury sites in the treated wounds in comparison with the reddish black clots observed at the control wounds. The presence of a very little or no clot in treated rats might indicate the potency of the b-FGF to minimize bleeding of the wounds by accelerating the clotting process via catalyzing the formation of fibrin to seal the cut ends of the bled capillaries. It could also interpret declining in temperature of the wound after raise due to development of edema by angiogenesis. However, this issue needs further speculation to prove such assumption. A remarkable reduction in healing time started at almost 8 hrs post-injury leading to a quick closure, contraction of both ends and narrowing of the width of the wound in treated wound in comparison with control. It is likely that application of synthetic b-FGF had contributed to promote contraction of the wound leading to 50% reduction in healing time. The contraction of the wounds has been related to a specialized fibroblasts are responsible for wound contraction (Brown *et al.*, 1989; Heiko *et al.* 2009).

Such contracting ability might also present a possible capability of the b-FGF to compensate the stitches which some small or moderate sized wounds may need. Such a conclusion may not be a standard scenario to every skin injury as each wound has its specific characteristics which may vary from this model. These morphological improvements in healing of small wounds in rats had encouraged us to pre-conclude its likelihood potency to act as catalytic and septic additives in some topically used medicines for external wounds i.e. creams and septic solutions like iodine.

#### **4.2 Histological observations:**

Histological data had run parallel to the anatomical observations to investigate the details of the tissue behavior and the growth pattern for correlation the healing process. The incision showed the distance of the two sides of the injury involving epidermis and underneath collagen fibres are set apart confirms the full depth of the incision being made in our rat models through this project. At any skin injury cases, a set of complex biochemical, cascading molecular and cellular leading to hemostasis and formation of an early, makeshift extracellular matrix (ECM), provide structural support for cellular attachment and subsequent cellular proliferation. Such events could add different interpretation scenario for any injury.

The 3-4 overlapping sequential phases of wound healing process i.e hemostasis, inflammatory, proliferative and remodeling (Stadlmann *et al*, 1998) found in rats are comparable to those of human. Such an overlapping phenomenon would obscure the many elements of wound healing to be clearly delineated offering the scientist a chance to assume more than a single interpretation.

Bleeding takes place immediately after the incision depending on several factors, depth, size location etc... which include blood plasma, RBCs, platelets and Leucocytes (MPNs). Platelets, the cells present in the highest numbers shortly after a wound occurs, release extra cellular matrix (ECM) proteins and cytokines, including GFs (Rosenberg and de la Torre, 2006). While the function of GFs is to stimulate cells to speed their rate of division platelets, however, release other pro-inflammatory factors like serotonin, bradykinin, prostaglandins, prostacyclins, thromboxane, and histamine, which altogether serve a number of purposes, involving cell proliferation, migration to the area and to cause blood vessels to become dilated and porous (Stadlmann *et al*, 1998). In human, the tissue disruption, platelets release coagulation factors which enhance the released cytokines to initiate the healing process. Within the first day the Neutrophils attach to surrounding vessel walls prior moving through the vessel walls to migrate to the wound site. Immunohistochemical sections had shown many Neutrophils, Monocytes and Lymphocytes in the injury site which all indicate the activation of immune system. The WBCs had immediately invaded the injury area post-injury indicating occurrence of the above process in rats too.

The bleeding intervals in rats lasted almost 3-4 minutes similar to those of human beings i.e. blood capillaries and infiltration of PMNs to the wound site spreading through the matrix in both control and treated wounds. The latter may indicate an invasion and aggregation of the platelets (thrombocytes) at the injury site to form a fibrin clot remarking the early phase of hemostasis prior to the inflammatory. This might indicate the onset of an early signs of inflammatory phase in the rat model. The less PMNs found in treated wound in comparison with those of control had been confirmed by immunohistochemically expressing substance-P (s-P) cells in some leukocytes. Such observation may indicate the contribution of b-FGF in activating the immune system in the treated rat wounds to reduce healing time.

At bleeding, the blood comes in contact with collagen, triggering blood platelets to secrete inflammatory factors (Rosenberg and de la Torre 2006). While platelets also express glycoproteins on their cell membranes to allow them stick to one another and to aggregate, forming a mass (Midwood, *et al* 2004). This process takes place in every single incised wound following bleeding as Fibrin and fibronectin cross-link together and form a plug that traps proteins and particles and prevents further blood loss (Sandeman *et al*, 2000) which also is the main structural support for the wound until collagen is deposited (Midwood, *et al* 2004). This is concomitant with contents of the fibrinous exudates formed over the injury spot in the first hour post-injury. Migratory cells and newly formed epithelial cells had used fibrinous exudates plug as a matrix to crawl across as seen after 24 hours post-injury. Simultaneously, platelets adhere to the plug and secrete natural GF to accelerate growth pattern and rate. In the present study, b-FGF was a *bonus synthetic factor* which promoted cell division through the process of re-epithelialization and formation of collagen fibers. In addition, the clusters of eRBCs as well as the angiogenesis within both the fibrinous exudates and the underneath dermis have all contributed to speed up cell division and collagen deposition. At day 4 the clot was completely lysed, replaced with granulation tissue and later with collagen. This is unsurprising due to the small size of the wound being incised in this project.

The angiogenesis activity showed significant significantly ascending as early as 15 minutes post-injury reaching a peak at 1-2 hours in comparison with those of control is correlatable to the positive multifunctional effects of the b-FGF similar to EGF and PDGF.

Scars were absolutely absent from the wound at day 8 and no remodeling was seen at the wounds. This is not surprising because the healing process was a small in size and no craft or full regeneration was due.

Scientist had used various proteins and GFs to promote injury healing in aged rats i.e. sensory peptides as Neuromodulators (Khalil and Helme 1995) and hematopoietic growth factor erythropoietin (EPO) was treated either with repetitively low dose or high doses used on hairless mice lead to acceleration of wound epithelialization, reduced wound cellularity, and induced maturation of newly formed microvascular networks (Heiko *et al.*, 2009).

The present work of a single topical application of a lowest dose (0.3 ng/mL) of synthetic b-FGF initiated highest cell division *in vitro* (Bukhari, 2012; Bazzaz *et al.*, 2012). The same dose used *in vivo* had a general promotion effects revealed in morphological, histological and immunohistochemical experiments in reducing healing time to almost 50%. Perhaps, the promoting effects of a topical application of a multiple dose of this synthetic b-FGF could yield a better outcome. Application, of this dose together with natural standard products (NSP) may even produce a robust healing task for surgeons who may eliminate stitches from small skin injuries due to potential contracting effects of the b-FGF being found in this study.

The comparison between the healing processing times of human with those of rat skin had confirmed the simultaneous time onset of the hemostasis phase. This is not a surprising results as the hemostasis does onset immediately soon after each injury. The inflammation phase in human does start in later time than those of rats which started within 15 minutes in both control and treated but was completed in treated rats earlier (<1 hour) while at almost 3 to 4 in control. This phase has been reduced in treated rats due to the activation of the immune system in the skin to accelerate the completion of this phase. The proliferation phase in human begins within hours from injury impact and lasts 2-4 weeks, depending upon the size of the injury i.e. in control rats this phase began at the first 4 hours post-injury and lasts almost 4 days; while in treated it begins within an hour and lasts less than 4 days. This might be to induction of angiogenesis to provide enough nutrition to the generating tissues. Finally, the remodeling phase in human may last much longer than those of small animals depending to many common factors, while it was much shorter in control rat (8 days); however in treated rats it lasts less than 4 days.

Despite the above argument, logic or a feasible rapprochement between the healing process times of rat skin with those of human was incomparable due to the involvement of so many factors in determining the specificity of each wound in both. To confirm these results, human volunteers, using the same scenario of rat model, may be feasible to for comparative studies.

## 5. Conclusion

The histological results indicated multifunctional potency of b-FGF similar to those EGF and PDGF and provided evidences of credence *in vivo* therapeutic medicine on industrial scales.

## References:

- Bayram, Y; Deveci, M; Imirzalioglu, N; Soysal, Y and Sengezer, M (2005) "The cell based dressing with living allogenic keratinocytes in the treatment of foot ulcers: a case study". *British journal of plastic surgery* 58(7): 988–96.
- Bazzaz, AA; Bukhari, FO; Muhammad, AI and Chelebi, NA (2012). *In vitro* assessment of growth promoting activity of a synthetic basic fibroblast growth factor (b-FGF) using Rama-27 cell line. *JSTU*; 6: 28-33.

- Bazzaz AA and Chelebi, NA (1998) "Ultrastructural features of seven types of dorsal root ganglia (DRG) neurones in the Mongolian gerbil *Meriones unguiculatus*". *5th Sci Conf; SRC; Proc*: 358-373.
- Benjamin N, Pattullo S, Weller R, Smith L and Ormerod A (1997) "Wound licking and nitric oxide". *Lancet* 349(9067): 1776. PMID 9193412. Also available at: [http://www.thelancet.com/journals/lancet/article/PIIS0140-6736\(05\)63002-4/fulltext](http://www.thelancet.com/journals/lancet/article/PIIS0140-6736(05)63002-4/fulltext).
- Bond, JE; Kokosis, G; Ren, L; Selim, MA; Bergeron, A and Levinson, H (2011) Wound contraction is attenuated by fasudil inhibition of Rho-associated kinase. *Plast Reconstr Surg*. 128(5): 438e-450e.
- Brown, GL; Curtsinger, L; Jurkiewicz, MJ; Nahai and Schultz, G (1991) Stimulation of Healing of Chronic wounds by epidermal Growth factors. *Plastic d reconstructive surgery*; 88(2): 189-194. *American Society of Plastic Surgeon*. Also available at: <http://journals.Lww.com/plasreconsurgery/Abstract/1991/08000>.
- Brown, GL; Nanney, LB; Griffen, J; Cramer, AB; Yancey, JM; Curtsinger LJ; Holtzin, L; Schultz, GS; Jurkiewicz, MJ; Lynch and JB (1989) Enhanced of wound healing by topical treatment with epidermal growth factors; *New England J Medicine*, 321: 76-79.
- Bukhari, F O (2012). The potency of some synthesized peptides as growth factor in skin healing of rats. MSc Thesis, taibah University, KSA.
- de la Torre, J and Sholar A (2006) Wound healing: Chronic wounds. Emedicine.com.
- Desmouliere, A; Chaponnier, C and Gabbiani, G (2005) "Tissue repair, contraction, and the myofibroblast". *Wound Repair and Regeneration* 3 (1): 7-12.
- Falanga, V (2005) Wound healing and its impairment in the diabetic foot. *Lancet* 366: 1736-1743
- Finklestein, SP and Plomaritoglou, A (2001) "Growth factors". In Miller L.P., Hayes RL, eds. Co-edited by Newcomb JK. *Head Trauma: Basic, Preclinical, and Clinical Directions*. New York: Wiley. 165-187.
- Gardi, GE; Nyengaard, JR and Gundersen, HGJ (2006) Using biased image analysis for improving unbiased stereological number estimation - a pilot simulation study of the smooth fractionator, *J. Microsc.* 222: 242-250.
- Gundersen, HJG and Jensen, EP (1985) Sterological estimation of the volume-weighted mean volume of arbitrary particles observed on random sections, *J Microsc.* 138: 127-142.
- Hayley, E (2011) Why could a salt solution be used as an antiseptic for a cut? Also available at: <http://answers.yahoo.com/question/index?qid=20081115142429AAm2g8Z>
- Heiko, S; Krueger, C; Schultz, T; Menger, MD; Schmittz, F and Vollmar, B (2009) Effects of erythropoietin in skin wound healing are dose related. *The FASEB Journal*; 23: 3049-3058.
- Ihalin, R; Loimaranta, V and Tenovuo, J (2006) "Origin, structure, and biological activities of peroxidases in human saliva". *Arch Biochem Biophys*, 445(2): 261-8.
- Jahovic, N; Güzel, E; Arbak, S and Yeğen, BC (2004) "The healing-promoting effect of saliva on skin burn is mediated by epidermal growth factor (EGF): role of the neutrophils". *Burns*, 30(6): 531-8.
- Khalil, Z and Helme, R (1995) Sensory Peptides as Neuromodulators of Wound Healing in aged rats; *J Gerontology*; 51: B354-B361.
- MacKay, D and Miller, AL (2003) Nutritional Support for Wound Healing. *Alternative Medicine Review*, (8) 4:359.
- Martin, P (2001) Wound Healing Lessons from embryos. *British Society for Cell Biology (BSCB)*.
- Martin, P and Leibovich, SJ (2005) "Inflammatory cells during wound repair: the good, the bad and the ugly". *Trends in Cell Biology* 15(11): 599-607.
- Midwood, KS; Williams, LV and Schwarzbauer, JE (2004) "Tissue repair and the dynamics of the extracellular matrix". *The International Journal of Biochemistry & Cell Biology* 36(6): 1031-1037.

- Mirastschijski, U; haaksma, CJ; Tomasek, JJ and Agren, MS (2004). Matrix metalloproteinase inhibitor GM 6001 attenuates keratinocyte migration, contraction and myofibroblast formation in skin wounds. *Experimental Cell Research* 299(2): 465-475.
- Muller, MJ; Hollyoak, MA; Moaveni, Z; La, T; Brown, H; Herndon, DN and Heggers, JP (2003). "Retardation of wound healing by silver sulfadiazine is reversed by *Aloe vera* and nystatin". *Burns* 29(8): 834–836.
- Naill, MBS; Graeme, B; Ryan, MD; Bernard C and Mc O'Brien (1982). The effects of epidermal growth factor on wound healing in mice; *J. Surgical Research*; 33: 164-169.
- Nanney, L B (1990) Epidermal effects of Epidermal growth factors during wound healing. *J Investigative Dermatology*; 94: 624-629.
- Nguyen, DT; Orgill, DP and Murphy, GF (2009) Chapter 4: The Pathophysiologic Basis for Wound Healing and Cutaneous Regeneration. *Biomaterials For Treating Skin Loss*. Woodhead Publishing (UK/Europe) & CRC Press (US), Cambridge/Boca Raton, p. 25-57.
- O'Leary, R; Wood, EJ and Guillou, PJ (2002) "Pathological scarring: strategic interventions. *The European journal of surgery = Acta chirurgica* 168(10): 523–34. PMID 12666691.
- Quinn, JV (1998) *Tissue Adhesives in Wound Care*. Hamilton, Ont. B.C. Decker, Inc. Electronic book.
- Romo, T and Pearson, JM (2005) Wound Healing, Skin. Emedicine.com. Accessed December 27, 2006.
- Rosenberg, L and de la Torre, J (2006) Wound Healing, Growth Factors. Emedicine.com.
- Sandeman, SR; Allen, MC; Liu, C; Faragher, RGA and Lloyd, AW (2000). Human keratocyte migration into collagen gels declines with in vitro ageing. *Mechanism of Ageing and Development*, 119(3): 149-157.
- Sørensen, OE; Thapa, DR; Roupé, KM; Valore, EV; Sjöbring, U; Roberts, AA; Schmidtchen, A and Ganz, T (2006) "Injury-induced innate immune response in human skin mediated by transactivation of the epidermal growth factor receptor.". *The Journal of clinical investigation* 116(7): 1878–85.  
<http://www.pubmedcentral.nih.gov/articlerender.fcgi?tool=pmcentrez&artid=1479426>
- Stadelmann, WK; Digenis, AG and Tobin, GR (1998) "Physiology and healing dynamics of chronic cutaneous wounds.". *American journal of surgery* 176 (2A Suppl): 26S–38S.
- Weil, HP; Fischer-Brügge, U and Koch, P (2002) "Potential hazard of wound licking". *N. Engl. J. Med.* 346(17): 1336.
- Yip, J and Chahl, LA (April 2001) "Localization of NK1 and NK3 receptors in guinea-pig brain". *Regulatory peptides* 98(1-2): 55–62.



# GAMMA IRRADIATION PRESERVATION OF CHESTNUT FRUITS: EFFECTS ON COLOR AND TEXTURE

***Amilcar L. Antonio, MSc***

Polytechnic Institute of Braganca, CIMO/School of Agriculture, Portugal  
IST/ITN Nuclear and Technological Institute, Portugal  
University of Salamanca, Department of Fundamental Physics, Spain

***Angela Fernandes, MSc***

***Albino Bento, PhD***

Polytechnic Institute of Bragança, CIMO/School of Agriculture, Portugal

***Armando Ferreira, PhD***

***M. Joao Trigo, PhD***

National Institute of Biological Resources, Portugal

***M. Luisa Botelho, PhD***

IST/ITN Nuclear and Technological Institute, Portugal

***Begona Quintana, PhD***

University of Salamanca, Department of Fundamental Physics, Spain

***Elsa Ramalhosa, PhD***

Polytechnic Institute of Braganca, CIMO/School of Agriculture, Portugal

---

## Abstract

Chestnuts are a seasonal fruit that must be postharvest treated to meet food safety regulations. In this study the effect of gamma irradiation on color and texture of chestnut fruits from a European variety (*Castanea sativa* Miller) was reported. The fruits were subjected to gamma irradiation doses of 0.5, 3 and 6 kGy, with color and texture properties analyzed along a typical commercial period for this fruit after postharvest treatment, at 0, 15 and 30 days of storage. For *L* and *b* color parameters, significant differences ( $p < 0.05$ ) were observed with irradiation dose (ID) only for higher doses of 3 kGy and 6 kGy. Along storage time (ST) significant differences ( $p < 0.05$ ) were observed for fruits interior (half-cutted) after 15 days of storage. Regarding texture, differences on fruits were only detected for chestnuts irradiated with 6 kGy. With this study we can identify the maximum acceptable dose for irradiation processing of these fruits, concluding that gamma irradiation could be a promising alternative technology for postharvest disinfestation of European chestnuts varieties, to meet food safety international trade regulations, not affecting significantly two important parameters for the consumer, the color and texture.

---

**Keywords:** Chestnut fruits, food irradiation, color, texture

## Introduction

Chestnut fruits world production is about 1.1 million tons, being Portugal the second producer of European varieties (*Castanea sativa* Miller) with about 30 000 ton. From these about 10 000 ton are for exportation, representing an income of 13 MEuros (FAOSTAT, 2010; INE 2010). Chestnuts are a seasonal fruit that must be postharvest treated to meet food safety regulations. Traditionally, the fresh fruits were postharvest fumigated with methyl bromide to meet the international phytosanitary regulations for pest quarantine. However, its use has recently been prohibited in Europe, in March 2010 (EU, 2008), following an

international regulation, the Montreal Protocol (UNEP, 2000), existing no or few alternatives to the producers and agro-industry that process this fruit. In this context, irradiation may be a feasible alternative if the food product meets the needed quality parameters after processing.

Food irradiation is a well established technology, approved by international organizations of food (FAO – Food and Agriculture Organization) and health (WHO – World Health Organization), regulated in European Union by the Directive 1999/2/EC (EU, 1999). Gamma irradiation has been studied as preservation technology for many years and it is now approved for several food products (EU, 2009) and irradiation doses till 10 kGy presents no hazard for the consumer (FAO/IAEA/WHO, 1981). A recent report from E.U. Scientific Commission recommends that each irradiated food requires an individual evaluation, as processing and storage generalizations are not possible (EC, 2003). Generally, irradiation doses are classified in three groups: for insects' disinfestation, lower than 1 kGy; for decontamination and reduction of pathogenic microorganisms, 1 to 10 kGy; and for sterilization, higher than 10 kGy (Molins, 2001). In fruits, gamma irradiation may change some sensorial parameters, namely color or texture, which can cause the product rejection by the consumer (Pérez *et al.*, 2009).

Studies in gamma irradiated chestnuts on color parameters have been done mainly in Asian varieties, but not for texture (Antonio *et al.*, 2012). However, Asian and European varieties are different, namely in size and flavor (Vossen, 2000). As far as we know, this is the first time that the influence of gamma irradiation on color and texture of European varieties is reported.

## Materials and methods

### *Samples*

Chestnut fruits (*Castanea sativa* Miller) samples, harvested in November 2010, were obtained from an industrial unit with different European varieties and ready for marketing. The fruits were divided in four groups to be exposed to the radiation doses of 0, 0.5, 3 and 6 kGy - being 0 kGy the non-irradiated, the control sample. Each group was dimensioned for the experimental chamber, containing 35 chestnuts (approximately 350 g), with 2 batches for each dose. After irradiation, the samples were stored at 4 °C, being the color and texture monitored during a typical commercial period from postharvest treatment to marketing, at 0, 15 and 30 days.

### *Irradiation*

The irradiations were performed in a Co-60 experimental equipment, with a total activity of 267 TBq (7.2 kCi) in November 2010 (Gravatom, model Precisa 22, from Graviner Manufacturing Company Ltd., U.K.), as described in a previous study (Antonio *et al.*, 2011). To estimate the dose for the irradiation positions, a dosimetric characterization of the gamma chamber was done using a sensitive radiation chemical solution, Fricke dosimeter, based on an oxidation process of ferrous ions to ferric ions in acidic aqueous solution by ionizing radiation. After irradiation, the dose and dose rate was estimated following the standard (ASTM E1026, 1992) and the procedure described by Antonio *et al.* (2011). During the irradiation process, four routine dosimeters (Amber Perspex batch V, from Harwell co., U.K.) sensitive in the 1 to 30 kGy range, were used to monitor the process for the higher doses (3 and 6 kGy). For the lower dose (0.5 kGy) it was used the known dose rate, previously obtained with the standard Fricke dosimeter. The samples were rotated up side down (180°) at half of the time, to increase the dose uniformity. The Amber Perspex dosimeters were read in a UV-VIS spectrophotometer (Shimadzu mini UV 1240) at 603 nm, two readings for each, to estimate the dose according to a previous calibration curve.

### *Axial dimensions*

The axial dimensions of the fruits were determined measuring the length (L), width (W) and thickness (T) of three chestnut fruits from each batch at each time point, using a digital

calliper with precision of 0.01 mm. The arithmetic and geometric diameters, as well as the sphericity, were calculated using the equations (1), (2) and (3) (Mohsenin, 1978).

$$\text{Arithmetic diameter: } D_a = (L + W + T)/3 \quad (1)$$

$$\text{Geometric diameter } D_g = (L \times W \times T)^{1/3} \quad (2)$$

$$\text{Sphericity } \Phi = (L \times W \times T)^{1/3} / (\max [L, W, T]) \quad (3)$$

#### *Fruit's density*

To calculate the fruit density five chestnut fruits randomly chosen from each irradiation dose were weighted on an electronic balance to an accuracy of 0.0001 g (Balance ABS 220-4, KERN & Sonh GmbH, Germany). The displaced volume of each chestnut fruit in toluene was determined following the procedure described by Yildiz et al. (2009). The density was calculated by the ratio of mass by the volume.

#### *Color*

For color, Hunter parameters ( $L$ ,  $a$ ,  $b$ ) were measured using a colorimeter (Konica Minolta model CR400, Japan), calibrated with a white tile, using C illuminant and diaphragm aperture of 8 mm. The measurements were made on the fruit after hand peeling (whole peeled fruit) and after cutting the fruits by the middle (fruits interior). The color of chestnuts was measured in three different points, for each dose and at each time point.

#### *Texture Analysis*

For texture analysis it was used a TA-Hdi Texture Analyser (Stable Microsystems, UK) in compression mode, with a probe of 2 mm diameter (SMS P/2), load cell of 50 kg and test velocity of 0.83 mm s<sup>-1</sup>. The distance for the probe was set at 22 mm to guarantee that it crossed completely the fruits. A sub-sample of chestnuts, randomly chosen, of each dose was taken at 0, 15 and 30 storage days. After hand peeling, the fruits texture was determined for each, registering the maximum value for the force of penetration.

#### *Statistical analysis*

All results were analyzed using the “*Mathematica*” software (version 8, Wolfram Research Inc., USA). A 2-way ANOVA, with “irradiation dose” (ID) and “storage time” (ST) as the main factors, followed by a *Tukey* means comparison at a 5% significant level was performed. When IDxST interaction was detected a means comparison was performed for irradiated and stored samples with non-irradiated and non-stored samples, for each single factor (Montgomery, 2001).

## Results

### *Irradiation doses*

The estimated value for the dose rate was 0.80 kGy h<sup>-1</sup> with an average uniformity dose ratio,  $D_{\max}/D_{\min}$ , of 1.12, which was in conformity with the good practices for food irradiation (EU, 1999). After irradiation processing and dosimeters reading, the estimated doses were  $0.50 \pm 0.10$ ,  $2.92 \pm 0.09$ ,  $5.62 \pm 0.93$  kGy, for the irradiated samples. For simplicity, 0.5, 3 and 6 kGy is used along the text.

### *Physical characteristics*

The axial dimensions, arithmetic and geometric diameters, and sphericity as well the mass and density of irradiated chestnut fruits, are presented in Table 1.

**Table 1.** Physical characteristics of chestnut fruits (*Castanea sativa* Mill.)

m (g)	W (cm)	L (cm)	T (cm)
$9.28 \pm 1.30$	$2.82 \pm 0.10$	$3.17 \pm 0.21$	$1.76 \pm 0.25$
$\rho$ (g cm <sup>-3</sup> )	$D_a$ (cm)	$D_g$ (cm)	$\Phi$
$1.14 \pm 0.13$	$2.58 \pm 0.19$	$2.50 \pm 0.13$	$0.79 \pm 0.05$

Mass (m), width (W), length (L), thickness (T), density ( $\rho$ ), arithmetic ( $D_a$ ) and geometric diameters ( $D_g$ ), sphericity ( $\Phi$ ).

The results are expressed as mean  $\pm$  std. dev (n = 15).

The chestnut fruits used in the present study presented similar widths ( $2.82 \pm 0.10$ ) and lengths ( $3.17 \pm 0.21$ ), indicating that the fruits were almost round. The thickness was smaller

than the former parameters ( $1.76 \pm 0.25$ ), explaining the sphericity values less than one obtained ( $0.79 \pm 0.05$ ).

### Color

The effect of irradiation on chestnut fruits color was measured for each dose after 0, 15 and 30 days of storage at refrigerated conditions after postharvest treatment. The registered Hunter *L*, *a* and *b* parameters is a three-dimensional space for color. In Table 2A and Table 2B we present only the *L* and *b* values for the whole peeled fruit and half-cutted fruit (interior), *a*-value is close to zero (data not shown).

**Table 2A.** Fruits color parameters (*L*, *b*) of gamma irradiated chestnuts with irradiation dose and storage time.

<i>L</i> -value			
	0 days	15 days	30 days
0 kGy	75.15 ± 2.10	75.33 ± 3.98	75.90 ± 1.72
0.5 kGy	75.17 ± 3.63	75.43 ± 1.41	73.72 ± 2.27 *
3 kGy	73.07 ± 3.38	73.00 ± 3.28 *	73.67 ± 3.52
6 kGy	69.90 ± 5.79 *	71.92 ± 3.13 *	74.39 ± 3.92

<i>b</i> -value			
	0 days	15 days	30 days
0 kGy	29.60 ± 1.72	28.54 ± 2.15	30.34 ± 2.29
0.5 kGy	29.80 ± 2.32	30.34 ± 2.22	29.21 ± 1.96
3 kGy	29.39 ± 1.18	28.25 ± 2.09	29.20 ± 1.17
6 kGy	26.56 ± 2.25 *	29.62 ± 2.24 #, *	28.83 ± 1.88 #, *

**Table 2B.** Fruits interior (half-cutted) color parameters (*L* and *b*) of gamma irradiated chestnuts with irradiation dose and storage time.

<i>L</i> -value			
	0 days	15 days	30 days
0 kGy	84.67 ± 2.23	84.52 ± 1.96	84.25 ± 2.82
0.5 kGy	84.68 ± 1.96	84.39 ± 1.59	83.38 ± 2.82
3 kGy	85.07 ± 1.72	81.86 ± 2.59 #	84.76 ± 1.49
6 kGy	85.31 ± 1.29	84.38 ± 2.63	83.27 ± 4.52

<i>b</i> -value			
	0 days	15 days	30 days
0 kGy	18.80 ± 1.87	18.76 ± 2.50	18.52 ± 2.51
0.5 kGy	18.96 ± 1.30	19.60 ± 0.32	17.50 ± 1.87
3 kGy	19.66 ± 1.62	19.87 ± 2.31	19.08 ± 1.68
6 kGy	17.65 ± 1.87	19.45 ± 1.67 #	19.40 ± 3.23

Values with a superscript, in each row (#) and in each column (\*), are significantly different from the non-stored (0 days) or non-irradiated sample (0 kGy), respectively ( $p < 0.05$ ). Results are expressed as mean ± std. dev.

Irradiation dose (ID) and storage time (ST) both affected *L* and *b* color parameters of chestnuts. A statistical analysis for each single factor was performed, and a means comparison for irradiated and stored samples with non-irradiated and non-stored samples, respectively. From the results presented in the tables, storage time (along rows) and irradiation dose (along columns), we could make same considerations. For fruits, significant differences ( $p < 0.05$ ) were observed on *L*-value (“lightness”) for the higher dose of 6 kGy at 0 days and for higher storage times at lower doses. For fruits interior, no significant differences were observed in *L*-value with irradiation dose, compared to the non-irradiated samples. For *b*-value (“yellowness”) of fruit and fruits interior we did not observed any significant difference for irradiation doses lower than 6 kGy and along storage time up to 30 days. In fruits, for the higher dose of 6 kGy we observed a lowering tendency on *b*-value at 0 and 30 days of storage, maybe due to the stopping of enzymatic processes by the radiation, described by other authors as a ripening delay effect in irradiated fruits (Sabato *et al.*, 2009).

### Texture

The texture values, maximum force of probe penetration, for the chestnut fruits subjected to 0, 0.5, 3 and 6 kGy along 0, 15 and 30 days of storage are reported on Table 3.

**Table 3.** Texture (maximum force, in N) with irradiation dose (ID) and storage time (ST).

ID				
0 kGy	0.5 kGy	3 kGy	6 kGy	p-value (n = 18)
26.3 ± 3.3 <sup>a</sup>	27.4 ± 3.8 <sup>a</sup>	25.1 ± 3.6 <sup>a</sup>	21.9 ± 2.9 <sup>b</sup>	0.0001
ST				
0 days	15 days	30 days	p-value (n = 24)	
25.0 ± 3.0 <sup>a</sup>	25.3 ± 3.6 <sup>a</sup>	25.2 ± 5.1 <sup>a</sup>	0.94	

ST x ID p-value = 0.66

Values with the same superscript are not significantly different ( $p > 0.05$ ).

The results are expressed as mean ± std. dev.

There's no significant interaction between the factors ST (storage time) and ID (irradiation dose), STxID  $p$ -value = 0.66, that allows us to make some conclusions regarding each independent factor, presented graphically in whisker-box plots in Figure 1 and Figure 2.

Regarding storage time, no significant differences were detected on texture up to 30 days of storage at refrigerated conditions (Figure 1).

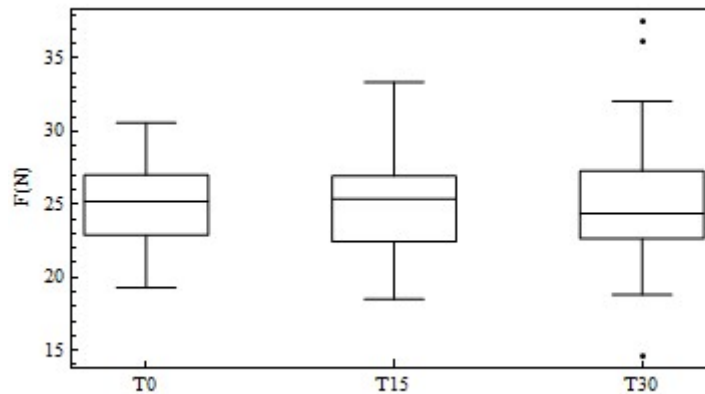

**Figure 1.** Box plot of fruit texture with storage time.

With irradiation dose, it was observed a significant decrease in chestnut fruits texture only for the higher dose of 6 kGy (Figure 2).

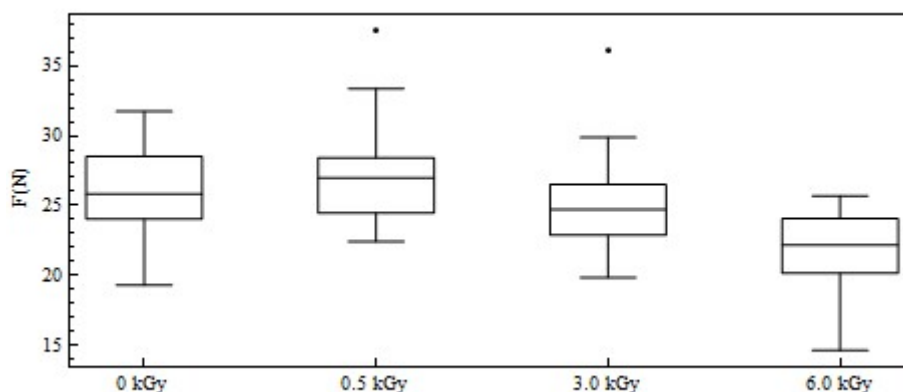

**Figure 2.** Box plot of fruit texture with irradiation dose.

The softening effect in texture of irradiated fruits may be induced by radiation cell wall breakdown (Gandolph *et al.*, 2007).

**Conclusion:**

Irradiation postharvest treatment must be validated for each particular fruit. In this study, the effect of gamma irradiation on color and texture of European chestnut fruit varieties, up to 6 kGy and 30 days of storage time, was reported. For *L-value*, significant differences were observed with irradiation on fruits color for the higher dose of 6 kGy after irradiation and only for lower doses at longer storage times. For fruits interior (half-cutted), no significant differences were observed for doses lower than 3 kGy and along storage time, up to 30 days. For the *b* parameter, no significant differences were observed on color for doses lower than 6 kGy and along storage time up to 30 days, for fruits and fruits interior. Regarding texture, changes were observed only for the higher irradiation dose of 6 kGy. With storage time, up to 30 days at refrigerated conditions, it was not observed any significant difference on texture.

With this study it was possible to identify the maximum acceptable dose for irradiation processing of these fruits. The typical doses for quarantine treatment are lower than 3 kGy, so we can conclude that gamma irradiation could be a promising alternative technology for postharvest disinfestation of European chestnuts varieties, to meet food safety international trade regulations, not affecting significantly two important parameters for the consumer, the color and texture.

**Acknowledgments**

ON.2/QREN/EU project n° 13198/2010 for financial support. A.L. Antonio and Â. Fernandes thank FCT, POPH-QREN and FSE for their grants (SFRH/PROTEC/67398/2010 and SFRH/BD/76019/2011, respectively).

**References:**

- Antonio, A.L., Fernandes Â., Barreira J.C.M., Bento A., Botelho M.L., and Ferreira, I.C.F.R. Influence of gamma irradiation in the antioxidant potential of chestnuts (*Castanea sativa* Mill.) fruits and skins. *Food and Chemical Toxicology* 49, 2011.
- Antonio A.L., Caroch, M., Bento A., Quintana, B., Botelho M.L. and Ferreira, I.C.F.R. Effects of gamma radiation on the biological, physico-chemical, nutritional and antioxidant parameters of chestnuts - A review. *Food and Chemical Toxicology* 50, 2012.
- ASTM E1026: Practice for Using the Fricke Reference Standard Dosimetry System. American Society for Testing and Materials. Annual Book of ASTM Standards, 12.02, Philadelphia, USA, 1992.
- EC European Commission Health and Consumer Protection Directorate-General Scientific Committee on Food, Revision of the opinion of the Scientific Committee on Food on the irradiation of food. SCF/CS/NF/IRR/24 Final Report, 2003.
- EU Directive 1999/2/EC: On the approximation of the laws of the Member States concerning foods and food ingredients treated with ionizing radiation. Official Journal of the European Communities, L(66/16), 13th March, 1999.
- EU Commission Decision concerning the non-inclusion of methyl bromide in Annex I to Council Directive 91/414/EEC and the withdrawal of authorizations for plant protection products containing that substance. Official Journal of the European Union, L(258/68), 26th September, 2008.
- EU List of Member States' authorizations of food and food ingredients which may be treated with ionizing radiation. Official Journal of the European Union, C(283), 24th November, 2009.
- FAOSTAT Food and Agriculture Organization of the United Nations. Available from: <http://faostat.fao.org/site/339/default.aspx>, 2011.
- FAO/IAEA/WHO Wholesomeness of irradiated food. Report of a Joint FAO/IAEA/WHO Expert Committee. Technical Report Series, 659, World Health Organization, Geneva, Switzerland, 1981.

- Gandolph, J. , Shand, A., Stoklosa, A., Ma, A., Weiss, I., Alexander, D., Perchonok, M., and Mauer, L.J. Foods for a Mission to Mars: Investigations of Low-Dose Gamma Radiation Effects. *World of Food Science* 2, 2007.
- INE Portuguese Agricultural Statistics. Instituto Nacional de Estatística I.P., Lisbon, Portugal. <http://www.ine.pt>. 2011.
- Mohsenin N. N. Physical properties of plant and animal materials. Gordon and Breach Sci. Publishers, New York, USA, 1978.
- Molins, R. Food Irradiation: Principles and applications. John Wiley & Sons, USA, 2001.
- Montgomery D.C. Design and Analysis of Experiments. Wiley & Sons, USA, 2001.
- Sabato, S.F., Silva, J.M., Cruz, J.N., Broisler, P.O., Rela, P.R., Salmieri, S. and Lacroix, M. Advances in commercial application of gamma radiation in tropical fruits at Brazil. *Radiation Physics and Chemistry* 78, 2009.
- UNEP. The Montreal Protocol on Substances that Deplete the Ozone Layer. United Nations Environment Programme, 2000.
- Vossen, P. Chestnut culture in California. In Publication 8010, Department of Agriculture and Natural Resources, University of California, USA, 2000.
- Yildiz M.U., Özcan M.M., Çalisir S., Demir F., Er F. Physico-Chemical properties of wild chestnut (*Castanea sativa* Mill.) fruit grown in Turkey, *World Applied Sciences Journal*, 6(3), 2009.

# LONG-TERM PROGNOSIS AND MODES OF DEATH IN HEART FAILURE PATIENTS WITH REDUCED VERSUS PRESERVED LEFT VENTRICULAR SYSTOLIC FUNCTION

*Adelina Mavrea*

*I. Korpos-Gyalai*

*Ioana Citu*

*Oana Ancusa*

*Aurora Bordejevic*

*Mirela C. Tomescu*

University of Medicine and Pharmacy "V. Babes" Timisoara, Romania

---

## Abstract

**Background:** There are conflicting reports regarding the prognosis of heart failure patients with preserved (HFPSF) comparative to reduced systolic left ventricular function (HFRSF). We evaluated the clinical characteristics, mortality rates and modes of death in 309 consecutive symptomatic heart failure patients. In 133(56%) patients LVEF was <50% (HFRSF), and in 133 (44%), LVEF was  $\geq$ 50% (HFPSF).

**Methods:** Three hundred nine consecutive patients hospitalized between January 1, 2009 and January 1, 2010 (176 men and 133 women, mean age 64.3 years) were followed up for a mean period of  $23\pm 14$  months. The severity of symptoms at admission was assessed by NYHA classification. 196 patients were in NYHA class I-II, and 113 in III-IV. All patients underwent chest X-ray, echocardiogram, and a 6-minute walking test. We compared the clinical profiles, mortality rates and modes of death.

**Results:** More than a third (44%) of the patients had preserved systolic LVEF based on echocardiography. Compared to the HFPSF group, HFRSF patients were predominantly younger males with ischemic aetiology and less cardiovascular comorbidities such as obesity, hypertension, diabetes mellitus and atrial fibrillation. During a mean follow-up period of 1.9 years, 22 (7.1%) patients died: 14 of cardiac causes and 8 of non-cardiac causes (4 of respiratory causes, 2 of stroke, 1 of major bleeding and 1 of cancer). Overall mortality was similar between the two groups: 8 (6%) in HFPSF patients and 14 (7.9%) in HFRSF patients ( $p=0.67$ ). HFRSF patients had higher death rates due to pump failure compared to the HFPSF group [5/14(36%) vs. 1/8(12%) patients,  $p=0.5$ ]. Non-cardiac deaths were more frequent in HFPSF group [4/8 (50%) patients vs. 4/14(28%) patients, respectively,  $p=0.5$ ]. The prevalence of arrhythmic death was similar in the two groups [5/14(36%) vs.3/8(37%) patients,  $p=0.6$ ]. With Cox stepwise regression analysis for survival, the independent predictors for mortality were age, gender, ischemic etiology of heart failure and renal impairment.

**Conclusions:** Although the characteristics of HFPSF and SHF patients are different, the mortality rates were similar in our study. The mode of death was different among the two groups of patients, as pump failure death rate was higher in patients with LVEF <50%, while non-cardiac death was higher in heart failure patients with preserved systolic function. The differences were not statistically significant. A high NYHA class at admission, age over 65, male gender and renal impairment were related to a worse prognosis.

---



**Keywords:** Heart failure reduced LV systolic function, preserved LV systolic function, outcome, and mode of death

## Background

Heart failure (HF) represents a significant health problem /1/. Heart failure with preserved systolic left ventricular function (HFPSVF) is a common condition in heart failure patients and represents as a serious clinical problem. The literature indicates that over the last years the number of patients hospitalized with heart failure and preserved LVEF is increasing /2/. The prognosis in these patients was considered to be better than in patients with low LVEF. However, some studies suggest that the outcome in these patients is not so good /3/. Regarding these conflicting data, we aimed to evaluate the mortality and morbidity in patients with heart failure and preserved LVEF compared to those in patients with reduced LVEF.

---

## Methods

Our HF centre is a secondary teaching centre, assembling most HF patients in the south-west counties of Romania. We included in the study HF patients who were hospitalized in our department for symptomatic HF. We reviewed patients' records for clinical, laboratory, echocardiographic and electrocardiographic parameters. 309 consecutive patients hospitalized between January 1, 2009 and January 1, 2010 (176 men and 133 women, mean age 64.3 years). The patients were followed up for a mean period of  $23 \pm 14$  months. The severity of symptoms at admission was assessed by NYHA classification. 65 (21%) patients were in NYHA class I, 131 (42%) in II, and 113 (37%) in III–IV. All patients underwent chest X-ray, echocardiogram, and a 6-minute walking test. We compared the clinical profiles, mortality rates and modes of death. We categorized HFPSF as symptomatic HF patients with left ventricular ejection fraction (LVEF)  $\geq 50\%$  and HFRSF as symptomatic HF patients with LVEF  $< 50\%$  per echocardiogram. We analyzed in-hospital mortality rates. 22 patients (7%) died during the follow-up period. The mode of death was categorized as hemodynamic cardiac death (pump failure), arrhythmic (sudden) cardiac death or non-cardiac. Hemodynamic cardiac death mode was defined as worsening heart failure (cardiogenic shock, pulmonary edema or increase in heart failure symptoms and drug therapy) prior to death. Arrhythmic death mode was defined as instantaneous or acute in clinical setting (within 24 h), in the absence of pre-existing circulatory failure. A non-cardiac death included a variety of etiologies of mortality (stroke, respiratory infection, cancer, major bleeding).

## Data analysis

Continuous data are presented as numbers or means  $\pm$  standard deviation, and categorical variables as numbers and percentages. The independent samples t-test was used to compare continuous variables, and the chi-square test was used to compare categorical variables. Fisher's exact test was used in cases of small sample sizes. Survival curves were plotted by the Kaplan–Meier method, using the log-rank test for comparison between the two ejection fraction groups. In order to determine the adjusted hazard ratio for death among patients with HFRHF and HFPSF, we used Cox proportional-hazards multivariate analysis. The results were considered statistically significant when the p-value was  $< 0.05$ . The MedCalc 12.3.0.0 statistical software for Windows was used to perform statistical analysis. Parameters included in the multivariate stepwise Cox regression analysis included all significant clinical and laboratory parameters, as well as drug treatment, on univariate analysis. Parameters included in the multivariate analysis were gender, age, body mass index, NYHA class at admission, ischemic heart disease, hypertension, diabetes, atrial fibrillation, serum urea, glomerular filtration rate (GFR) for serum creatinine (derived from the MDRD Study equation), NT-proBNP, sodium, hemoglobin, distance at 6-min walk test, ED-5D-5L quality of life score /3/, Hamilton depression score /4/ and LVEF.

## Results

The study analysis included 309 patients who were followed at our HF centre for a mean period of  $23 \pm 14$  months. This cohort of patients included 176 (56%) patients with HFERSF and 133 (44%) patients with HFPSF. Patients' mean age was 64.3 years, 133 (43%) patients were females. Patients' characteristics according to their HF profile (HFERSF/HFPSF) are presented elaborated in table 1. Their baseline laboratory data are detailed in table 2.

Table 1. Characteristics of HFERSF and HFPSF patients.

Variable	EF<50% (n=176)	EF≥50% (n=133)	p-value
Age (years)	66 ±7.5	61± 8.9	<0.0001
Female gender	60 (34%)	73 (55%)	0.0003
Body mass index (kg/m <sup>2</sup> )	31± 6.2	33±2.5	0.0005
Ischemic etiology n (%)	110 (63%)	46 (35%)	<0.03
History of hypertension n (%)	93 (53%)	101 (76%)	0.0001
Diabetes mellitus n (%)	51 (29%)	65 (48%)	0.001
Atrial fibrillation n (%)	56 (32%)	66 (50%)	0.002
Six-minute walk (m)	181± 38	261±64	<0.0001
New York Heart Association Class (1-4)	2.5 ± 0.4	2.1 ± 0.8	< 0.0001
EQ-5D-5L Euro QOL score/4/	50± 15	31.2±12.7	< 0.0001
Hamilton Depression Scale score/5/	8.7±3.1	7.2±2.8	< 0.0001
Beta blockers therapy n (%)	151 (86%)	110 (84%)	NS
ACEI/ARB <sup>b</sup> therapy n (%)	110 (63%)	87 (66%)	NS
Spironolactone therapy n (%)	142 (81%)	47 (36%)	<0.0001
Diuretics therapy n (%)	163 (93%)	119 (90%)	NS

Continuous variables are presented as mean ± 1 standard deviation

EF= ejection fraction; ACEI=angiotensin-converting enzyme inhibitors; ARB=angiotensin receptor blockers.

EQ-5D-5L: measurement of health-related quality of life scale, EuroQOL Group.

Table 2. Laboratory tests of HFRSF and HFPSF patients.

Variable	EF<50% (n=176)	EF≥50% (n=133)	p-value
Hemoglobin (g/dl)	13.8±1.7	14.5±1.8	0.0005
Ht (%)	43.4±5.1	43.6±4.3	NS
Creatinine (mg/dl)	1.18±0.29	0.99±0.28	<0.0001
Urea (mg/dl)	30±19.8	24±11.5	0.002
GFR (ml/min/1.73 m <sup>2</sup> )	57.58±19	74.28±19	<0.0001
Sodium (mEq/l)	136.5 ± 3.2	137.4 ± 3.4	0.01
Uric acid (mg/dl)	6.0±1.6	7.0±3.3	0.0005
Total cholesterol (mg/dl)	157.0 ± 34	163.0 ± 42	NS
NT-proBNP (pg/ml)	821.4±720	520.8±360	< 0.0001

Data are presented as mean± 1 standard deviation

As we see, the clinical profile of the HFPSF patient is different from the HFRSF patient. HFPSF patients are more likely to be younger, have female gender and a higher prevalence of cardiovascular comorbidities, such as obesity, diabetes mellitus, hypertension, renal impairment and atrial fibrillation. Patients with HFRSF are more frequently older men, with ischemic heart disease; they have a higher NYHA class, a higher depression scale score, a lower distance at six-minute walk test, a poorer quality of life and higher levels of NT-proBNP. The treatment in both heart failure group patients was similar, excepting a higher rate of Spironolactone receiving patients among those having LVEF< 50% (p<0.0001).

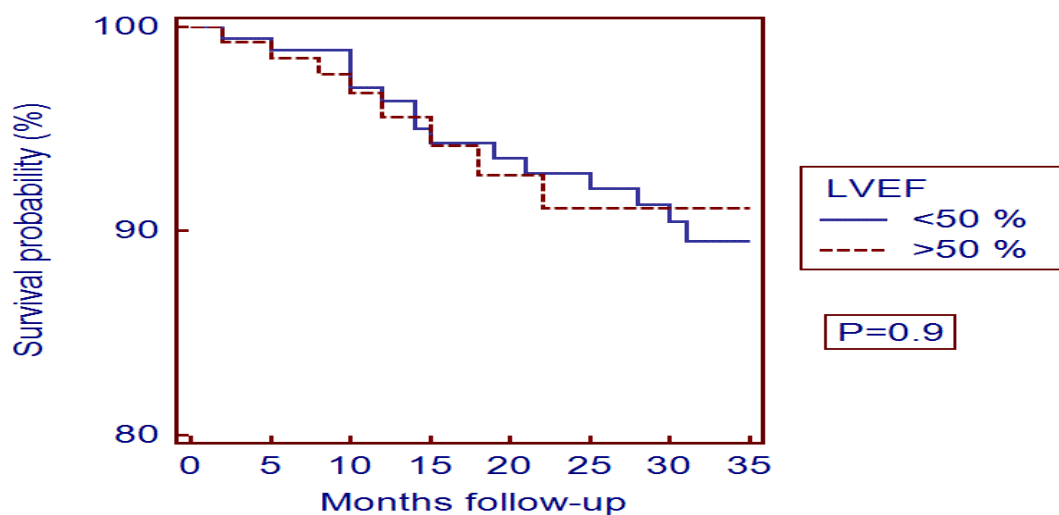

Fig.1. Kaplan–Meier survival curves in HFRSF and HFPSF patients (p-value 0.9, Log-rank test).

During mean follow-up period of 23±14 months, 22 (7%) patients died. The mortality rates of both SHF and the HFPSF patients groups were similar: 14 (7.9%) in HFRSF and 8 (6%) in HFPSF; p=0.67. At log-rank test for Kaplan-Meyer survival curves: p=0.9 (fig.1).

We analyzed the possible association of the following parameters with mortality: LVEF, age, gender, atrial fibrillation, diabetes mellitus, hypertension, ischemic etiology and body mass index (table 3). Using Cox stepwise multivariate analysis, we found that age, gender,

ischemic etiology of heart failure and increased serum urea were independent variables associated with mortality.

Table 3. Cox logistic regression multivariate analysis for mortality.

Variable	HR (95% CI) <sup>a</sup>	p-value
Age	1.04 (1.00–1.08)	0.02
Gender	1.05 (1.05–2.45)	0.006
Ischemic heart disease	1.50 (1.05–2.63)	0.005
Urea	1.03 (1.01–1.06)	0.02
NYHA class	1.42 (1.04– 2.18)	0.03

As demonstrated in fig.3, the HFRSF patients had a higher prevalence of mortality due to pump failure comparing with the HFPSF patients, but the difference was not statistically significant [5/14 (36%) patients vs. 1/8 (13%),  $p=0.5$ ]. The prevalence of sudden cardiac death was similar [5/14 (36%) vs. 3/8 (37%),  $p=0.6$ ]. Non-cardiac deaths were more frequent in heart failure patients with preserved systolic function [4/8 (50%) vs. 4/14 (28%),  $p=0.6$ ](fig.3).

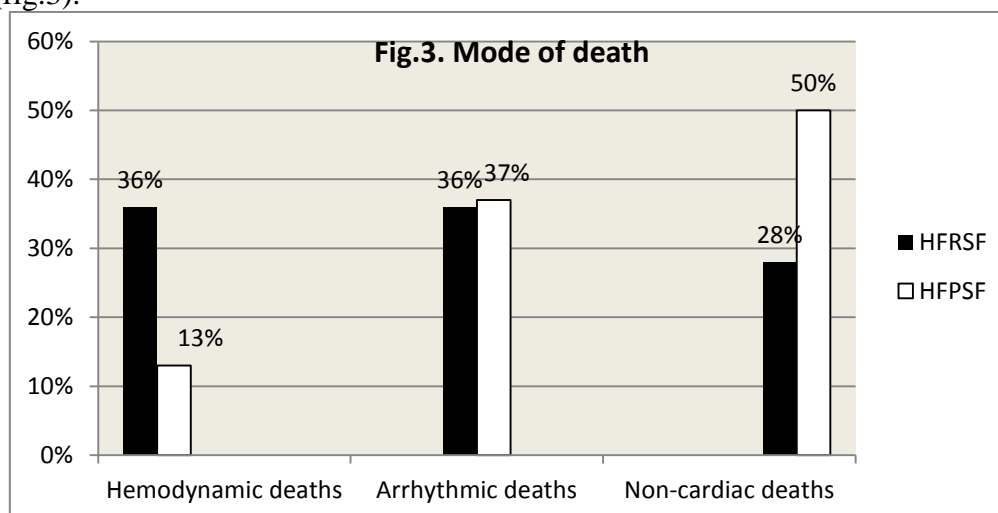

## Discussion

The main finding of this study is that, although there are large differences in the clinical profiles of heart failure patients with reduced or preserved systolic function, mortality is similar.

However, we observe that the prevalence of various modes of death is different. In patients with reduced systolic function, death rate due to aggravated heart failure was 2.7 times more common than in patients with preserved systolic function, while non-cardiac death rate was 1.7 times more common in HFPSF. Arrhythmic (sudden) cardiac death rate was similar in both groups.

There are many controversies regarding HFPSF. In definition, cut-off value of normal LVEF varies between 35% and 50%. Although many studies and guidelines for diagnosing heart failure with preserved systolic function were published in the last years, there is no consent regarding the definition. We chose as cut-off value for HF with preserved systolic function a LVEF  $\geq 50\%$  /8/.

Probably due to definition variations, the prevalence of HFPSF is controversial, between 24% and 60% of the total HF population, usually higher in older HF patients /9,10/.

In our study, HFPSF patients were younger, were more frequent females and had a higher prevalence of cardiovascular comorbidities, such as obesity, diabetes mellitus, hypertension, renal impairment and atrial fibrillation. Similar results were observed in other studies/11, 12/. In contrast, heart failure patients with reduced LVEF were more frequent males and older. Reduced systolic function heart failure was associated more frequent with ischemic etiology, higher levels of NT-proBNP, depression and a poorer quality of life. /13, 14, 15, 16, 17/ Heart failure treatment with beta-blockers, ACE inhibitors, angiotensin receptor antagonists and diuretics was similar in both groups. Spironolactone had a significant statistical higher usage in patients with reduced LVEF, probably due to more severe signs and symptoms of heart failure. /18, 20/.

The mortality rate in our study was 7.1% (7, 9% in HFPSF and 6% in HFPSF patients,  $p=0.67$ ). Over the follow-up period of  $23\pm 14$  months, the total mortality rate was similar in the two groups. The mechanisms of death were different, but no statistically significant. In patients with  $LVEF < 50\%$ , the major cause of death was the aggravation of heart failure. Among patients with preserved systolic function, non-cardiac causes of death (stroke, cancer, major bleeding) were predominant. Sudden cardiac deaths had similar rates in the two study groups.

Our data are concordant to those reported, as several studies demonstrate similar mortality rates among heart failure patients with reduced and preserved systolic function /8,19,22,23,24/.

As regarding medical treatment, excepting Spironolactone, that was used more frequent in patients with  $LVEF < 50\%$ , there were not significant differences among the two groups. The beneficial effect of aldosterone receptor antagonism was demonstrated in systolic heart failure (*Ephesus study*/20/), while its effect in preserved LV heart failure is now being tested (*Treatment of Preserved Cardiac Function Heart Failure with an Aldosterone Antagonist -TOPCAT study*)/21/.

The similar rate of arrhythmic (sudden) cardiac death in the two patient groups leads to the question of a potential benefit of implantable cardioverter-defibrillator devices in patients with heart failure having a preserved systolic function /24/.

## Conclusions

The arbitrary cut-off levels of LVEF in different HFPSF studies lead to controversies regarding the patient cohort.

The prognosis of heart failure patients is poor, indifferent of the LVEF.

Heart failure patients with reduced and preserved systolic function have different clinical characteristics, but similar total mortality rates. Death due to pump failure is higher among patients with reduced LVEF, while non-cardiac death occurs at higher rates in those with preserved LV systolic function.

As arrhythmic cardiac death has similar rates in both types of heart failure, more efforts have to be done to prevent it.

The treatment protocol of HF with preserved LVEF has to be improved.

## References:

- Chatterjee K, Massie B. Systolic and diastolic heart failure: differences and similarities. *J. Card. Fail.* 2007; 13:569-576.
- Bukhoff D, Maurer MS, Parker M. Heart failure with a normal ejection fraction: is it really a disorder of diastolic function? *Circulation.* 2003; 11:656-658.
- Pauaulus WJ, van Ballegoij JJ. Treatment of heart failure with normal ejection fraction: an inconvenient truth. *J Am Coll Cardiol.* 2010; 55(6):526-537.
- M. Herdman et al. Qual Life Res. Health J. DOI 10.1007/s11136-011-99031

- Berrios G E & Bulbena A . The Hamilton Depression Scale and the Numerical Description of the Symptoms of Depression. In Bech P & Coppen A (ed) *The Hamilton Scales*, Heildeberg, Springer.1990; 80-92
- Bhatia RS, Tu JV, Lee DS, Austin PC, Fang J, et al. Outcome of heart failure with preserved ejection fraction in a population-based study. *N Engl J Med*. 2006; 355: 260–269.
- Gotsman I, Zwas D, Planer D, Azaz-Livhits T, Admon D, et al. Clinical outcome of patients with heart failure and preserved left ventricular function. *Am J Med*. 2008; 121: 997–1001.
- Tribouilloy C, Rusinaru D, Mahjoub H, Souliere V, Levy F, et al. Prognosis of heart failure with preserved ejection fraction: a 5 year prospective population-based study. *Eur Heart J*. 2008 Feb;29(3):339-47.
- Solomon SD, Anavekar N, Skali H, McMurray JJ, Swedberg K, et al. (2005) Influence of ejection fraction on cardiovascular outcomes in a broad spectrum of heart failure patients. *Circulation* 112: 3738–3744.
- Maestre A, Gil V, Gailego J, Garcia M, Garcia de Burgos F, Martin-Hidalgo A. Prediction clinical profile to distinguish between systolic and diastolic heart failure in hospitalized patients. *Eur J Intern Med*. 2009;20:313-318.
- Gustaffson F, Torp-Federsen C, Brendorp B, Seibak M, Burchardt H, Kobel L, et al. Long-term survival in patients hospitalized with congestive heart failure: relation to preserved and reduced left ventricular systolic function. *Eur Heart J*. 2003; 24:863-870.
- Owan TE, Hodge DO, Herges RM, Jacobsen SJ, Roger VL, Redfield MM. Trends in prevalence and outcome of heart failure with preserved ejection fraction. *N Engl J Med*. 2006;355:251-259.
- Formiga F, Chivite D, Manito N, Mestre AR, Liopis F, Pujol R. Admission characteristics predicting longer length of stay among elderly patients hospitalized for decompensated heart failure. *Eur J Intern Med*. 2008; 19-202.
- Gustafsson F, Torp-Federsen C, Brendorp B, Seibaek M, Burchardt H, Kobel L, et al. Long-term survival in patients hospitalized with congestive heart failure: relation to preserved and reduced left ventricular systolic function. *Eur Heart J*. 2003; 24:863-870.
- Mehta PA, Dubrey SW, McIntype HF, Walker DM, Hardman SMC, Sutton GC, et al. Mode of death in patients with newly diagnosed heart failure in the general population. *Eur J Heart Fail*. 2008;10:1108–1116
- Miyagishima K, Hiramitsu S, Kinura H, Mori K, Ueda T, Kato S, et al. Long term prognosis of chronic heart failure. Reduced vs preserved left ventricular ejection fraction. *Circ J*. 2009; 73:92–99.
- Poole-Wilson PA, Uretsky BF, Thygesen K, Cleland JGF, Massie BM, Ryden L. Mode of death in heart failure: Findings from the ATLAS trial. *Heart*. 2003;89:42–48
- Fonarow GC, Stough WG, Abraham WT, Albert NM, Gheorghide M, et al. Characteristics, treatments, and outcomes of patients with preserved systolic function hospitalized for heart failure: a report from the OPTIMIZE-HF Registry. *J Am Coll Cardiol* 2007; 50: 768–777
- Lewis BS, Shotan A, Gottlieb S, Behar S, Halon DA, et al. Late mortality and determinants in patients with heart failure and preserved systolic left ventricular function: the Israel Nationwide Heart Failure Survey. *Isr Med Assoc J*.2007; 9: 234–238
- Pitt B, Williams G, Remme W, Martinez F, Lopez-Sendon J, Zannad F, Neaton J, Roniker B, Hurley S, Burns D, Bittman R, Kleiman J. The EPHEsus trial: eplerenone in patients with heart failure due to systolic dysfunction complicating acute myocardial infarction. Eplerenone Post-AMI Heart Failure Efficacy and Survival Study. *Cardiovasc Drugs Ther*. 2001 Jan; 15(1):79-87
- Desai AS, Lewis EF, Li R, Solomon SD, Assmann SF, Boineau R, Clausell N, Diaz R, Fleg JL, Gordeev I, McKinlay S, O'Meara E, Shaburishvili T, Pitt B, Pfeffer MA. Rationale and design of the treatment of preserved cardiac function heart failure with an aldosterone

antagonist trial: a randomized, controlled study of spironolactone in patients with symptomatic heart failure and preserved ejection fraction.

Am Heart J. 2011 Dec; 162(6):966-972.

Orea-Tejeda A, Colin-Ramirez E, Castillo-Martinez L, Asensio-Lafuente E, Corzo-Leon D, et al. Aldosterone receptor antagonists induce favorable cardiac remodeling in diastolic heart failure patients. Rev Invest Clin.2007; 59: 103–107

Gotsman I, Zwas D, Lotan C, Keren A. Heart Failure and Preserved Left Ventricular Function: Long Term Clinical Outcome.PLoS ONE.2012; 7(7):e41022

Carlo Rostagno, Gabriele Rosso, Francesco Puggelli, Gian Franco Gensini Preserved systolic ventricular function heart failure patients referred to a division of internal medicine European Journal of Internal Medicin. 2008 Nov; 19(7): 511-515.

# USING OF ACCELEROMETER IN REHABILITATION OF BRAIN DAMAGE PATIENTS WITH UPPER ARM PARESIS

*Petra Sladkova, M.D.*

*Pavlina Oborna, M.Sc.*

*Olga Svestkova, M.D, PhD, Assoc. Prof.*

Charles University, Department of Rehabilitation Medicine, Prague, Czech Republic

---

## Abstract

Rehabilitation of patients after brain damage is an interprofessional, complex, intensive, long-term process. Often, motor disorder post brain damage results in paresis and causes impairment of upper arm movement pattern. Movement ability of the upper arm is vital for self-sufficiency and activities of daily life.

Special rehabilitation therapeutic techniques must involve the training of new activities including the mechanism of motor learning which is responsible for functional reorganization of the motor cortex regions, and the activation of reserve neurons for reparation.

The aim of the study is to demonstrate that an accelerometer is a suitable instrument for objective monitoring of impairment of the upper arm movement pattern with biofeedback principles.

Another aim of the study is to demonstrate if the FIM test and Jebsen-Taylor (JT) test are appropriate instruments for detecting changes of the upper extremity movement pattern after intensive interprofessional rehabilitation brain damage patients. Clinical study was undertaken with selected patients after brain damage with paresis. The patients attended a rehabilitation day care center for 4 weeks.

The parameter of an all-day movement activity of the upper arm was detected by an accelerometer measurement. The FIM and JT tests were applied at the beginning and after 4 weeks during the final examination.

The results confirmed that an accelerometer is a suitable instrument for detecting of the changes of upper arm movement activity. Analysis of the results confirmed that functional tests, the FIM test and JT test, are sensitive to changes of functional abilities of patients after brain damage.

---

**Keywords:** Upper arm paresis, brain damage, accelerometer, interprofessional rehabilitation

## Introduction:

Rehabilitation intervention of patients with brain damage is an interprofessional, complex, intensive, long-term and individual process. Motor disorder of the brain damage patients is often hemiparesis.

The aim of the study is to demonstrate that a sensor - accelerometer is a suitable instrument for objective monitoring of movement of upper arm with feedback principles.

## I.

New technological developments have led to the production of miniature accelerometer sensors. These sensors are possible to use in clinical rehabilitation setting. The using of accelerometer is possibility for objective functional assessment in rehabilitation (1, 2).

Standardized functional instruments for the assessment of the degree of disability and functional abilities of patients are not usually used in rehabilitation in the Czech Republic.



In neurorehabilitation of the patients with hemiparesis is possible to use accelerometer for monitoring of functional changes of movement pattern (3).

The accelerometer can be used in gait analysis, balance evaluation, fall risk assessment and mobility monitoring (4).

The basic principle is measuring of static and dynamic acceleration. Sensors can be used objectively to quantify amount of movement paretic and healthy upper arm activity (5).



Picture 1, 2 Appearance of sensor – accelerometer

We used 3 different types of sensors: left blue sensor is on the left wrist, right red sensor is on the right wrist and green body sensor on the left hip.

Our clinical study was undertaken with selected patients after brain damage with paresis. 30 patients after brain damage with upper arm activity were measured by accelerometer.

Data from accelerometer monitoring were analysed in special program WMSAPP (Wrist Motion Sensor APPLICATION software) version 0.0.3. The following parameter was all-day percentage movement activity of paretic and healthy upper arm activity. The patients were detected at the first and the last week during 4 weeks in a rehabilitation day care center from 9 a.m. to 4 p.m.

The group A (30 patients with accelerometer), group B (25 patients without accelerometer).

The FIM test (Functional Independence Measures) and Jebsen-Taylor (JT) test were used in both group, experimental and control group, it means in 55 patients.

These tests can detect changes of the upper arm movement pattern after intensive interprofessional rehabilitation brain damage patients. The patients attended a rehabilitation day care center for 4 weeks. The day care center is specialized for individual and group therapy of brain damage patients. All patients in a study have daily 60 minutes of individual physiotherapy and also 60 minutes of individual occupational therapy.

### Data analysis

Special SW - WMSAPP (Wrist Motion Sensor APPLICATION software)

Wilcoxon paired test

Mann-Whitney test

### Methods

55 patients after brain damage with upper arm paresis were randomized to an experimental group (A, n=30) and a control group (B, n=25). Patients in both group attended a rehabilitation day care center for 4 weeks. Patients in group A were measured by sensor - accelerometer for 7 hours per day of first week after admission and the last week in the care center. The FIM and Jebsen-Taylor (JT) tests were applied on all patients at the beginning

and after 4 weeks of rehabilitation intervention during the final examination. Both tests are used for measurement of quantitative and qualitative changes in activities of daily living during rehabilitation process.

## Results

Using of sensor - accelerometer in the experimental group (group A) significantly improved upper arm movement activity, can objectively detected the positive changes in movement spastic pattern. The accelerometer has the role of virtual therapist for the idea of permanent monitoring by the therapist. The patients were more motivated for active cooperation during the whole rehabilitation process.

FIM test was used in all 55 patients. The results showed more significantly improvement of all items of activities of daily living in FIM test in group A than in group B.

Jebsen – Taylor test was used in all 55 patients. The results did not showed significant difference between measured time of activities of daily living between group A and group B.

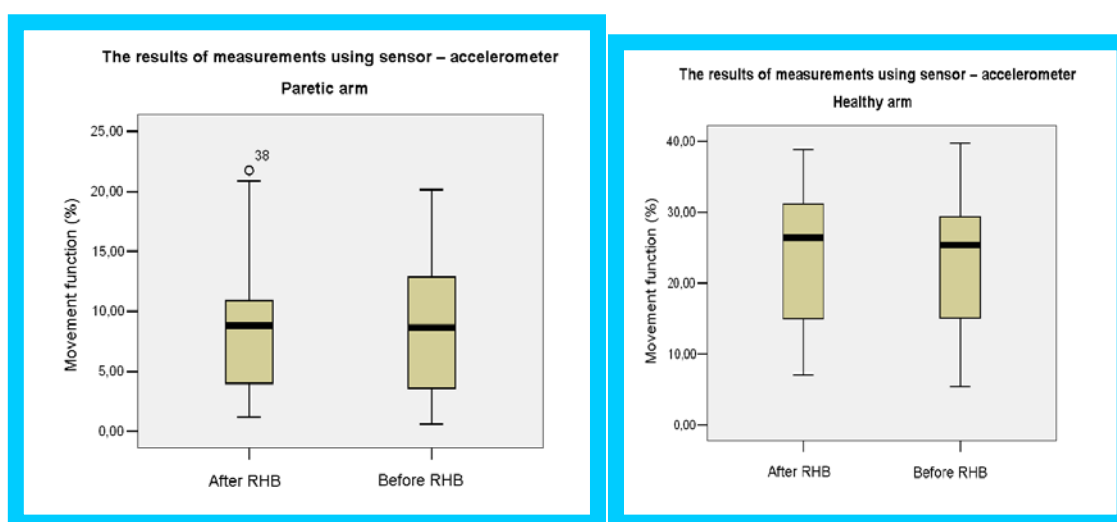

Graph 1, 2 Results of measuring by accelerometer – paretic, healthy arm.

## Conclusion:

Sensor – accelerometer can improve motivation (virtual therapists) of patients and also improve movement pattern and functioning of upper extremity. Activities of daily living of the patients with brain damage are also better.

It is possible to use the mechanism of neuroplasticity in intensive interprofessional rehabilitation intervention of patients after brain damage also long time after their illness or injury.

## References:

- Culhane, K. M., et al. Long-term mobility monitoring of older adults using accelerometers in a clinical environment. *Clinical Rehabilitation*. 2004, vol. 18, s. 335-343.
- Gebruers, N., et al. Monitoring of physical activity after stroke: a systematic review of accelerometer-based measures. *Physical Medicine and Rehabilitation*. February 2010, vol. 91, s. 288-297.
- In, TS, et al. Virtual reality reflection therapy improves motor recovery and motor function in the upper extremities of people with chronic stroke. *Journal of Physical Therapy Science*. 2012, vol. 24, issue: 4, s. 339-343.
- Evans, CC, et al. Evaluation of an interdisciplinary team intervention to improve therapeutic alliance in post-acute brain injury rehabilitation. *Journal of Head Trauma Rehabilitation*. 2008, vol. 23, issue: 5, s. 329-338.
- Uswatte, G., et al. Objective measurement of functional upper – extremity movement using accelerometer recordings transformed with a threshold filter. *Stroke*. 2000, vol. 31, s. 662-667

# PSYCHOTHERAPY IN GEORGIA: PAST, PRESENT AND FUTURE

*Revaz Korinteli, Full Prof.*  
Grigol Robakidze University, Georgia

---

## Abstract

The presented article describes the social, political and economic conditions influencing psychotherapy in post-Soviet Georgia. The author describes the so-called post-Soviet phenomena and defines its following aspects: 1. Master-Slave Relationship between the State and the People ; 2. Nostalgia for the Past and Idealisation of the Soviet Times; 3. Identity Crises; 4. Materialistic World View ; 5. Societal Traumas; 6. Political-economic Conditions. The paper describes the correlation between the post-Soviet phenomena and the challenges of practising psychodynamic psychotherapy.

---

**Keywords:** Soviet and post Soviet mentality, idealization, identity crises, psychotherapy

## Introduction:

The purpose of this paper is to give a short overview of the social, political and economic conditions influencing psychotherapy in Georgia. In order to explain the conditions of psychotherapy in Georgia, I will give the reader a brief review of the phenomena that we inherited from the Soviet Union. The collapse of the Soviet Union gave birth to 15 independent states and dozens of expected and unexpected challenges that are described as the Post-Soviet Phenomena (Urbanovich, 1999; Watson, 2002 ). Full comprehension of these phenomena, in many cases, requires interdisciplinary approach, which may include psychodynamic one. In my article I will try to define some of the phenomena, in general terms, and provide their brief illustration from the dynamic point of view.

## The Past

**The Soviet Mentality.** The Soviet ideology has had an important influence upon the development of psychiatry in Georgia. The Soviet mentality included: 1. Biological world view; 2. Authoritarianism; 3. Intolerance against dissidence.

**Materialistic world view.** During the Soviet times, psychiatry was based on the materialistic understanding of a human being. Disease was regarded as disordered brain functioning caused by distorted biochemical machinery. Mentally ill people were considered to be unnecessary and useless; they were regarded as broken bolts of the big state economic machine. Psychic disturbances were only considered on a somatic level (Calloway, 1993). Patients were labelled with a diagnosis. At the same time psychogenesis of mental disorders was completely disregarded; psychodynamic approach and psychoanalysis were rejected and even forbidden as being bourgeois ( Miller, 2001).

**Authoritarianism.** The relationship between the State and people can be characterised as the one between a Master and a Slave ( Hegel, 1807). The state power, especially the Leader, has always been identified as a masculine human being - a strong, just, merciless father, who protects, supports and takes care of the people (Urbanovich, 1999). Yet Russia was a closed and isolated political system. It was based on dogmatization of social life and society, with rigid norms to which one had to

conform and obey (Chaadayev, 1970; Kliuchevskii, 1960). In this grey and oppressive atmosphere, people had to conform to survive. Such a system can give birth to a benevolent dictator or a “tyrannical omnipotent father.” The psychotherapy in the former Soviet Union and in the Post Soviet time could be described as authoritarian, hierarchical, psycho-educational, and directive (Calloway, 1993). Predominance of this style in psychotherapy especially in group psychotherapy was clear. Group reflects the political macrocosm as a mirror.

**Intolerance against dissidence.** Snezhnevsky A. (1972) widened the frames of Schizophrenia. People who were against the Soviet regime could be treated as having personality disorders or psychosis with slow-flow Schizophrenia i.e. Psychopathic-like Schizophrenia. Thus, there was theoretical and legal substantiation for using compulsory, involuntary treatment of dissidents in psychiatric hospitals. Sane people were admitted to psychiatric hospitals and treated against their will (Calloway, 1993). The practice began with the revolution. However, it was only from the 1960s onwards, with the growth of civil rights movements within the Soviet Union, that there was awareness of the issue in the West.

### **The events in the Soviet Union which contributed to align the psychotherapy in Georgia with the western approaches**

During the early years, there was a small psychoanalytical movement based in Moscow. In the 1920s, there was a Moscow section of the International Psychoanalytical Association. Russian Psychoanalytical Society was disbanded in 1933.

**Georgian psychiatry differed from the Soviet one.** The founder of the Georgian institute, Mikhail Asatiani, practiced psychoanalytical treatment. In 1908, he met C.G. Jung. After this event, the outline of C.G. Jung's Analytical Psychology was published for the first time in the history of the Russian psychiatry (Asatiani, 1910).

The tradition of psychodynamic approaches was continued by Serge Tsuladze who studied medicine psychiatry and psychoanalysis in Paris at Sorbonne University (Miller 2001). He was analyzed by the famous French psychoanalyst Francoise Dolto. In 1961, he came back to Georgia and started to work in M. Asatiani's Research Institute of Psychiatry in Tbilisi Georgia.

In 1978, the conference was held in Tbilisi dedicated to the problems of unconsciousness. This conference was attended by: G. H. Pollock from Chicago Institute for Psychoanalysis; S. Ariety from New York Medical College; R. Jacobson from Harvard University; D. Anzieu and S. Leclaire from Paris University; G. Ammon from German Academy for Psychoanalysis and others (A Collective Monograph, Tbilisi, 1978).

**Uznadze Theory of Set.** The contribution of the Georgian school of Psychology and its founder D. Uznadze (1887-1950) is worth mentioning. He was the first Soviet psychologist to acknowledge and experimentally prove the ontological existence of the unconscious mind. He elaborated the Theory of Set, according to which the unconscious exists as a set (Uznadze 1966). He emphasized the fact that in classical Depth Psychology, the ontological content of the unconscious is substantiated theoretically but not empirically (the unconscious is a hypothesis but not reality). The ontological nature of the unconscious is a Set that cannot be conceived of in purely physiological or purely mental terms. The general structure of psychic reality implies not only consciousness and the unconscious mind taken together, but Set as a certain protopsychic state of integrity, underlying the realization of consciousness and unconsciousness, including a full realization of the personality. This resembles the Jung's notion of psychoid pole.

**The Leningrad and Moscow Schools of Psychotherapy.** Personality theory based upon the theory of otnoshenia was developed by V.N. Miasishchev (1893-1973). Miasishchev considered that the most important aspect of personality was the system of

relationships/attitudes or *otnoshenia* (especially the social relationships), but this was not independent of the functioning of the brain or Pavlovian physiological Principles (Miasischev, 1960). Pathogenetic psychotherapy was the only dynamically oriented psychotherapeutic approach within the Soviet Union. The aim of pathogenetic psychotherapy is reconstruction of the disturbed system of relationships/attitudes.

The psychology of relationships/attitudes is becoming increasingly used in the Soviet psychotherapy. The Group Psychotherapy based on this theory was well developed in St Petersburg (Karvasarsky 1975 ). In Moscow Prof. V. E. Rozhnov used the so called emotionally stressed Psychotherapy in individual and group forms. The both theories were taught at the All-Union psychotherapy centre. The All Union psychotherapy centre helped psychotherapists from all over the Soviet Union to learn more about depth psychology and group psychotherapy.

**Rehabilitation** has a special place in the Soviet Psychiatry. Professor M. M. Kabanoff was the Director of St Petersburg Bekterev Psychoneurological Research Institute. He was the Director of the first rehabilitation Psychiatric department in the USSR. He considered Rehabilitation as a dynamic system of measures and activities that included medical, psychological and social ones. The rehabilitation concept developed by him and his associates had wide application in medical practice in USSR (Kabanoff, 1978).

## Current Characteristics

### The Post Soviet Mentality

**Master-slave relationship between the state and people.** This type of relationship still exists in the psyche and mind of some people. They can see the leader as a saviour and project their own responsibility onto the leader. That is why the remnants of directive style still exist in psychotherapy.

**Nostalgia for and Idealization of the Soviet Times.** For some, the Soviet times was a period identified with the archetypal dream of the Golden Age or Paradise, where everything is provided in abundance for everyone, and where a great, just and wise leader rules over a human kindergarten (Jung, 1970). In ideal socialism, it is supposed that society has to be structured as one big family where the majority of the population are children or junior members of the family (Jung, 1970). They do whatever they are told to do and proceeding from the results of the assigned work, they are praised or punished. People feel safe as long as the responsibility for supplying their basic needs is fulfilled by their parents, what means members of the ruling class (Urbanovich, 1999).

Hard economic and politic times prepared the ground for idealisation of the Soviet Past. This, after all, is already a period of economic difficulty which only accentuates the problems of the nearly 40% of Georgia's population that live in poverty (Rayfield, 2009). There is a denial of the harsher realities of the Soviet reign. Unfortunately, it forms the attitude of fear towards everything new that future can offer. The replacement and repair work is ongoing, but what is most difficult to mend is the shattered confidence of foreign investors and of international and local business.

**Identity Crisis.** A trauma for the Georgian State was the loss of its territories and distortion of its territorial integrity. The country got split, causing people to lose links to each other. The harshness of economic realities after the break up also contributed to an identity crisis. Compared to the big European Empires, the Soviet Union was unique. More than 100 nations having different ethnic roots, languages and religious beliefs lived together for centuries, first within the Russian Empire and later within the Soviet Union. Russia never had overseas colonies. Russia did not have an identity independent from its colonies; there was never a clear division between Russia, as a nation, and Russia, as an imperial power. Economy, very hard condition of life caused depreciation of idea of social justice and protection.

## **Socio-economic traumas**

### **Catastrophic Events.**

**April 9, 1989.** This mass meeting promoting independence was attacked by military forces of the Soviet Empire; 21 people were killed. April 9 has become a symbol of the innocent heroes sacrificed for independence of their motherland. A year later, on April 9, 1990, the Parliament adopted and signed the Declaration of Independence of Georgia and thus mourning was transformed into celebration. April 9 became the symbol of National Independence (Baltic Assembly, 1989; Sarjveladze, 1999).

**1991-1992.** This was the period of ethno-conflict in South Ossetia. More than 25,000 Georgians were expelled from Tskhinvali, and many Ossetian families were forced to abandon their homes in the Borjomi region and move to Russia. Although the ethnic clashes are over and there seems to be a certain progress achieved in the Georgian-Ossetian conflict regulations, the problem is an unhealed wound representing distorted territorial integrity (Cousens, 1997).

**Civil War.** In December of 1991 and January of 1992, there was a civil war in Tbilisi. This was the war between brothers just in the very heart of Tbilisi, in front of the Governmental House. The President of Georgia Z.Gamsakhurdia fled from the country.

**War in Abkhazia.** In 1992-1993 there was a war in Abkhazia. In this war, both Georgians and Abkhazs were cruelly victimised and heavy casualties were reported. Supported by Russia (HRWAP, HRWH, 1995), Abkhazia achieved and maintained de facto independence from Georgia. More than 250,000 Georgians were ethnically cleansed from Abkhazia by Abkhaz separatists and North Caucasians volunteers (Dale, 1996). In 1992-1993, the Georgian party lost the war, and as a result, there are thousands of Georgian IDP (Internally Displaced People) living in very hard conditions within the territory of Georgia and also out of its borders. Having abandoned their property and much of their belongings, some refugee families from Abkhazia are homeless. Abkhaz side compensated its losses and healed its trauma through the Victory Syndrome (Sarjveladze, 1999) and by the de-facto gained independence (Dale, 1996; Sarjveladze, 1999). But the trauma on the Georgian side is still felt by many who are aggravated by the Syndrome of Defeat and heartache for the lost territory (Sarjveladze, 1999). Hostilities, hostage-taking, criminal and terrorist acts are frequent in the region of Gali. As a result, the neurotic traumatic reactions associated with post-traumatic stress disorders persist. Time passes and no progress seems to be achieved in negotiations and Uncertainty Syndrome (Sarjveladze, 1999) makes the situation worse.

**War with Russia.** After the war with Russia, approximately 20,000 Georgians were displaced who - in addition to the many thousands more forced into flight by the conflicts of the early 1990s - need to be rehoused and provided with the means of access to food and healthcare. The damage to Tbilisi, capital of Georgia, economically and politically, was severe. There was severe destruction of roads, installations and army bases, and housing of approximately 20,000 ethnic Georgians. The more definitive loss of the two territories was less easily quantifiable or repairable (Rayfield 2009).

### **Political Events**

The State of Georgia was in an embryonic state. Numerous political parties were furiously struggling for the power. The corruption rate was/is high and spreading. It was not and is not easy to struggle against corruption when most of the population is unemployed. People live in fear but their main goal is to survive. Deep existential crisis is manifested. The rates of lethality and depopulation are high. The suicide rate is high. The stress of uncertainty penetrated most layers of the population (HRIDC, 2002).

**Rose Revolution.** Massive political demonstrations (the so-called "Rose Revolution") were held in Tbilisi between November 20 and November 23, 2003. Many called the change of government a popular coup. Opinion polls suggest the President M. Saakashvili had been

the country's most popular politician, but critics describe him as a demagogue and a populist with a strong lust for power.

After the Rose Revolution, bold measures to fight corruption were taken. However, afterward, antidemocratic tendencies emerged and human rights violations flourished. The judiciary was seen as the government's "appendix" (Amnesty International Georgia 2005; Humans Rights Watch 2005). There are mass dismissals of civil servants caused by reorganisations in governmental structures and no unemployment benefits. According to "Reporters without Frontiers" (HRIDC Reports 2005), the media freedom index of Georgia continues to drop catastrophically and moved back 26 steps. The current government has become the object of criticism of several national and international human rights organizations, such as Amnesty International, British Helsinki Human Right Group and etc. These organizations have become increasingly concerned about the pressure on the judiciary by the procuracy and other government authorities. There also have been concerns about the freedom of the media. Georgia is still more authoritarian than it was in 2003: people are careful about what they say on cell phones or write on the internet, and researchers for foreign firms are now hard to find (Rayfield 2009). There is a tendency toward fragmentation of society and to Dysutopian anarchism, a contentious "us - over -them" culture (Ettin& Cohen 2003). There is danger of a return to an authoritarian and totalitarian structure. One can imagine how difficult it would be to provide psychotherapy under these conditions.

## **Current State Of Psychotherapy**

### **Clinical challenges**

**Paternalistic Models.** Within the frame of the paternalistic model of psychotherapy, a psychotherapist is regarded as an Authority. Most patients project the archetype of the Saviour or Inner Healer on to the psychotherapist; they do not take responsibility for his/her cure. A patient cannot accept that a psychotherapist awakens, develops and promotes a person's own self-healing capacities (Groesbeck & Taylor 1977). As a result, any attempt to create an analytical working alliance in the form of individual or group psychotherapy can be experienced by some patients as a lack of therapeutic skill on the part of the psychotherapist.

**Nostalgia for the Past.** Nostalgia for the past causes estrangement and aloofness from the present, strengthens rigidity of life stereotypes, conservative tendencies and leads to fear of novelty (Van Der Kolk,&Van Der Hart, 1991). Psychotherapy is dealing with breaking down of habitual stereotypes; it aims at the formation of a new orientation to the present and the creation of an awareness of the future and its possibilities. This all too often clashes with the patient's too understandable fear of the future and novelty, with his or her idealisation of the past and desire to cling to the security of the familiar.

**Materialistic Worldview.** Georgian patients seem to prefer biological, medicinal treatment and consider it the main form of treatment; psychotherapy is secondary. Most patients do not believe that the psychogenesis of mental disorders plays a role in treatment. This world view presents a challenge for the psychodynamically oriented psychotherapist.

### **Current And Future Challenges**

After the breakdown of totalitarian and authoritarian ideology, the possibility of integrating western psychotherapeutic approaches emerged.

In order to improve psychotherapy services in Georgia and to bring its practice closer to Western standards, the author believes the following steps are necessary: 1. Establishment of a model of scientific psychotherapy based on scientific pluralism which includes both the assurance of multiplicity of methods and the status of scientific discipline; 2. Form the necessary theoretical and practical preconditions for establishing psychotherapy as an independent scientific discipline in Georgia; 3. Bring psychotherapy in Georgia closer to the western standards.

Since the collapse of the USSR, the number of associations have been set up. They closely cooperated with the western associations. Several joint projects were launched in Georgia to bring psychotherapy to the western standards. I would like to mention some of them. These are: 1. The Association of Psychotherapists and Clinical Psychologists of Georgia became an associated member of the European Association for Psychotherapy which was established by a number of European countries. 2. The Georgian Group of Psychotherapy Association was founded in 2003 and it is in close cooperation with American Group Psychotherapy Association. 3. The Georgian Association of Analytical Psychology was founded in 2002 and it works in close association with the International Association of Analytical Psychology to fulfill the Georgian Training Project. This project started in 2002 with the intention to train local mental health workers in depth psychology. They have close contacts with French school of psychoanalysis, Lacanien School "Espace Analytic". LaMaisonVerte has been functioning since 2003 in Tbilisi. 4. Georgian Psychoanalytical Psychotherapeutic Society is an associated member of European Federation of Psychoanalytical Psychotherapy and closely collaborates with it. 5. The Caucasus Institute of Gestalt Therapy and Family Psychotherapy cooperates with the International Gestalt Therapy Associations and it has 4 year certified course of Gestalt Therapy.

These Associations try to establish close scientific contacts with the representatives of different psychotherapeutic schools. For this purposes the members of the Associations try to attend the congress and conferences organised by European Association for Psychotherapy, World Association for Psychotherapy, the IAAP, AGPA and IAGP.

### **Conclusion:**

The collapse of the Soviet Union gave birth to 15 independent states and dozens of expected and unexpected challenges that are described as the Post Soviet Phenomena. The Soviet Mentality included: .materialistic, biological world view, authoritarianism and intolerance of dissidence. The Post Soviet mentality is characterized by master-slave relationship between the state and people, nostalgia for and idealization of the Soviet times, identity crisis, socio-economic traumas and political and economical conditions. Current and future challenges consist of improving psychotherapy services in Georgia and bringing its practice closer to western standards.

### **References:**

- A Collective Monograph. The Unconscious. Tbilisi: Metsniereba, 1978.
- Torture and Ill-treatment Still a Concern after the Rose Revolution. Amnesty International, Georgia, 2005.
- Asatiani, M. The Present State of Psychoanalysis Theory and Practice Matter According to Jung's View. The Georgian Psychiatry News. 1, 26-29. 2001.
- Baltic Assembly. Resolution of the Baltic Assembly on the Events in Georgia on April 9, 1989. Tallin: Valgus Publishers.
- Calloway. Russian/Soviet and Western Psychiatry: Wiley Series. 1993. 216 p.
- Chaadayev P. Y. Philosophical Letters & Apology of a Madman. University of Tennessee Press, 1970. xi + 203 pp.
- Cousens D. Preparations for Rehabilitation Actions in South Ossetia and the Georgian-Ossetian Conflict Zone. Internal EU Document. Tbilisi, 1997.
- Dale C. Abkhazia and South Ossetia: Dynamics of the Conflicts. In P. Baev & O. Berthelsen. Conflicts in the Caucasus, PRIO Report 3, 96, Oslo, 1996.
- Ettin M. F. & Cohen. B.D. Working Through a Psychotherapy Group's Political Cultures. International Journal of Group Psychotherapy. 53 479-504. 2003.
- Groesbeck J. & Taylor, B. The Psychiatrist as Wounded Physician. The American Journal of Psychoanalysis. 37,131-139. 1977.



- Hegel G. W. F. *Phenomenology of Mind*. N Y: Harper & Row Publish. 1967.
- Human Right Watch Arms Project. Human Right Watch/Helsinki, 1995.7, 7.
- Human Rights Information and Documentations Centre. (HRIDC). *An Alternative Report on Economics Social and Cultural Rights in Georgia*. 2002.
- Human Rights Information and Documentations Centre's Reports. *Next Stop – The Belarus? Human Rights in Georgia*. 37-38. 2005.
- Human Rights Watch. *Georgia & European Neighbourhood Policy*. 2005.
- Jung C.G. (Editor), Von Franz M. L. & Henderson J.L. *Man and His Symbols* by Doubleday & Company Inc., Garden City, New York, 1970.
- Kabanoff M. M. *The Rehabilitation of Psychotic Patients*. Leningrad, 1978.
- Karvasarsky B. *Group psychotherapy*. Leningrad, 1975. 180 p.
- Kliuchevskii V. O. (1911-31; repr. 1960). *A History of Russia tr.*, V, 5.
- Miasischev V. *Personality and Nevroses*. Leningrad, 1960. 217 p.
- Miller M. *Freud au Pays des Soviets*. Paris: Le Seuil, 2001.
- Rayfield D. *The Georgia-Russia war, a year on [www.opendemocracy.net](http://www.opendemocracy.net)* 2009.
- Sarjveladze N. *Societal Trauma, the Phenomenon of Return and Aspiration*. The Conference Proceedings. Tbilisi, 1999. 63-65 p.
- Sneznevsky A. *Schizophrenia Multidisciplinary Research Med*. Moscow, 1972.
- Strayer R. *Why did the Soviet Union Collapse?* Armonk, N. Y: M. E. Sharp, 1998.
- Urbanovich Y. *Psychodynamics of Post-Soviet Phenomena -Russian Case*. The Conference Proceedings Tbilisi, 1999. 67-68 p.
- Uznadze D. N. *The psychology of Set*, Ed. Joseph Wortis, trans. Basil Haigh, N Y: New York: Consultants' Bureau, 1966.
- Van Der Kolk B. & Van Der Hart O. *The Intrusive Past: The Flexibility of Memory & the Engraving of Trauma*. *American Imago*, 48: 425- 454, 1991.
- Watson E. W. *The Collapse of Communism in the Soviet Union*. Greenwood Publishing Group, 2002. 200 p.

# MOLECULAR GENETIC DETECTION OF BACTERIAL VAGINOSIS AT KAZAKH WOMEN IN REPRODUCTIVE AGE

*Axoltan Oradova, PhD*

*Bilimzhan Duysembayev, PhD, Associate Prof.*

Kazakh National Medical University named by S.D.Asfendiyarov, Almaty, Kazakhstan  
Central Clinical Hospital Medical Center of President's Affairs Administration of  
Republic of Kazakhstan Almaty, Kazakhstan

---

## Abstract

**Introduction:** The diagnostic of sexually transmitted infection (STI) sharply increased. Steady growth of STI at persons of young age, women of fertility age who are often accompanied by the complications leading to disability, to infertility, a pre-natal infection is observed, causing fruit and newborn diseases. The purpose of our study was to analyze the molecular genetic detection of bacterial vaginosis at women in reproductive age by noninvasive methods.

**Materials and Methods:** Total DNA was isolated was extracted from vaginal samples at 54 women between the ages of 15 and 45 years who were able and willing to give informed consent. The analysis of products of PCR of amplification carried out by PCR in real time.

**Results:** It is revealed that associations bacterial vaginosis less often met three infectious agents in comparison with one and two (18, 5±3, 5 %, 38,9±6,3 %, 42,6±6,5 %, respectively, (p<0,05).

**Conclusion:** Our study demonstrates that, using a panel of DNA by means of PCR in real time the identification of BV patients with minimally invasive techniques.

---

**Keywords:** Bacterial vaginosis (BV), polymerase chain reaction real time (PCR-RT), sexually transmitted infection (STI), inflammatory diseases of bodies of a small basin (IDBSB), morbidity and mortality

## Introduction

Bacterial vaginosis (BV) is a common cause of vaginal discharge in women of reproductive age [1]. In fact, numerous observational studies cite BV as the most common cause of symptomatic vaginal discharge during reproductive years with a prevalence of 10–15% [2]. Depending on geographic, racial, and clinical characteristics of a given population; BV has been observed to exhibit a wide-ranging prevalence from 4 to 64%. A total of 800 000 pregnancies in the USA are affected by BV annually [3]. Similar prevalence exists in both the pregnant and non-pregnant states. Asymptomatic women, whether pregnant or not, exhibit a prevalence of 12–25% [4].

Diagnosis in the clinical setting is accomplished by two common methods: microscopic examination of vaginal discharge for clue cells and Whiff Test (sometimes referred to as the 'sniff test') in which KOH (potassium hydroxide) is applied to a vaginal swab to detect a release of amine odor that is sniffed by the clinician. The Whiff Test is deemed positive when an amine odor, sometimes described as similar to that of decaying fish, is sensed by the clinician [5]. Investigation by Hillier (nj 2000) showed microscopic finding of clue cells to be 43.1% sensitive and 99.6% specific for presence of BV. The same investigation showed the Whiff Test to be 6.58% sensitive and 73.6% specific for BV [6]. The Amsel criteria for

diagnosis of BV include the following: vaginal pH > 4.5, abnormal discharge, clue cells, and positive sniff test.<sup>5</sup> Presence of three out of four criteria is considered to be diagnostic for BV in the clinical setting. The gold standard for BV screening in investigations is the Nugent score which entails generation of a scaled score 0–10 in which 0–3 is negative, 4–6 is intermediate, and ≥7 is positive for BV [7].

In recent years the importance of sexually transmitted infection (STI) sharply increased. Steady growth of STI at persons of young age, women of fertility age who are often accompanied by the complications leading to disability, to infertility, a pre-natal infection is observed, causing fruit and newborn diseases. One of the aspects testifying to the high importance of STI, their influence on the course of pregnancy, its outcomes and a state of health of the newborn is. According to the Centers for control of diseases (the CDC USA), at pregnant women most often come to light such STI as bacterial vaginosis (BV), the herpetic and chlamydial infection, is more rare trichomoniasis, gonorrhoea, syphilis and HIV infection. However frequency of the perinatal infection connected with separate STI, is defined not only their prevalence in population, but also transmission frequency. The risk of perinatal infection makes about 30 % for gonococcus, 20-50 % for mycoplasma, 20-40 % for chlamydia, 5-50 % for a herpetic infection and about 50 % for syphilis. The risk of perinatal infection of the newborn is highest at a sharp primary infection [8].

Despite ambiguity of opinions of researchers in an pathogenic role of *Ureaplasma* spp. and *Mycoplasma hominis*, in etiological classification of World Health Organization [9] and syndromal classification of Centers for Disease Control and Prevention [10] these microorganisms are allocated as possible etiological agents nonspecific not gonococcal urethritis, inflammatory diseases of bodies of a small basin and bacterial vaginosis. Without adequate therapy at a third of the infected women develop IDBSB [11]. The question of what conditions are decisive for realization of pathogenic potential of opportunistic mycoplasmas, so far remains obscure. Numerous researches testify that it is possible to judge an etiological role of the specified activators with this or that share of probability only by results of the quantitative analysis. The standardized approaches to laboratory verification of the diagnosis of a urogenital infection are developed insufficiently.

The aim of this study is to determine the sensitivity, specificity and the predictive value of the BV and to observe the risk factors associated in the study of 54 women with BV in association with pathogenic and/or opportunistic causative agents of infections of a urogenital path (*Chlamydia trachomatis*, *Ureaplasma urealyticum* and *Mycoplasma hominis*).

### **Materials and Methods:**

This enrollment began conducted in molecular-genetic laboratory at Scientifically Research Institute of Fundamental and Applied Medicine named by B. Atchabarov (SRIFAM) of Kazakh National Medical University named by S.D. Asfendiyarov, Almaty, (KAZNMU), Kazakhstan from September 2011 to December 2011. Funded by Ministry of Education and Science of (Republic of Kazakhstan) Grant: No. of state registration 0111PK00487 2011. Women that were eligible for project included Russian-speaking women between the ages of 15 and 45 years who were able and willing to give informed consent. Informed consent was received for all participants who were 18 years old.

As a result of the conducted complex laboratory testing at 96 (65, 8 %) women at the time of the address it was diagnosed bacterial vaginosis and at 50 (34, 2%) - a normal state of microflora of a vagina (control group). 96 patients with bacterial vaginosis were divided into 3 groups:

Group I - 30 (31, 3%) women with bacterial vaginosis;

Group II - 12 (12, 5%) women with bacterial vaginosis in association with Candidiasis vulvovaginitis;

Group III - 54 (56, 3%) women with bacterial vaginosis in association with pathogenic and/or opportunistic causative agents of infections of a urogenital path (*Chlamydia trachomatis*, *Ureaplasma urealyticum* and *Mycoplasma hominis*).

Selection criteria in group of patient's bacterial vaginosis were: reproductive age; lack of pregnancy and lactation; lack of system and local antibacterial therapy within 1 month before the real inspection; clinical-microbiological confirmation of the diagnosis bacterial vaginosis; existence of complaints.

Selection criteria of patients in control group were: reproductive age; lack of pregnancy and lactation; lack of system and local antibacterial therapy within 1 month before the real inspection; clinic microbiological confirmation of a normal state of vaginal microflora and excluded STD; absence of complaints.

At the baseline and follow-up visits, a trained nurse conducted a physical examination (including a pelvic examination) and collected endocervical specimens for testing for sexually transmitted infections. Women with bacterial or protozoan STIs were treated according to CDC guidelines [12].

Total DNA from vaginal samples was isolated using the DNA sorb-AM nucleic acid extraction kit (AmpliSens) according to the manufacturer's guidelines. DNA was allocated on an amplificatory "Rotor-Gene 6000 (Corbett Research, Australia) by set of reagents for DNA identification in a clinical material a method of PCR with gibrization-fluorescent detection of «Amplisens® *Chlamydia trachomatis*/ *Ureaplasma urealyticum* /*Mycoplasma hominis*-FL». The total volume PCR out amount of a reactionary mix – 30 mkl, including the volume of test of DNA – 10 mkl. The DNA was amplified using the following protocol «AmpliSens - 1»: an initial denaturation (95 °C for 15min), followed by 5 cycles of denaturation (95 °C for 5 s), annealing (60 °C for 20 s) and extension (72° C for 15 s), followed by 40 cycles of denaturation (95 °C for 5 s), annealing (60 °C for 20 s) with a final fluorescence detection and extension (72° C for 15 s). The diagnostic value of a set for detection of microorganisms in concentration more than 10<sup>3</sup> colony constitutive units in 1 ml.

When using sets of reagents for identification of DNA of each microorganism analyze curve accumulation of a fluorescent signal on two channels: - on the channel for a fluorofor of FAM the signal testifying to accumulation of a product of amplification of a fragment of DNA of the revealed microorganism is registered, - on the channel for a fluorofor of JOE the signal testifying to accumulation of a product of amplification of DNA of eternal control sample is registered.

Principle of interpretation of results the following

- DNA of a microorganism is found if for this test in the table of results of the channel for a fluorofor of FAM value of the threshold cycle Ct is defined. Thus the curve of fluorescence of this test has to cross the threshold line on a site of characteristic exponential lifting of fluorescence.
- DNA of a microorganism isn't found if for this test in the table of results of the channel for a fluorofor of FAM it isn't defined there (is) no value of the threshold cycle Ct (the curve of fluorescence doesn't cross the threshold line), and in the table of results of the channel for a fluorofor of JOE the value of the threshold cycle Ct which isn't exceeding specified (boundary) value is defined.

### Statistical analysis

The data were analyzed using criteria Student tests. The results are expressed with calculated standard deviations (SD). We considered  $p$  values of  $\leq 0,05$  to indicate statistical significance.

## Results of researches:

In studied group of women were observed moderated (66, 7±7, 5%), ochroleucous color (68, 5±8, 3%), homogeneous (70, 4±11,2 in %), viscous (70,4±11,2 in %) allocation from sexual ways more often. At survey of mucous membranes of genitals the vagina hyperemia (48, 1±6, 7 %) and uterus necks (59, 3±7, 1 %) more often came to light, and also contact bleeding of a neck of a uterus (50, 0±6,4 by %) was noted. At bimanual survey more often in this group of women morbidity and increase in appendages of a uterus, existence of adhesive process in a small basin (51, 9±6, 6 by % and 70, 4±11, 2 in %, respectively), ( $p<0,05$ ).

Table 1 - Results of a combination bacterial vaginosis with pathogenic and/or opportunistic microorganisms

Infectious agents	Number of patients (N=54)	
	Absolute number	%
Chlamydia trachomatis	32	59,3±7,1
Ureaplasma urealyticum	39	72,2±11,4*
Mycoplasma hominis	26	48,1±6,7
Association bacterial vaginosis with:		
One infectious agent	21	38,9±6,3
Two infectious agents	23	42,6±6,5
Three infectious agents	10	18,5±3,5*
Remarks:* - distinctions are authentic, $p<0,05$		

## Discussion of results:

Apparently from the presented data in table 1, in studied group of women the PCR method and/or a cultural method with a quantitative assessment found Chlamydia trachomatis at 32 (59, 3±7, 1 %) patients, U. urealyticum at 39 (72,2 ±11,4 %) and M. hominis in high titers – at 26 (48,1± 6,7 %). It is revealed that is more often bacterial vaginosis associated with Ureaplasma urealyticum in comparison with Mycoplasma hominis ( $p<0,05$ ).

Only Ureaplasma urealyticum in high titers is found at 8 (14, 8 %) the women, only by Mycoplasma hominis in high titers – at 5 (9,3 %), only Chlamydia trachomatis – at 8 (14,8 %).

Thus, the association bacterial vaginosis with one infectious agent in the studied group of women was observed in 21 (38, 9 ± 6, 3 by %) a case. Association with two infectious agents - at 23 (42, 6 ± 6, 5 the %) patients, from them at 9 (39, 1 %) bacterial vaginosis was combined with Ureaplasma urealyticum and Mycoplasma hominis in high titers, at 12 (52,2 %) with C. trachomatis and U. urealyticum, at 2 (8,7 %) Chlamydia trachomatis and Mycoplasma hominis.

At 10 (18, 5±3, 5 the %) patients observed association bacterial vaginosis with three infectious agents: Chlamydia trachomatis, Ureaplasma urealyticum and Mycoplasma hominis.

It is revealed that associations bacterial vaginosis less often met three infectious agents in comparison with one and two (18, 5±3, 5 %, 38, 9±6,3 %, 42,6±6,5 %, respectively, ( $p<0,05$ ).

To important features of urogenital chlamidiosis, besides its not enough symptoms and high frequency of complications, often meeting association with other STI activators, and also a many loci treats with involvement in pathological process not only urogenital bodies, but also quite often rectum, a throat, eyes, joints, heart, skin.

All 32 patients with the revealed urogenital clamidiosis were surveyed for an exception of a many loci of infectious process. Thus, PCR method Chlamydia trachomatis were found in rectum – at 15 (46, 9±4, 3 by %), in a oropharynx – at 21 (65, 6±7, 5 in %) women.

Thus, Chlamydia trachomatis came to light in the urogenital center (an urethra and the cervical channel) in comparison with chlamydial defeat rectum and oropharynx (98, 4±9, 3 %, 46, 9±4, 3 %, 65,6±7,5 %, respectively), ( $p<0,05$ ) more often.

## Conclusion

Recently often applied method of diagnostics of causative agents of urogenital infections is PCR, allowing identifying them in liquids and organism fabrics. The method is based on the analysis of nucleotide sequence and it is considered the most sensitive (94-100 %) and specific (97-100 %). The main problem in use of PCR is connected with their exclusively high sensitivity of a method that demands observance of rigid rules of work. Besides, at interpretation of results, it is necessary to consider that PCR reveals only a small part of a genome of a microorganism and, therefore, isn't criterion of its viability [13, 14].

We are demonstrated an association between increased severity of BV and the future incidence of contracting an STI. Although the use of the scoring systems used in this article may not be practical in the hospital, the studies' conclusions are most helpful in counseling the patient, as having all more severe cases of BV puts that patient at risk for future STIs.

Thus, bacterial vaginosis now it is necessary to consider not only as frequent independent nozological unit, but also as a background for additional development of STI. In this regard the importance has careful laboratory inspection of each patient bacterial vaginosis on STI, including carrying out screening on existence of the extra genital centers of a chlamydia infection. Attracts attention, what even in the absence of STI, at patient's bacterial vaginosis, besides vagina defeat, signs cervicitis and/or urethritis take place. It can be caused by realization of pathogenic properties of opportunistic microorganisms.

Our study provides support for the interpretation that sexual behavior has a causal role in the development of BV. Whereas this study was not designed to track the transmission of specific microorganisms that might be necessary for the development of BV, the longitudinal design and the data analysis allowed to separately assess three possible causal links: 1) that sexual behavior commonly associated with the acquisition of STIs is also associated with the development of BV; 2) that the acquisition of STIs is a risk factor for the subsequent development of BV; and factor for incident three infectious agents) differed in their associations with the two study outcomes, supporting the hypothesis of a similar etiologic role of sexual behavior in the acquisition of STIs and BV.

Although this study is somewhat limited by both the inherent recall bias of the participants and the recognized fact that young women tend to underreport sexual behaviors, it does add to a growing body of evidence that supports BV as a sexually transmitted illness. Findings are consistent with a causal role of sexual behavior in the acquisition of BV and confirm that BV facilitates acquisition of three infectious agents and vice versa independently from other risk factors. An important note is that Gram staining results are compatible with PCR results, since this method is fast, easy and inexpensive, so that it could be used in developing countries, where and when molecular techniques are not available. The high frequency in Kazakh young women found in this study is alarming, since BV increases woman's susceptibility to HIV, HPV and other important sexually transmitted diseases. Therefore BV has to be correctly and timely diagnosed in order to be adequately treated. Further investigations regarding other pathogens involved in BV such as *A. vaginae* and *Mobiluncus* spp. are warranted.

## Conflict of interest

All authors declare to have no conflict of interest.

## Acknowledgements

The authors would like to thank Dr. Gani Bodykov (Manager of office of gynecology of City clinical hospital No. 4, assistant to chair of Obstetrics and Gynecology No. 2), for providing vaginal samples and demographic data of the patients included in this study.

**References:**

- Colli E, Bertulesi C, Landoni M, Parazzini F. Bacterial vaginosis in pregnancy and preterm birth: evidence from the literature. *J Int Med Res* 1996; 24:317–24.
- Shanon H. Diagnostic microbiology of bacterial vaginosis. *Am J Obstet Gynecol* 1993; 165:1240–4.
- Carey JC, Klebanoff MA, Hauth JC, et al. Metronidazole to prevent preterm delivery in pregnant women with asymptomatic bacterial vaginosis. *N Engl J Med* 2000; 342:534–40.
- Simoes JA, Giraldo PC, Faundes A. Prevalence of cervicovaginal infections during gestation and accuracy of clinical diagnosis. *Infect Dis Obstet Gynecol* 1998; 6:129–33.
- Amsel R, Totten PA, Spiegel CA, Chen KC, Eschenbach D, Holmes KK. Nonspecific vaginitis. Diagnostic criteria and microbial and epidemiologic associations. *Am J Med* 1983; 74:14–22.
- Hillier SL. Diagnostic microbiology of bacterial vaginosis. *Am J Obstet Gynecol* 1993; 169:455–9.
- Nugent RP, Krohn MA, Hillier SL. Reliability of diagnosing bacterial vaginosis is improved by a standardized method of gram stain interpretation. *J Clin Microbiol* 1991; 29:297–301.
- Askarova G. K., Habizhanov A.B., Utegenova A.K., Nurgaliyeva A.M. A comparative assessment of diagnostic sensitivity of laboratory methods in diagnostics of chronic forms of a gonococcus infection//Materials of the International scientific and practical conference “Genomic technologies in medicine and medical education at a turn of centuries”. – Almaty; 2006. – P.-160-161.
- Global strategy for the prevention and control of sexually transmitted infection: 2006-2015: breaking the chain of transmission//*Vestn.Dermatology and venerology*. - 2008. - No. 4. - Page 17-30.
- Centers for Control and Prevention. STD Guidelines, 2006.
- Kisina V. I. Prilepsky B.H., Sokolovsky E.V. etc. Diskutabelnye questions of clinical value of genital mycoplasmas//*Clinical dermatology and venereology*. - 2007. - No. 1. - Page 71-77.
- Centers for Disease Control and Prevention. 1998 Guidelines for treatment of sexually transmitted diseases. *MMWR Recomm Rep*. 1998; 47:1–111.
- Kiselyov V. I., Dmitriev G. A., Latypov M. F. Polymerase chain reaction in diagnostics of urogenital infections. – M, 2000. – P. 166.
- Le Bar W.D. Keeping up with new technology: new approaches to diagnosis of Chlamydia infection // *Clin. Chem*. – 1996. – Vol.42, N.5. – P. 809-812.

# RISK ASSESSMENT OF BENZENE, TOLUENE, ETHYLBENZENE, AND XYLENES (BTEX) IN PAINT PLANTS OF TWO AUTOMOTIVE INDUSTRIES IN IRAN BY USING THE COSHH GUIDELINE

*Aliasghar Farshad, PhD*

*Hamid Khabazi Oliaei, MSc*

Occupational Health Research, Iran University of Medical Sciences, Iran

*Roksana Mirkazemi, PhD*

Hooman Research Collaborators Institute, Tehran, Iran

*Shahnaz Bakand, PhD*

Occupational Health Research, Iran University of Medical Sciences, Iran

---

## Abstract

**Objectives:** The purpose of this study was to assess the risk Benzene, Toluene, Ethylbenzene, and Xylenes in the paint plants of two automotive industries in Iran by using the COSHH guideline and by measuring the ambient concentration of these chemicals.

**Method:** This cross sectional study was conducted in two phases, in phase one the BTEX ambient concentration was measured in three units of paint plants according to the method advised by OSHA12. In the second phase, the COSHH data collection forms were used for a qualitative risk assessment and were distributed among 90 randomly selected workers (45 in each industry).

**Results:** In both industries, maximum risk rating was for benzene followed by toluene, which showed moderate to high risk level for these two chemicals in both industries. Mean ambient concentration of benzene and toluene were 34.9 and 4.4 times of Iranian standard Threshold Limit Value in industry no 1, and 9.5 and 1.9 times of Iranian standard Threshold Limit Value in industry no 2, respectively. The level of concentration of BTEX and the risk rating in industry number 1 was significantly more than that of industry number 2.

**Conclusion:** This study revealed the need for control of Benzene and Toluene in work place, and also showed that the COSHH risk assessment showed a similar result to the actual measuring of the same substances.

---

**Keywords:** Risk assessment, BTEX, COSHH, hazardous substances, ambient concentration

## Introduction:

The production and use of chemicals are increasing worldwide. Output of chemicals increased approximately 10-fold between 1970 and 2010, globally. Exposures to toxic chemicals are one of the main environmental factors contributing to the global burden of diseases. The potential public health risks related to exposure to hazardous chemicals is serious, especially in developing countries, and is magnified by fewer resources for chemical risk management and the projected growth in the production and use of chemicals 1).

Exposure to hazardous chemicals in different industries is the main source of occupational diseases for the workers 2). Exposure to hazardous chemicals in the workplace is not only affected by the mechanical controls, but also by other measures such as administrative and behavioral measures like systems of work, supervision and training. Good measures and practices should be used by employer and employees to control the risk,



minimize the exposure and protect the health of workers and non-workers, who are at risk of exposure.

Control of Substances Hazardous to Health Regulations 2002 (COSHH) was initially used to help duty holders comply with the COSHH regulations in Great Britain 3). COSHH Essentials is a system of workplace risk management for use by proprietors of small and medium sized enterprises 4), and sets basic measures that must be taken by employers, and sometimes employees to ensure controlling exposure to hazardous substances and to prevent adverse effect on health 5), and impose a commitment for the health and safety of employees upon employers. All health authorities should ensure that the highest standards of occupational health are provided 6). This risk assessment includes health, environmental and safety aspects, which enable an appropriate balance between these factors to minimize the exposure to hazardous chemicals 7).

Performance of risk assessment of hazardous chemical is an important process in management of hazards of chemicals. Risk assessment is a process to calculate or estimate the risk of an agent to a targeted organism, system or population following exposure to that agent and includes hazard identification, hazard characterization, exposure assessment, and risk characterization 8). Exposure standards show the ambient concentration of a particular substance or mixture that must not be exceeded 9).

Benzene, toluene, ethylbenzene, and xylenes frequently occur together. These four chemicals are volatile and have good solvent properties. Toxicokinetic studies in humans and animals indicate that these chemicals are well absorbed, distribute to lipid-rich and highly vascular tissues such as the brain, bone marrow, and body fat due to their lipophilicity, and are rapidly eliminated from the body. The available knowledge on toxic or carcinogenic responses to the whole mixtures of BTEX is insufficient. All four components can produce neurological impairment; in addition benzene can cause hematological effects which are associated with aplastic anemia and development of acute myelogenous leukemia. Results of different studies showed that joint neurotoxic action is expected to be additive at BTEX concentrations below approximately 20 ppm of each component. Exposure to relatively high concentrations of BTEX is expected to increase the potential for neurotoxicity and decrease the potential for hematotoxicity/carcinogenicity due to competitive metabolic interactions among the mixture components 10).

The purpose of this study was to assess the risk of hazardous chemicals, BTEX in the paint plants of two automotive industries in Iran by using the COSHH guideline and also by measuring the ambient concentration of these chemicals.

## I.

### Methodology

This cross sectional study was conducted in paint plants of two automotive industries in Iran by using the COSHH guideline and measurement of the actual ambient concentration of these chemicals. The study was conducted in two phases, in phase one the BTEX concentration in the air of 3 units of paint plants (inlet liners, PVC compound and sealer spray and input color) was measured in two automotive industries. In the second phase, the COSHH risk assessment form 11) was distributed among 90 randomly selected workers of painting plant in the two automotive industries (45 in each industry).

In the first phase, measuring the ambient concentration of BTEX was done according to the method advised by OSHA 12). In this method measuring employee exposure to BTEX that represent average 8-hour exposure is determined from a single 8-hour sample. The method was based on absorption of BTEX in an active charcoal tube. Glass Tubes with 6 mm external diameter and 4 mm internal diameter and 70 mm height, containing activated charcoal holder with restrictive Orifice (separated by a 2-mm portion of urethane foam) and sampling universal pump model SKC with low dB were used for sample collection. Both

sides of the tubes were filled with two layers of activated charcoal 20/40 mesh, the front side contained 100 mg and the rear side contained 50 mg activated charcoal. A 3-mm portion of urethane foam was placed between the outlet end of the tube and the back-up section. A plug of silanized glass wool was placed in front of the adsorbing section. The sample was extracted from front side charcoal, and rear side of sorbent tubes was used separately, as control for the emission of the pollutant. The sampling tube was from SKC, USA Company. The sampling pump was calibrated by a rotameter for 40 ml/minute before the study. To measure the real BTEX exposure duration in a shift work long duration, the pump flow was reduced 6 times and the duration of measurement increased to 250 minutes. The sampling number, the pump number, the time of and duration of sampling, the humidity, the wet and dry temperature, and the date of sampling was labeled on each tube. The charcoal in the tube was transferred to a small, stoppered vial, and the analyte was desorbed with 1000  $\mu$ l of carbon disulfide, and was kept for 30 minutes. The extraction and analysing was done before 10 days of sampling. There was a control tube for each sample.

An aliquot of the desorbed sample was injected into a Gas Chromatography (GC) detection. The GC device, equipped with a flame ionization detector (FID), was made in Japan (GC Chrompack CP 9001). The GC device was set on a time schedule of 60°C for two minutes, then increase in temperature 10°C per minute till the temperature reaches to 230°C and set for two minutes at the same temperature, and then the temperature reduced to 60°C. The total run time was around 10 minutes.

Calculating the sample size was based on the correction for pressure and temperature for SKC pump as follow:

$$\text{Sample (ml)} = R * K * (P1/760) * [298 / (T + 273)]$$

R: The observed number on rotameter

K: the calibration coefficient

P1: The air pressure at the time of sampling (mmHg)

T1: The temperature at the time of sampling (°C)

In the second stage the COSHH data collection form was used for a qualitative risk assessment. General information regarding different hazardous substances, demographic information of the workers, the level and routes of exposure, evaluating the hazardous substances controlling system including the engineering and personal controlling systems, the efficacy of safety trainings, the risk and ways of exposure and the medical records of the workers, was elicited by a form which consisted of six sections. Information about work practices and procedures including the type of the job of a worker, the duration of exposure and also the safety training in the industry was collected in the first section. Information related to the hazardous substances resulting from the painting procedure, and the sources of pollution including the existing pollution sources like gases, steam, dust and particles, and the possibility of exposure and routes of exposure was collected in the second section of the data collection form. In the third section, information related to the safety measures like storage, transport, and packaging and labeling of the hazardous chemicals was collected and compared to the standard procedure based on MSDS forms for each chemical that in this article, BTEX are the major concern. Also the emergency kits and equipment at the time of accidents like eye-wash, safety shower and the first aid kits and their work condition was assessed. The fourth section of the questionnaire was related to the industrial controlling measures for the hazardous substances including general ventilation and local exhaust ventilation systems and other personal protective equipment. In this section the efficacy and the maintenance information related to this safety equipment and the result of technical inspection were enquired from the industries. In the fifth section the concentration of hazardous chemicals, resulted from the above mentioned measurement were collected and registered in the data collection form. In the sixth section of the data collection form, the information related to medical care facilities and medical records of the workers were collected.

Based on the above mentioned information, a semi-quantitative hazardous risk assessment for four substances BTEX was done.

#### Measures

Determining the risk level included 5 stages:

Stage 1: Obtaining information about hazardous substances which was collected through the first part of the data collection form

Stage 2: Inspecting workplace and evaluate exposure based on the above mentioned data collection form.

Stage 3: Determining the hazard ratio, which was done based on the information obtained from MSDS.

Stage 4: Determining the exposure ratio which was determined based on the below formula:

$n$  is the number of exposure factors and the exposure indicators are defined in a Likert system of 5 values from 1 which means the lowest exposure to 5 which is the highest exposure.

Stage 5: Determining the Risk Rating (RR)

Based on the above calculated Hazard Rating (HR) and Exposure Rating (ER) and the below formula:

Then, the risk level was determined based on the risk rating, the risk rating 0-1.7 was considered as insignificant, 1.7-2.8 as low, 2.8-3.5 as moderate, 3.5- 4.5 as high and 4.5-5 as very high

#### Data analysis

All analyses were performed using statistical package for social sciences (SPSS) version 16.0 for windows (IBM Corporation, New York, United States) and Mann-Withney U test was used to compare the results in the two industries.

#### Ethical issues

Participants were explained that the data are considered as confidential and their identity will not be revealed and the data will not be used except for the research purpose. All participants gave verbal consent to participate in the study.

#### Results

Table 1 shows the mean BTEX risk rating in the two automotive industries. In both industries, maximum risk rating was for benzene (3.7 and 3.4 respectively) followed by toluene (3.5 and 3.3 respectively), which showed moderate to high risk level for these two chemicals in both industries, however the level of concentration of each BTEX substances in industry number 1 was significantly more than that of industry number 2 ( $P < 0.005$ ).

**Table 1:** Mean risk rating and risk level of BTEX in the painting plants of the tow automotive industries

Hazardous chemicals	Mean risk rating in industry 1	Mean risk level in industry 2	Mean risk rating in industry 2	
Benzene*	3.7 ± 0.2	High	3.4 ± 0.3	Moderate
Toluene*	3.5 ± 0.3	High	3.3 ± 0.3	Moderate
Ethyl-benzene*	2.7 ± 0.4	Low	1.9 ± 0.3	Low
Xylene*	2.6 ± 0.4	Low	2.0 ± 0.3	Low

\* All risk rating was significantly higher in industry number 1 (Mannwitney U test)

The result of measuring the actual concentration of each BTEX substances is shown table 2. Mean ambient concentration of benzene and toluene in both industries was very high and much higher than Iranian standard Threshold Limit Value (TLV) (34.9 and 4.4 times in industry no 1, respectively and 9.5 and 1.9 times in industry no 2, respectively), the level of concentration of BTEX in industry number 1 was significantly more than that of industry number 2 ( $P < 0.005$ ).

**Table 2:** Mean ambient concentration of BTEX and ratio of ambient concentration of BTEX to Iranian standard TLV in the painting plants of the two automotive industries

	Industry no 1		Industry no 2	
	Mean atmospheric concentration (ppm <sup>5</sup> ) ± SD	Ratio of ambient concentration of BTEX to Iranian standard TLV**	Mean atmospheric concentration (ppm) ± SD	Ratio of ambient concentration of BTEX to Iranian standard TLV**
Benzene*	19.9 ± 4.8	34.9	5.4 ± 2.3	9.5
Toluene*	216.7 ± 119.6	4.4	101.9 ± 27.4	1.9
Ethyl-benzene*	75.0 ± 6.4	0.46	68.3 ± 6.5	0.8
Xylene*	39.2 ± 21.1	0.26	13.4 ± 7.8	0.2

\*All ambient concentration was significantly higher in industry number 1 (Mannwitney U test)

\*\* TLV for benzene is equal to 0.5 ppm, toluene is equal to 0.50 ppm, ethyl-benzene is equal to 100 ppm and for Xylene is equal to 100 ppm, Iranian standard.

## Discussion

Assessment and evaluation of the level of risk of hazardous substances to the workers is an incumbent responsibility of employers and health authorities in each industry. A proper system and guideline is needed to help the employer to identify, measure and priorities the risk level of each hazardous substances for each worker in a practical and easy to apply ways. The COSHH provide such a mean for employees to easily assess the situation and control the risk to their employees and others who may be exposed to the risk. This study was an attempt to assess the risk of fours hazardous substances BTEX by using COSHH and actual measurement of the ambient concentration of these substances in two painting plant of two automotive industries in Iran.

This study showed that the level of benzene and toluene in industry number 1 was high and in industry number 2 was moderate. The measurement of ambient concentration of these substances also showed that the mean concentration of benzene was significantly higher in industry number one which is consistence with the risk level and risk rank by using COSHH and showed the strength of COSHH as an easy to apply measure for assessing and prioritizing the risk of hazardous chemicals. The finding of Lee et al. on evaluation of the COSHH Essentials model with a mixture of organic chemicals at a medium-sized paint producer suggested that the COSHH essentials model worked reasonably well for the volatile organic chemicals at the plant, however, it was difficult to override the reproductive hazard even though it was meant to be possible in principle 13). Study of Siriruttanapruk and Burge on the impact of the COSHH regulations on workers with occupational asthma in UK showed that COSHH was successful in increasing awareness of health related risk of hazardous chemicals and training them the required skills to control exposure to hazardous chemicals among employers 14).

This study showed that the concentration of ambient benzene was 19.9 ppm and 5.4 ppm and the concentration of ambient toluene was 216.7 ppm and 101.9 ppm in two industries, respectively, which is a very high concentration. In a study in Thailand the mean concentration of benzene was 92.7 ppb, toluene 195.3 ppb, Ethyl benzene 6.25 ppb and xylene 11.6 ppb, in gas stations. The study in Thailand, showed that exposure to this amount of benzene and toluene was significantly associated with fatigue, and also, the mean lifetime cancer risks for workers exposed to this concentration of benzene and ethylbenzene for 30 years were estimated at  $1.75 \times 10^{-4}$  and  $9.55 \times 10^{-7}$  15). Therefore, exposure to the higher level of benzene and toluene in this study can raise a much higher risk of cancer for the workers on these two industries.

A study by Chaudhary and Kumar in Firouz Abad India, which monitored BTEX concentrations in ambient air showed that the mean concentration of benzene (ranging from 0.197 ppm to 0.207 ppm), toluene (0.198 ppm to 0.209 ppm), ethyl benzene (0.195 ppm to

<sup>5</sup> 1ppm = 1000ppb

0.285 ppm) and xylene (0.195 ppm to 0.205 ppm) and the BTEX concentrations ranged from 0.0127 ppm to 0.013 ppm in industrial areas and 0.675 ppm to 0.784 ppm in refueling pump station, which is much lowered from concentration of these chemicals in this study 16).

In a study on BTEX personal exposure monitoring in four Australian cities, it was shown that the level of exposure of the usual citizens to these four chemicals was much below the standard and the most elevated exposure measurement recorded for each of the BTEX constituents was; 23.8 ppb for benzene, 2120 ppb for toluene, 119 ppb for ethylbenzene and 697 ppb for xylene, respectively, and also it was shown that the elevated concentrations were associated with non-occupational activities such as the use of lacquer thinners, resins and house paints and exposure to spilt petrol 17). The level of exposure of citizens in these four main Australian cities was nearly 1000 times less than the level of exposure of the workers in these two industries.

This study showed that the level of benzene and toluene was 35 and 4.4 times, and 9.5 and 1.9 times more than TLV Iranian standard in the two industries, respectively. In a study on a sample of 8 Italian handicraft car painting shops, the exposure levels to solvents, was measured using three classic exposure monitoring methods, namely environmental sampling with charcoal tubes, personal sampling with diffusive charcoal samplers, and urinary determination of unmetabolised solvents and the result of this study showed that benzene was found in all shops, at levels around or higher than the 8-h time-weighted average limit (8-h TLV-TWA) 18).

The best way to control the risk of BTEX is to reduce the exposure to the emission of these chemicals in the ambient air of the working place, which can be done by using protective equipment and using proper respiratory masks. This study showed that 77.8% of exposure to BTEX was respiratory and skin exposure, which should be controlled via using personal protecting equipment like respiratory masks, proper clothing and gloves. Garrod and Rajan-Sithamparamanadarajah explained COSHH can simply be adapted to produce specific control advice, but where it is not possible or practical to use control advice, the control bands of COSHH can suggest adequate respiratory protective equipment using 'protection factors' 19).

The low number of sampling unites and measuring the ambient concentration in a short duration of time were the study limitations which may have distorted the accuracy of results in term of its magnitude.

### **Conclusion:**

This study revealed the urgent need for control of hazardous substances of Benzene and Toluene in work place, and also showed that the COSHH evaluation of risk of hazardous substance showed a similar result to actual measuring of the same substances, which is much more complicated and costly.

### **References:**

- World Health Organization. Human Health Risk Assessment Toolkit: Chemical Hazards..[online]. 2010 [cited 2012 Dec 7]; Available from: URL:[http://www.who.int/ipcs/methods/harmonization/areas/ra\\_toolkit/en/index.html](http://www.who.int/ipcs/methods/harmonization/areas/ra_toolkit/en/index.html)
- Tse SW, Lai G. A review of COSHH essentials. *Process Saf Environ* 2002; 80(4): 177-80.
- Garrod AN, Evans PG, Davy CW. Risk management measures for chemicals: the "COSHH essentials" approach. *J Expo Sci Environ Epidemiol* 2007; 17 Suppl 1: S48-54. Epub 2007 Jun 13.
- Rachael M, Jones N, Mark N. Evaluation of COSHH Essentials for Vapor Degreasing and Bag Filling Operations. *Ann Occup Hyg* 2006; 50(2): 137-147.
- Health and Safety Executive. COSHH: A brief guide to the Regulations What you need to know about the Control of Substances Hazardous to Health Regulations 2002 (COSHH).

- [online]. 2002 [cited 2012 Dec 1]; Available from: URL: <http://www.materials.ox.ac.uk/uploads/file/COSHHRegulations.pdf>
- Waldron HA. COSHH and the NHS. *Br J Ind Med* 1989; 46: 753-754.
- Safe Work Australia. Managing Risks of Hazardous Chemicals in the Workplace. [online]. 2012 [cited 2012 Dec 2]; Available from: URL: <http://creativecommons.org/licenses/by-nc/3.0/au/>
- Maazza YAM. Risk assessment of hazardous chemicals - a case study in chemistry research laboratories of USM [Master of science degree Thesis]2008. Available from: URL: [http://eprints.usm.my/10354/1/RISK\\_ASSESSMENT\\_OF\\_HAZARDOUS\\_CHEMICALS.pdf](http://eprints.usm.my/10354/1/RISK_ASSESSMENT_OF_HAZARDOUS_CHEMICALS.pdf)
- Safe Work Australia. Guidance on the Interpretation of Workplace Exposure Standards for Airborne Contaminants. [online]. 2012 [cited 2012 Dec 2]; Available from: URL:<http://www.safeworkaustralia.gov.au/sites/swa/about/publications/pages/interpretation-airborne-contaminants-guide>
- U.S. Department of Health and Human Services Public. Interaction Profile For: Benzene, Toluene, Ethylbenzene, and Xylenes (BTEX). [online]. 2004 [cited 2012 Dec 2]; Available from: URL: <http://www.atsdr.cdc.gov/interactionprofiles/ip-btex/ip05.pdf>
- Safe Work Australia. NOHSC: 3017, The guidance of risk assessment result of hazardous chemical in workplace for health of employers. [online]. 1994 [cited 2012 Dec 2]; Available from: URL: <http://www.safeworkaustralia.gov.au/sites/SWA>
- Occupational safety and health administration: Sampling and analytical methods for Benzene monitoring and measurement procedures; p 1910.1028.
- Eun G L, James S, Russell B, Bowen H, Martin H. Evaluation of the COSHH Essentials Model with a Mixture of Organic Chemicals at a Medium-Sized Paint Producer. *Ann Occup Hyg* 2011; 55(1): 16–29.
- Siriruttanapruk S, Burge PS. The impact of the COSHH regulations on workers with occupational asthma. *Ocaip Mad* 1997; 47(2): 101-104.
- Tunsaringkarn T, Siriwong W, Rungsiyothin A, Nopparatbundit S. Occupational Exposure of Gasoline Station Workers to BTEX Compounds in Bangkok, Thailand. *Int J Occup Environ Med* 2012; 3:117-25.
- Sandhya C, Ashok K. Monitoring of Benzene, Toluene, Ethylbenzene and Xylene (BTEX) Concentrations in Ambient Air in Firozabad, India. *Int Arch Appli Sci Techno* 2012; 3(2): 92 - 96.
- Department of the Environment and Heritage, Australia. BTEX Personal Exposure Monitoring in Four Australian Cities, Technical Report No. 6. [online].2003 [cited 2012 Dec 2]; Available from: URL: <http://www.environment.gov.au/atmosphere/airquality/publications/report6/pubs/report6.pdf>
- Matteo V, Francesca E, Daniela S. Exposure to organic solvents among handicraft car painters: a pilot study in Italy. *Ind Health* 2006; 44: 310-17.
- Garrod ANI, Rajan-Sithamparamanadarajah R.. Developing COSHH Essentials: Dermal Exposure, Personal Protective Equipment and First Aid. *Ann occup Hyg* 2003; 47( 7577–588.

# VEGETATIVE CORRELATES OF COGNITIVE PROCESSES IN STRESS SITUATION

*Anastasya V. Bakhchina, graduate student*

*Sophya A. Polevaya, doctor of biology*

*Sergey B. Parin, doctor of biology*

Nizhny Novgorod state University named N.I. Lobachevsky,  
Department of psychophysiology, Russia

---

## Abstract

In this series of experiments we investigated the relationship between the structure of the behavioral activity of a person in a virtual computer environment, and the structure of physiological reactions in the context of legitimate and random dynamics of informative images. In the experiments was implemented the technology of integrated monitoring of the functional state and event of context in conditions of a natural human activity in a virtual computer environment.

AIM: To study of autonomous components of a functional system, providing purposeful behavior of the person in stress information contexts.

METHODS: Sixty healthy subjects and fifty addicted patients (age or gender difference is not taken into account) participated in the study. Heart rate measurement was performed with the help of the system of the telemetry wireless registration of the heart rhythm. During the experiment we recorded face of the subject and the content of his computer screen.

CONCLUSION: The operational management of heart rhythm is agreed with the level of uncertainty of information image.

---

**Keywords:** Stress, autonomic regulation, cognition functions, emotion state

## Introduction:

The relevance of this work is determined by the high social importance of the research devoted to the development of knowledge about the dynamics of human functional state in the conditions of daily life. In today's reality, most human diseases are the results of excessive loads of different nature. The major problem is the search for methods of early detection of dangerous status in order to prevent the risks of health disorders. Therefore, questions about the presence of markers of excessive arousal, resource depletion, energy depletion, stress are very important.

The stress is the most wasteful mode for the body. The reaction of stress is a non-specific systemic defensive reaction to the damage or its threat. The factor of the launch of this reaction is an information parameter. This information parameter is the signal of excessive disagreement of two images: the current and required ones. Based on the theory of functional systems by P.K. Anokhin, stress factors can be divided in the dependence of the functional systems block, which includes disagreement: informational factor; physical factor; affective factor. Thus, the task of finding specific for different functional states markers include monitoring of all the variables that are involved in the formation of the state, exogenous context (object environment and its dynamics), endogenous context (status options «up» and their dynamics). Still in the research practice, the functional state of the person is assessed by measurement in laboratory conditions, which includes hard monitoring of the status of the subject (while sitting or lying) and the absence of external stimulus. However,

this approach greatly narrows the range of techniques, because management modes of the physiological system of the person are associated with the target function and vary widely in accordance with the meaningful context. The studies of physiological signals in laboratory conditions don't allow to predict the characteristics of physiological reactions in the conditions of daily life.

According to modern notions, autonomic regulation of heart rate reflects the activation level and voltage systems of the body. The experience of the studies of 1960-s regarding HRV as a set of characteristics of the system of regulation demonstrates the sensitivity of this parameter to any changes in mental or physiological states of the living object, which is consistent with the original idea of neocortex-heart links by Claude Bernard. This fact is confirmed by empirical studies devoted to the measurement of HRV in the contexts of information, physical and integral loads [Taelman et al., 2011] and targeted researches of the linkage parameters of HRV with the activity of various neuronal structures using the method of neuroimaging (fMRI, PET) [Critchley, 2003; Whalen et al., 2004; Holland and Gallagher, 2004; Gianaros, 2004; Belova et al., 2007; Napadow et al., 2008; Johnson et al., 2009; Whalen and Phelps, 2009; Lane, 2009; Ahs et al., 2009; Ruiz-Padial et al., 2011]. Modern studies provide a broad base of results of measurement of HRV in different groups of subjects: patients with depressive disorders, postinsult patients, suffering from diabetes and other disorders [Hanson, 2001; Collins et al., 2005; Melillo et al., 2005; Samen et al., 2007; Chandola et al., 2008] and under different experimental laboratory contexts: fatigue, overexertion, different types of stress: an examination, work, etc. [Carney et al., 2009; Nikolova et al., 2007,2011; Taylor et al., 2009,2011]. Thus, we can make a conclusion about the non-specificity of changes of HRV under the influence of exogenous and endogenous factors, which confirms the hypothesis of informative markers of stress (nonspecific reaction of the organism) in the dynamics of HRV.

The development of methods for mathematical processing of cardiointervalogramme led to the discovery of a large number of indicators (statistical, geometrical, frequency), which, on the one hand, are closely correlated with each other, making the entire set excess, and on the other one - suitable for interpretation and evaluation of cardio-signal in stationary conditions.

The influence of activity of the stress-regulatory systems (sympathoadrenal (SAS), hypothalamic-pituitary-adrenal (HPA), the endogenous opioid (EOS)) on the vegetative regulation of cardiac rhythm was investigated independently, i.e. there are separately shown the effects of activation SAS, HPA, EOS in the dynamics of HRV [Lishmanov et al, 1995; Maslov et al, 1995; Ardashev et al, 1995; Kus et al., 1995; Chao et al., 1999; Huangetal, 2008; Yehetal, 2008; Coruzzi et al., 2003]. Knowledge about identification of the signs of sequential change of dominance and joint impact of these systems on the dynamics of the autonomic regulation extremely is limited.

Therefore, it is important to use instrumental methods of registration of biophysical signals, providing personalized monitoring and remote diagnostics without restrictions on the length of the recording, distance to the signal source and mobility, the development of non-linear non-stationary methods of mathematical treatment of signals corresponding to the real natural activities in diverse stimulus environment, research of dynamic characteristics of participation stress regulatory systems in the regulation of a cardiac rhythm.

## I.

The time sequence of sensory signals activates imprint of real events with complex cognitive, vegetative, motor and emotional components in the memory of a man ensuring the optimization of life in the real physical environment. It is obvious that the information images as well as the real objects are able to induce physiological reactions, but these reactions are deprived of the biological viability for acting in virtual computer environment. In this series



of experiments we investigated the relationship between the structure of the behavioral activity of a person virtual computer environment, and structure of physiological reactions in the context of legitimate and random dynamics of informative images. In the experiments were implemented using the technology of integrated monitoring of the functional state and event of context in conditions of a natural human activity in a virtual computer environment [Polevaya et al., 2013].

The estimation of biological activity of information images was conducted in three virtual contexts of different degree of complexity: 1. The elementary information context; 2. The complex dynamic informational context; 3. The context of elementary cognitive loads. The data array included the written sequence of R-R intervals, the video of the man's face in various information contexts, a video monitor showing the dynamics of the information images in a virtual computer environment for each subject. On the basis of the tracks of video surveillance there were developed individual chronogram events in virtual reality.

In the elementary information context, there was found a direct relationship between the level of uncertainty of information image and the level of disorganization of the heart rhythm. The indicator of disorganization of the heart rhythm (RRmax-RRmin) was significantly higher in the context of uncertainty compared with a context of clarity ( $p < 0,05$ ). Found effects can be associated with the activity of the operational management of heart rhythm (cortical circuit regulation), consistent with the level of uncertainty of information image.

In most participants (86%) of the research there was observed a mobilizing action of discordance and error management of information images, manifested in the increase of sympathetic activation - sharp increase in the power of oscillations in low-frequency (LF) (1 phase of stress) in the context of computer games (the complex dynamic informational context). Transition physiological system in high-energy mode supports protective reactions in extreme situations with the threat to life. Sympathetic activation in this context devoids of biological viability and leads to the unjustified reduction of the physiological system.

The dynamics of HRV during functional testing ensuring the mainstreaming of a primary cognitive functions and measurement errors motor displaying elementary sensory signals was investigated in the two groups of subjects (healthy, drug-addicts). The analysis of variance showed the presence of the factor (cognitive tests) on HRV parameters ( $p < 0,01$ ). Evaluation results showed that the autonomic provision of cognitive function has the property of adaptability: the modes of HRV are specific to the nature of the cognitive load. The suppression of the regulatory function of the EOS reduces the adaptability of the autonomic regulation (Fig.1.).

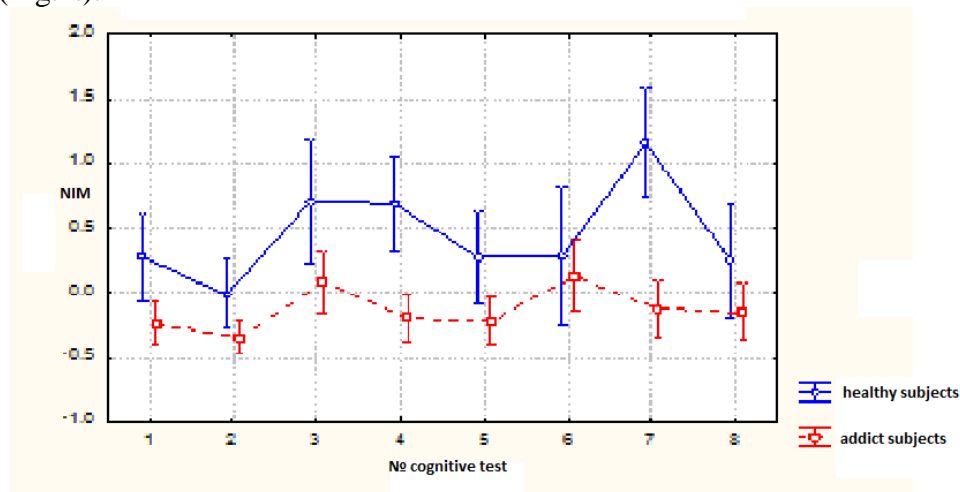

Fig.1. The dynamics of parameters of HRV in 8 cognitive samples in the two groups.

**Conclusion:**

The analysis of the average and personalized dynamics of autonomic functions in natural contexts of activities revealed that:

1. Wireless technology for registration of heart rate-based miniature sensory platforms minimizes the risks of violation of the integrity of the functional system of a person while measuring in the context of the objective function;
2. The Fourier transform with sliding window allows to assess the rapid changes in the mode of autonomic regulation, which is coordinated with time scale of dynamics of information images of the events of the context;
3. The operational management of heart rhythm is consistent with the level of uncertainty of the image information.

**References:**

- Carney RM, Freedland KE. Depression and heart rate variability in patients with coronary heart disease. *Cleve Clin J Med*. 2009. - №76 - P.13–17
- Davidson R.J. Anxiety and affective style: role of pre-frontal cortex and amygdala. *Biol Psychiatry*, 2002, V. 51, No 1, p. 68-80.
- E. Toledo, I.Pinhas, D. Aravot, S. Akselrod *Med. Biol. Eng. Comput.*, 2003, 41,432-438
- Mark A. Staal *Stress, cognition, and human performance: A literature review and conceptual framework – Ames Research Center, Moffett Field, California – 2004. – P. – 169.*
- Shuberta C., Lamtbertz M., Nelesen R.A., Bardwell W., Choid J.B., Dimsdale J.E. Effects of stress on heart rate complexity—A comparison between short-term and chronic stress - *Biol Psychol*. 2009 March ; 80(3): 325–332.
- Taylor G.J. Depression, heart rate related variables and cardiovascular disease. *Int J Psychophysiol*. 2010;78:80–88
- Thayer J.F., Åhs F., Fredrikson M., Sollers J.J., Wager T.D. A meta-analysis of heart rate variability and neuroimaging studies: Implications for heart rate variability as a marker of stress and health - *Neuroscience and Biobehavioral Re-views* 36 - 2012., P. 747–756.

# COMBINED TELMISARTAN / HYDROCHLORTHIAZIDE THERAPY OF THE PATIENTS WITH ESSENTIAL HYPERTENSION AND ASSOCIATED ATHEROSCLEROSIS OF THE LOWER EXTREMITIES' MAIN ARTERIES

*Nadiya Yarema, MD, PhD*  
*Viktoriya Bilochytska*

State Higher Educational Institution "I.Ya.Horbachevsky Ternopil State Medical University,  
Ministry of Public Health of Ukraine", Ternopil, Ukraine

---

## Abstract

Telmisartan/hydrochlorothiazide combined antihypertensive effect on 96 patients with arterial hypertension and associated atherosclerosis has been studied. Telmisartan has been found to reduce arterial pressure gradually, alongside with maintaining stable daily indices and improving both central and peripheral hemodynamics.

---

**Keywords:** Telmisartan, hydrochlorothiazide, arterial hypertension, atherosclerosis

## Introduction

Arterial hypertension (AH) is a crucial problem of the current cardiology. Apart from deteriorating the life quality per se, it triggers the cascade of pathological changes in the heart, vessels, kidneys, and retina as well as in the peripheral arteries and other organs and tissues. This leads to the development of a whole number of maladies and pathological conditions, provokes complications and dramatic mortality increase. Thus AH, by triggering the development and aggravation of major cardiologic pathologies, is of primary importance in the so-called cardio-vascular continuum [1, 2, 5].

According to a series of prospective studies, patients with the diastolic arterial pressure above 105 mm Hg compared to those with the one below 80 mm Hg, are at 10 times higher risk of the cerebral stroke and 5 times higher risk of ischemic disease [2, 4]. VALUE findings convincingly prove that minor difference in the arterial pressure level results in grave disturbances of the cardio-vascular circulation. It concerns the pressure drop or jump in patients with multifactor atherosclerotic damage to main arteries following the administration of antihypertensive drugs. This inadequate antihypertensive therapy results in the increased number of main arteries' thromboses, myocardial infarctions and strokes in the mentioned patient category.

The inhibitors of angiotensin-converting enzyme (IACE) and angiotensin II receptor blockers (ARB II) are rightfully regarded as optimal choice for the continuous treatment of the patients with arterial hypertension and multifactor atherosclerotic damage to main arteries [4, 7]. According to investigation findings, telmisartan – the last-generation angiotensin II receptor blocker – may be the drug of choice for the therapy of the patients with arterial hypertension and atherosclerotic damage to main arteries. Particularly, the antihypertensive effect of telmisartan (80 mg/day) is superior to that of valsartan or losartan in comparable dosage, since it maintains stable arterial pressure through 24 hours, diminishes cellular proliferation, inflammation and oxidative stress. Atherogenesis suppression is the ultimate realization of telmisartan effect [1, 6].

**Objective:** to determine combined telmisartan/hydrochlorothiazide effect on the patients with hypertension and associated atherosclerosis of lower extremities' main arteries.

### Materials and methods

Altogether 96 patients with hypertension and associated occlusion of lower extremities' main arteries were under observation, 57 (59.4%) of them having Stage 2 AH and 39 (40.6%) – Stage 3 AH. The group under observation included 77 men (80.2%) and 19 women (19.8%); the mean age was  $63 \pm 0.9$  years. All cases were diagnosed according to the European Hypertension Society (EHS, 2010) criteria. Exception criteria were secondary AH, Stage 3 hypertension, ischemic cardiac disease (ICD), significant abnormalities of the cardiac rhythm and conductivity, Grade III-IV cardiac insufficiency (NYHA criteria), renal and hepatic failure, exacerbated chronic pulmonary and digestive diseases, malignant, autoimmune and endocrine diseases, gross obesity (body weight index over  $40 \text{ kg/m}^2$ ) and alcohol addiction. Daily arterial pressure (AP) monitoring was performed with the “Holter AP measurement system AVR-01” device. AP was taken at 15 minutes' intervals within 6 a.m. – 11 p.m. and every 30 minutes at nighttime (11 p.m. – 6 a.m.)

Structural and functional characteristics of the left ventricle and its myocardium mass were determined by two-dimensional echocardioscopic Doppler graphic investigation with the Siemens “Sonoline Versa Pro” device. Standard procedure with the use of 3.5 MHz sensor was applied. Among the indices determined were the size of the left atrium (LA), end-diastolic (EDS) plus end-systolic (ESS) sizes of the left ventricle (LV), thickness of the interventricular septum (TIVS) and that of the left ventricle posterior wall (TLVPW). End-diastolic volume (EDV) plus end-systolic left ventricular volume (ESV) as well as left ventricular output function (LVOF) were calculated by standard formulae (Teicholtz formula). Left ventricular myocardium mass (LVMM) and left ventricular myocardium mass index (LVMMI) were calculated by Penn-Convention procedure. The body surface area was calculated by standard tables and Du Bois formula. The state of the central and peripheral hemodynamics was determined with the use of automated rheocardiogram analysis program complex USRG – 01 “CARDIO”. Stroke volume (SV), stroke index (SI), minute blood flow volume (MBFV), general peripheral vascular resistance (GPVR), specific peripheral vascular resistance (SPVR), pulsation index (PI), resistance index (RI), linear circulation velocity (LCV) and volume circulation velocity (VCV) were analyzed. To confirm atherosclerotic damage to the main arteries of lower extremities, the ultrasound study of the arteries with ESAOTE Megas CVX apparatus was performed. Linear format sensors with the ultrasonic radiation frequency of 5-15 MHz were used.

### Results and Discussion

In all cases, AH therapy commenced of telmisartan (80 mg/day). This was followed by the variation analysis of systolic blood pressure (SBP) and diastolic blood pressure (DBP) as well as of average daily SBP and DBP, cardiac rhythm (CR), central and peripheral hemodynamics data on the 10<sup>th</sup>, 20<sup>th</sup>, 30<sup>th</sup>, 60<sup>th</sup> and 90<sup>th</sup> day. In case of insufficient antihypertensive effect, telmisartan dosage was corrected or, if need be, it was supplemented with hydrochlorothiazide (12.5 mg).

Telmisartan monotherapy was administered in 36 cases and telmisartan/hydrochlorothiazide combination – in 60 patients.

Arterial pressure (AP) dynamics analysis revealed insignificant SBP (2.7%) and DBP (3.1%) reduction on the 10<sup>th</sup> day of telmisartan therapy in fixed dosage. The 30<sup>th</sup> day observation findings revealed 10.2 % (SBP) and 9.5% (DBP) reliable reduction. Two months after the therapy commencement, SBP was reduced by 13.7% and DBP – by 16.3%. Stabilization of SBP and DBP indices ( $142 \pm 1.4$  mm Hg and  $86.2 \pm 1.5$  mm Hg respectively, CR -  $74.5 \pm 2.0$  beats/min) occurred after three months' therapy course.

Telmisartan/hydrochlorothiazide combination revealed 5.7% and 7.3% reduction of SBP and DBP respectively on the 10<sup>th</sup> day of the therapy; 10.4% and 11.8% - on the 30<sup>th</sup> observation day; 15.3% and 19.5% - two months after therapy commencement; 18.3% and 22.5% - in three months. On the 90<sup>th</sup> observation day, the AP indices became stable (140.1±1.4 mm Hg and 82.9±1.1 mm Hg for SBP and DBP respectively, CR approximating 75.1±1.1 beats/min). It follows from the above that telmisartan/ hydrochlorothiazide combination in fixed dosage provides gradual and reliable reduction of SBP and DBP indices.

Daily monitoring data following the referred above antihypertensive therapy are produced in Table 1. Analysis of the daily AP monitoring at the initial examination indicates persistent average daily SBP and DBP increase. As compared with pre-therapy values, three months' telmisartan course resulted in average daily SBP and DBP reduction by 21.2% (p<0.05) and 21.6% (p<0.05) respectively. Equally reliable was the dynamics of average day SBP and DBP reduction (23.3% and 22.4% respectively) and of average night one (22.8% and 20.4% respectively).

Table 1 Dynamics of daily AP monitoring indices as affected by antihypertensive therapy in patients with AH and associated lower extremities' occlusive disease

Index	Telmisartan (n=36)			Telmisartan/Hydrochlorothiazide combination (n=60)		
	Prior to therapy	30 <sup>th</sup> day	90 <sup>th</sup> day	Prior to therapy	30 <sup>th</sup> day	90 <sup>th</sup> day
Average daily SBP mm Hg	173,1±2,1	158,3±2,2*	136,4±1,9*	173,4±2,2	155,1±1,5*	134,4±1,8*
Average daily DBP mm Hg	105,1±1,5	90,9±1,3*	82,4±1,3*	105,4±1,5	90,1±1,1*	82,4±1,1*
Average daily CR per minute	88,5±3,8	79,3±2,9	75,3±1,5	87,7±2,8	82,2±2,4	78,1±1,5
Average day SBP mm Hg	170,6±1,3	150,6±1,7*	130,3±1,2*	170,2±1,3	148,4±1,4*	128,1±1,1*
Average day DBP mm Hg	106,3±1,4	96,2±1,6*	82,5±1,54*	105,3±1,4	92,1±1,4*	79,8±1,2*
Average daily CR per minute	89,7±2,7	83,3±2,4	78,7±1,5	89,3±3,7	84,1±2,1	77,9±2,1
Average night SBP mm Hg	157,8±1,4	145,6±1,8*	121,9±1,3*	159,6±1,4	141,3±1,4*	125,8±0,9*
Average night DBP mm Hg	105,1±2,0	89,7±2,1*	83,7±1,5*	107,1±2,0	86,3±1,1*	84,8±1,1*
Average night CR per minute	81,2±2,5	76,1±2,3	70,3±1,9	81,2±2,5	74,4±2,3	69,3±1,4

Note: \* - index difference is reliable in comparison with the data prior to therapy

Three months' combined telmisartan/hydrochlorothiazide therapy provided reliable average daily SBP and DBP reduction by 22.5% and 21.8% respectively. Reduction dynamics of average day SBP and DBP was 24.7% and 24.2% respectively (p<0.05) while that of average night – 21.2% and 20.8% (p<0.05). Three months' antihypertensive telmisartan monotherapy and combined telmisartan/hydrochlorothiazide therapy have been found to provide continuous daily AP reduction including early morning, when the hazard of cardiovascular cases is at its peak due to the elevated AP.

As to the changes of the intracardiac hemodynamics, echocardiographic findings revealed reliable reduction of the end-diastolic volume (EDV) by 18% as compared with pre-treatment data (Table 2). In addition, considerable decrease of general peripheral vascular resistance (GPVR) and specific peripheral vascular resistance (SPVR) was found after 3 months' therapy course.

Table 2 Hemodynamic changes under the influence of antihypertensive therapy in patients with AH and associated lower extremities' occlusive disease

Index	Telmisartan (n=36)		Telmisartan/Hydrochlorothiazide combination (n=60)	
	Prior to therapy	After 3 months' therapy	Prior to therapy	After 3 months' therapy
EDV, ml	147,4±3,1	134,5±2,2*	149,1±2,1	131,4±1,8*
ESV, ml	69,7±2,4	63,4±1,9	70,5±3,8	62,8±3,5
LVOF, %	53,6±1,4	56,3±1,3	52,1±1,4	55,3±2,4
TLVPW, cm	1,2±0,2	1,2±0,1	1,2±0,2	1,1±0,1
TIVS, cm	1,2±0,2	1,1±0,1	1,2±0,2	1,1±0,1
LVMMI, g	183,1±5,9	175,4±3,8	183,4±3,3	174,0±2,9
LVMMI, g/m <sup>2</sup>	91,4±1,9	88,3±2,4	90,3±1,7	84,2±1,4*
GPVR, kPa×s/l	153,2±7,2	104,7±6,1*	149,1±5,4	101,9±6,3*
SPVR, kPa×s/(l×m <sup>2</sup> )	111,4±4,6	84,1±4,2*	109,4±2,4	89,9±5,9*

Note: \* - index difference is reliable in comparison with the data prior to therapy

Combined telmisartan/hydrochlorothiazide therapy provided reliable EDV (by 11.9%) and LVMMI (by 6.8 %) reduction. Considerable decrease of GPVR and SPVR was found. Due to telmisartan/hydrochlorothiazide therapy, positive tendency to LVMMI reduction, LVOF increase as well as TLVPW and LVOF decrease was noticed.

Antihypertensive telmisartan monotherapy and combined telmisartan/hydrochlorothiazide therapy have been found to influence peripheral hemodynamics indices positively (Table 3). Particularly, three months' telmisartan therapy provided reliable PI increase by 11.6%. LCV and VCV increased by 17.8% and 14.3% respectively whereas RI reduced by 11.1%.

Table 3 Dynamics of peripheral hemodynamics indices under the influence of antihypertensive therapy in patients with AH and associated lower extremities' occlusive disease

Index	Telmisartan (n=36)		Telmisartan/Hydrochlorothiazide combination (n=60)	
	Initial	After 3 months' therapy	Initial	After 3 months' therapy
PI, conventional unit	2,26±0,09	2,52±0,08*	2,36±0,05	2,70±0,06*
RI, l/min/m <sup>2</sup>	0,73±0,01	0,65±0,01*	0,69±0,01	0,60±0,01*
LCV, cm/s	0,18±0,01	0,21±0,01*	0,21±0,01	0,25±0,01*
VCV, ml/min	4,73±0,25	5,41±0,22*	4,96±0,23	5,84±0,24*

Note: \* - index difference is reliable in comparison with the data prior to therapy

Telmisartan/hydrochlorothiazide combined therapy has been found to provide reliable increase of PI by 14.2%, LCV – by 18.1% and VCV- 17.8% whereas RI reduced by 13.0%.

## Conclusion

1. Telmisartan provides continuous 24-hours' AP reduction including early morning, when cardio-vascular hazards are at their peak due to the elevated AP.

2. As efficient antihypertensive agents as well as central and peripheral hemodynamics improvers, telmisartan alone and telmisartan/hydrochlorothiazide combination may be regarded as the drugs of choice in the treatment of patients with AH and associated atherosclerotic damage to the main arteries of lower extremities.

## References:

European Recommendations on the Management of Arterial Hypertension (2010) // Arterial Hypertension. - №1. (9). – P.17-23.

Russian Medical Society on Arterial Hypertension (RMSAH), All-Russian Scientific Society of Cardiologists (ARSC). Diagnostics and Treatment of Arterial Hypertension. Russian Recommendations (fourth revision). – 2010.

Svyshchenko E.P. Essential Hypertension: Urgency and Solution Prospects in the Current Century // Health of Ukraine. – 2007. – № 12/1. – P. 39-40.

Podzolkov V.I., Tarzimanova A.I. Telmisartan in the Treatment of Arterial Hypertension. Clinical Discussion // Rational Pharmacotherapy in Cardiology. – 2008. - №8 (2). – P.201-204.

Chazova I.E., Ratova L.G., Boytsov S.A., Nebieridze D.V. // Diagnostics and Treatment of Arterial Hypertension (Recommendations of the Russian Medical Society on Arterial Hypertension and the All-Russian Scientific Society of Cardiologists). Systemic Hypertensions. – 2010. – №3. – P. 5-26.

Baguet J-P., Ormezzano O., Barone-Rochette G. Impact of Telmisartan in Modifying Vascular Risk // Integrated Blood Pressure Control. – 2010. – Vol.3. – P. 81-89.

Kurtz T., Klein U., Next Generation Multifunctional Angiotensin Receptor Blockers. Hypertens Res 2009; 32 (10): 826-34.

# INFLUENCE OF BUILDING FORM OF HOSPITAL ON ITS ENERGY PERFORMANCE

*Vladyslav Shchuchenko, M.Sc., PhD fellow*

Telemark University College, Norconsult, Norway

*Bernt Lie, PhD, Prof.*

Telemark University College, Norway

*Trond Thorgeir Harsem, M.Sc, Associate Prof.*

Norconsult, Oslo and Akershus University College, Norway

---

## Abstract

In this study thermal performance of hospital buildings with various geometries is examined.

The aim of the work is to study the impact of the hospital building geometry on the total energy consumption. Three types of buildings are investigated – an arcade with glazed roof, a pavilion and a tower on a base (or in some literature called "matchbox on a muffin"). These hospital geometries (with some degree of deviation) are most commonly used in healthcare.

The hospital geometries were simulated in several steps: beginning from existing (base case) hospital and further applying energy measures to achieve low energy hospital (with better insulated building body and demand controlled ventilation and lighting). The latter type is in its emerging phase and will be more and more in focus as authorities implement stricter building codes and as the demand on energy effective buildings rises continuously.

The area of the modeled hospital is about 96 500 m<sup>2</sup>. The model represents an "average" large university hospital in Norway. Occupancy, schedule, internal gains, ventilation rates and fabric data are kept constant for each of the simulated cases. Influence of the hospital geometry in moderate and polar climate were also investigated.

Building envelope data and technical systems data have been varied during the simulation in order to see how big influence has geometry on existing and low energy hospitals.

Building models are simulated using Simien building energy and indoor climate software [1].

The results of this study show that, in general, geometry of the hospital building has very little influence on its energy use.

---

**Keywords:** Building form, hospital, energy

## Introduction:

While building sector is responsible for about 40 % of energy use [2], hospitals represent ca. 6 % of the total energy consumption in the public building sector [3]. Hospitals are one of the most energy intensive building categories. A hospital uses 2.5 times more energy than a similar sized office building [4].

Breakdown of the energy flows in hospital is shown in Figure 1. The "Other" category in this Figure represents electricity consumption by medical and office equipment.



All hospitals are unique in shape and size and also in services they provide. This study focuses on large university hospitals, such as e.g. Rikshospitalet (The National Hospital) in Oslo.

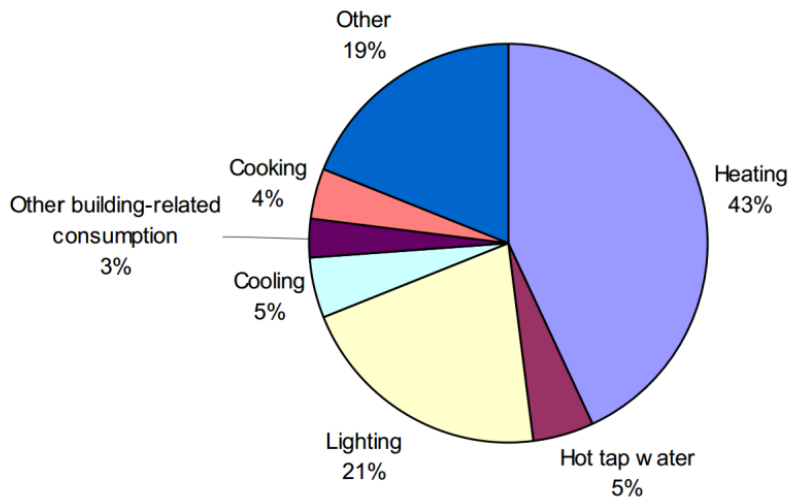

Figure 1. Breakdown of the energy flows in a hospital building [5]

### Form of a hospital building:

The building geometry of hospital has experienced some changes in accordance to flexibility issues and research findings, which shows how daylight is important for recovery of patients.

During the fifties and sixties hospitals were represented by buildings with massive ward blocks [6]. A typical example of that era is a "tower on a base"<sup>6</sup> type of hospital building.

Later in the eighties and nineties, when flexibility became an issue, more neutrally designed buildings appeared [7]. More flexibility and more internally-oriented design with focus on daylight access were programmed in these hospitals. Glazed streets and atriums are distinctive elements in these hospitals. A "glass-covered arcade" type is an example of this type of hospital.

A "Pavilion" type of hospital is suitable, when it comes to fitting the hospital to an urban environment with a lack of available area while keeping daylight access on a quite high level.

### A "tower on a base" type

Figure 2 shows a "tower on a base" hospital. In this type, the lowest 2 (3) floors represent diagnostic and treatment functions as well as public areas such as cafeteria, reception etc. The tower (usually about 10 floors high) represents nursing units. This building is very compact compared to other types of hospital buildings, having smaller surface area exposed to the environment. It is also critical to any rebuilding with a possibility to vertical expansion, which is not always allowed because of regulations and an extra weight on the existing structure. However, adaptation and expansion is also possible on the lowest floors.

<sup>6</sup> Also called "tower on a podium" or "matchbox on a muffin"

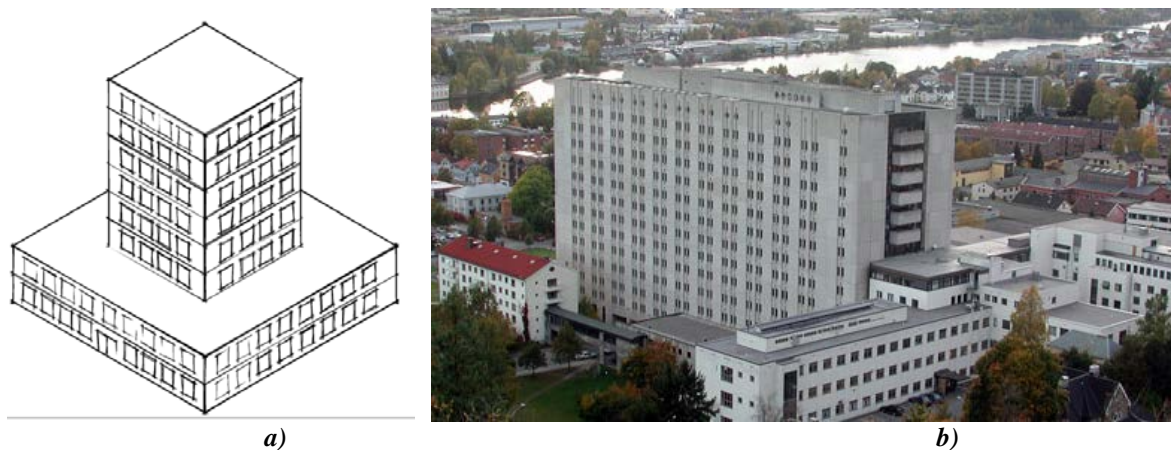

*Figure 2. A tower on a base type. Simplified model (a) and real building (b)  
Glass-covered arcade type*

Figure 3 shows a glass-covered arcade hospital. The glass-covered arcade hospital emerged as a new model in the early eighties and has been employed in several hospital buildings in Norway. Some of the biggest hospitals in Norway namely Rikshospitalet, Østfold hospital (under construction) and AHUS are of this type.

This concept has horizontal building organization as a main feature. Building parts are connected with each other by a glass-covered street. The street combines functions of the main traffic area and also houses some public functions, such as pharmacy, shops, cafeteria and reception. The street provides daylight to the attached areas and also serves as a place which creates social interaction.

### **Pavilion type**

Figure 4 shows a "Pavilion" type of hospital. Several standalone buildings are connected by above- or underground corridors in order to assure proper logistics between the buildings. This type of hospital is quite flexible, when it comes to expansion, if there is enough area available on site. However, it is also possible to build on the top of building elements.

An example of this type of hospital is St. Olav's Hospital in Trondheim, Norway shown in Figure 4 (b).

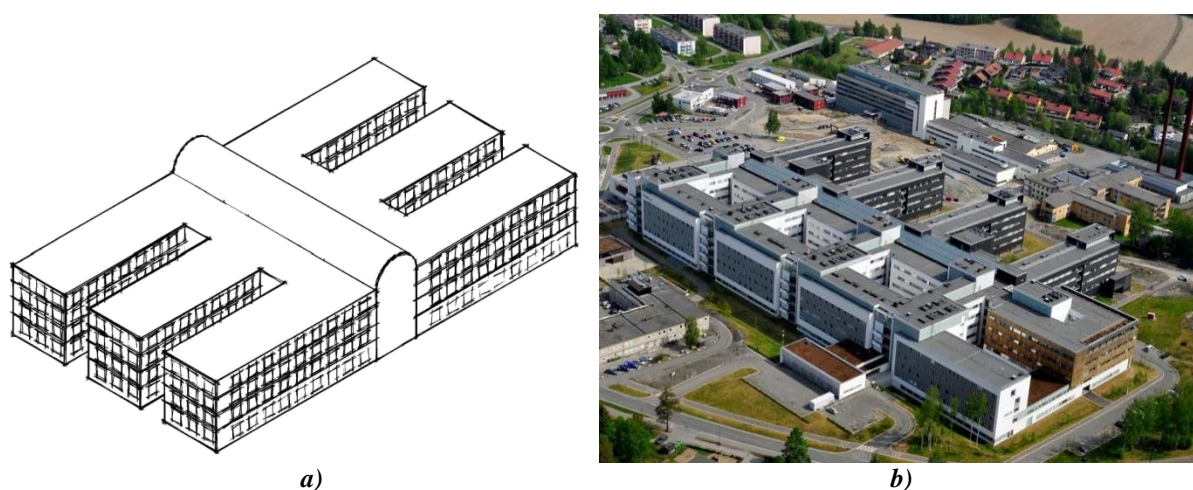

*Figure 3. Glass-covered arcade type. Simplified model (a) and real building (b)*

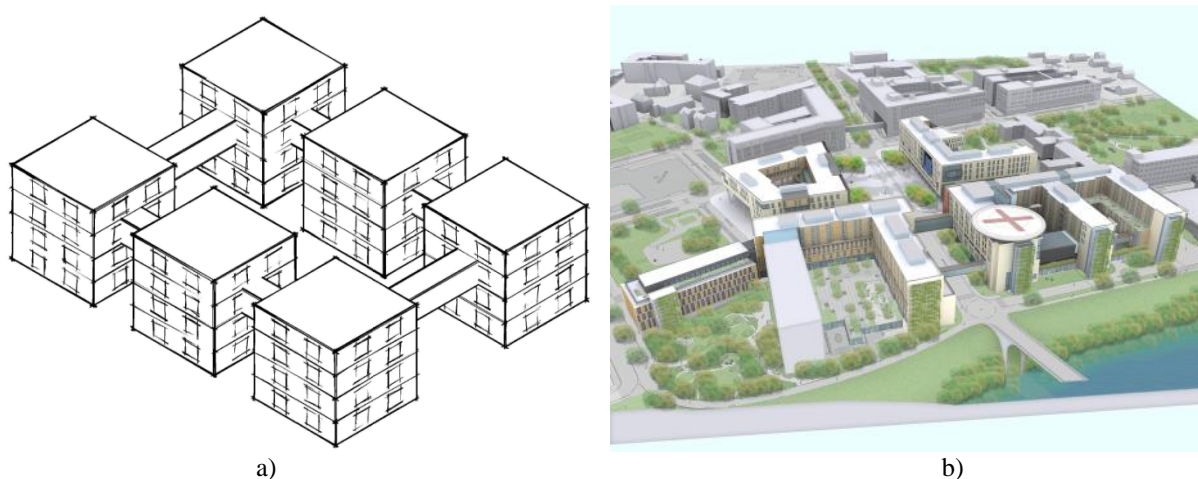

Figure 4. Pavilion type. Simplified model (a) and real building (b)

### Modeling development approach:

In order to investigate the energy performance of the above mentioned hospital building types, three models were created using Simien energy simulation software [1]. All three models were simulated in several stages. In the first stage, characteristics of existing hospital have been applied to see the current situation. In the next simulation rounds energy saving measures have been applied gradually. As shown in Table 1, four simulation rounds were performed for each of the building type.

Table 1 Simulation cases

Case	Case description
a	Existing hospitals, with more than 16/7 <sup>7</sup> operating hours in most of the functional zones
b	energy measures applied to air handling units, in this case reduced SFP <sup>8</sup> factor from 2 to 1.2 kW/(m <sup>3</sup> /s) and better ventilation heat recovery units with 80 % efficiency instead of 70 %
c	energy measures applied to the building body, i.e. better insulated building body (lower heat transfer coefficients, cold bridges and infiltration rate)
D	energy measures which take into account occupants behavior, i.e. lighting and ventilation demand control. It includes automatic on-off light control and dimming, as well as demand control ventilation (when it is rational and dependent on a functional unit).

### Functional zones

The models were divided into a number of zones representing functional units. Each functional unit could be expressed as one or several zones dependent on building geometry. A functional unit can be defined as a group of rooms and related traffic areas interrelated by shared activity or processes. See Table 3 for the full list of the functional units used in the models.

### Base case and low energy hospital

Input data for the building body as well as SFP, infiltration rate and heat recovery efficiency is shown in Table 2.

Input data for internal loads and ventilation rates in the base case hospital are shown in Table 3. Operating schedules for this type of hospital were taken from the Norwegian standard NS 3031 [8], where hospital operates 16/7. However some functional units in Table 3 have other operating hours. For example, acute care and

<sup>7</sup> hours a day / days a week

<sup>8</sup> SFP=Specific Fan Power

nursing units assumed to be in operation 24/7, while administration and research units – just 12 hours a day, which is closer to the real situation.

*Table 2 Input data for the base case and the low energy hospital*

Parameter	Base case hospital	Low energy hospital
Heat recovery efficiency	70 %	80 %
Specific fan power (SFP)	2 kW/(m <sup>3</sup> /s)	1.2 kW/(m <sup>3</sup> /s)
Infiltration rate <sup>9</sup>	1.5 h <sup>-1</sup>	0.6 h <sup>-1</sup>
Cold bridges	0.06 W/m <sup>2</sup> K	0.04 W/m <sup>2</sup> K
U-value external walls	0.21 W/m <sup>2</sup> K	0.13 W/m <sup>2</sup> K
U-value roof	0.2 W/m <sup>2</sup> K	0.11 W/m <sup>2</sup> K
U-value floor	0.11 W/m <sup>2</sup> K	0.1 W/m <sup>2</sup> K
U-value windows	1.17 W/m <sup>2</sup> K	1.0 W/m <sup>2</sup> K

Ventilation, lighting and equipment schedules have the same pattern here. Hot water energy loads for simplicity's sake were assumed to be constant throughout the day.

When it comes to the low energy hospital model, the demand controlled ventilation and lighting were assumed to be used as the major energy saving measures. In order to take into account variable needs in ventilation and lighting, reduction coefficients were used. The coefficients were based on registered activities in two Norwegian hospitals [9] and on a best guess made in cooperation with hospital HVAC consultants. The first two columns in Table 4 show reduction percentage, while the last two show average ventilation rates and lighting loads during the operating hours. Equipment and hot water energy loads are kept the same as in the base case hospital model.

Table 3 The base case air volumes, internal loads and schedules

	Functional unit	Operating schedule, h	Ventilation, m <sup>3</sup> /hm <sup>2</sup>	Lighting, W/m <sup>2</sup>	Equipment, W/m <sup>2</sup>	Hot water, W/m <sup>2</sup>
1	Acute care	24	20(0)	15(0)	20	5.1
2	Out-patient clinic	16	16(5)	15(5)	20(5)	5.1
3	Nursing	24	8(0)	8(0)	12	3.4
4	Surgery	16	50(7)	15(5)	25(0)	5.1
5	Diagnostic imaging	16	16(3)	15(5)	25(5)	3.4
6	Laboratories	16	25(7)	15(5)	20(5)	3.4
7	Pharmacy	16	25(7)	15(5)	20(5)	1.6
8	Sterilization	16	25(7)	8(5)	20(5)	7
9	Medical services	16	16(3)	10(0)	15	5.1
10	Other services <sup>10</sup>	16	16(3)	8(2)	15	5.1
11	Administration	12	16(3)	8(2)	11(2)	1.6
12	Hotel	16	12(3)	8(3)	10(2)	5.1
13	Research/Teaching	12	13(3)	8(2)	11(3)	1.6
14	Personnel service	16	16(3)	8(2)	12	5.1
15	Patient service	16	16(3)	8(2)	15	5.1
16	Technical areas	16	10(3)	8(2)	10	3.4

<sup>9</sup> Shows amount of air changes under 50 Pa pressure difference over the building envelope.

<sup>10</sup> Under "Other services" it is meant reception/admission, kitchen, cleaning, print center, facilities management and other services not directly related to patients treatment.

**Table 4 Reduction of lighting and ventilation loads when demand control systems are installed**

	Functional unit	Ventilation reduction, %	Lighting reduction, %	Ventilation, m <sup>3</sup> /hm <sup>2</sup>	Lighting, W/m <sup>2</sup>
1	Acute care	30	30	14	5.6
2	Out-patient clinic	70	70	4.8(3)	4.5(2)
3	Nursing	65	80	2.8	1.6
4	Surgery	70	70	18(7)	4.5(2)
5	Diagnostic imaging	70	80	4.8(3)	3(2)
6	Laboratories	65	65	7(5)	5.25(2)
7	Pharmacy	65	65	8.75(5)	5.25(2)
8	Sterilization	40	65	12.5(5)	2.8(2)
9	Medical services	65	65	5.6(3)	3.5
10	Other services	50	50	8(3)	5(2)
11	Administration	75	75	4(3)	2(2)
12	Hotel	65	80	4.2(3)	1.6(1)
13	Research/Teaching	75	75	3.2(3)	2(2)
14	Personnel service	85	85	2.4(3)	1.2(1)
15	Patient service	0	20	16(3)	6.4(2)
16	Technical areas	20	20	8(3)	6.4(2)

More details about the models and zones arrangements are shown in Appendices.

### Results:

The results shown in Figure 5 indicate a little impact of the hospital geometry on its energy performance. All the way from the base case to the low energy hospital alternative the difference between the maximum and the minimum values is about 3-4%. Due to the more compact form the "tower on a base" type of hospital shows the lowest energy consumption compared to the other forms in all four cases (a-d). Another thing, which may contribute to a leading position of this type of hospital, is that light intensity was chosen to be constant in each of the simulation rounds for all of the three types. However in the "tower on a base" type it is expected that energy used for lighting is a bit higher compared to the other types due to relatively large area with only artificial lighting (in the core of the building). Drawback of this type of hospital is that healing effects and psychological conditions of patients and their relatives may suffer due to lack of the daylight.

Under extreme polar conditions hospital geometry plays a little more important role than in Oslo climate. However, as shown in Figure 6, the differences between the building geometries are rather small to influence the bigger picture.

The climate place was Kirkenes (69<sup>0</sup> N) - a small town close to the Norwegian-Russian border, with the year average temperature -0.6 °C.

What is remarkable, when comparing Figure 5 and Figure 6, is that the low energy hospital (case d) has almost the same energy consumption in Oslo and Kirkenes climate in spite of the higher year average temperature in Oslo (6.2 °C). At the same time the existing hospital alternative (case a) uses about 20 % more energy in Kirkenes than in Oslo.

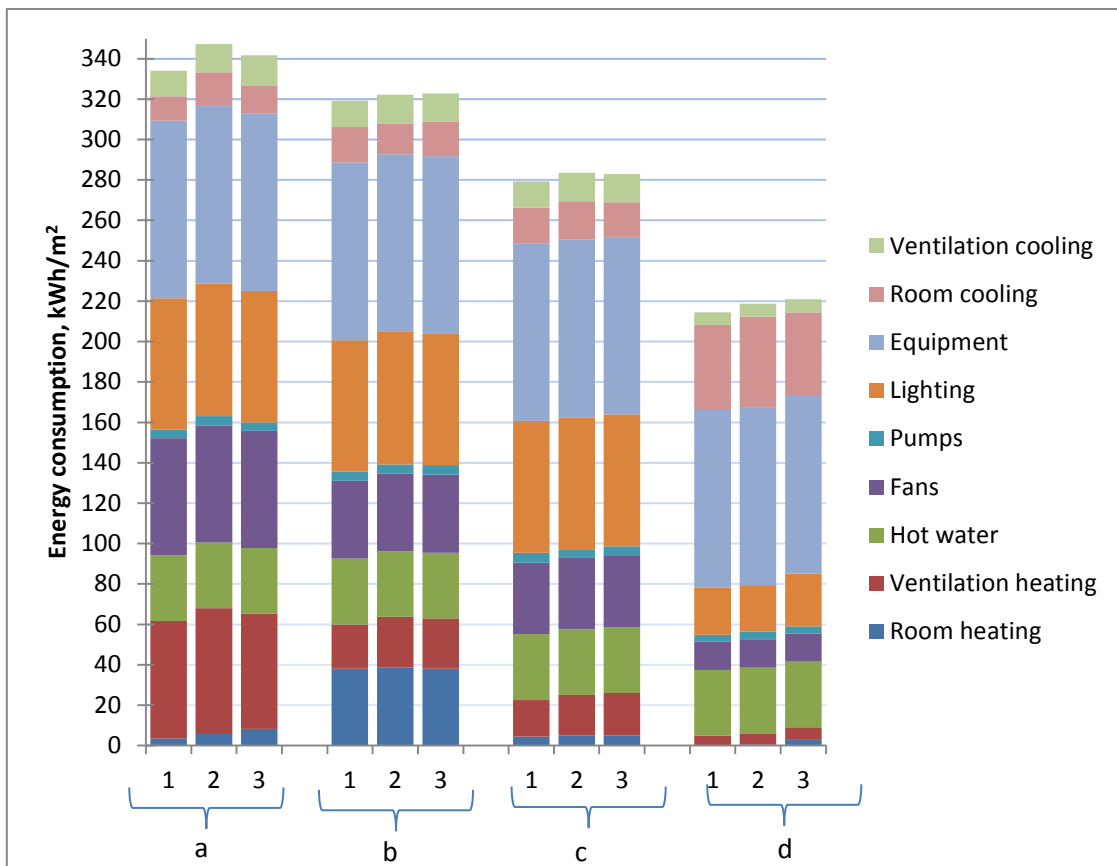

Figure 5 Energy performance of three hospital forms (Oslo climate): 1 - tower on a base, 2 - pavilion, 3 - glass-covered arcade. a-d cases are described in Table 1.

Orientations of the buildings were not taken into consideration. Neither was integration of functional units with simultaneous heating and cooling demand done. An example of a functional unit with almost continuous cooling demand throughout a year could be diagnostic imaging department with heat releasing equipment such as MRT and CT<sup>11</sup>. So it is suggested to investigate this integration in future work.

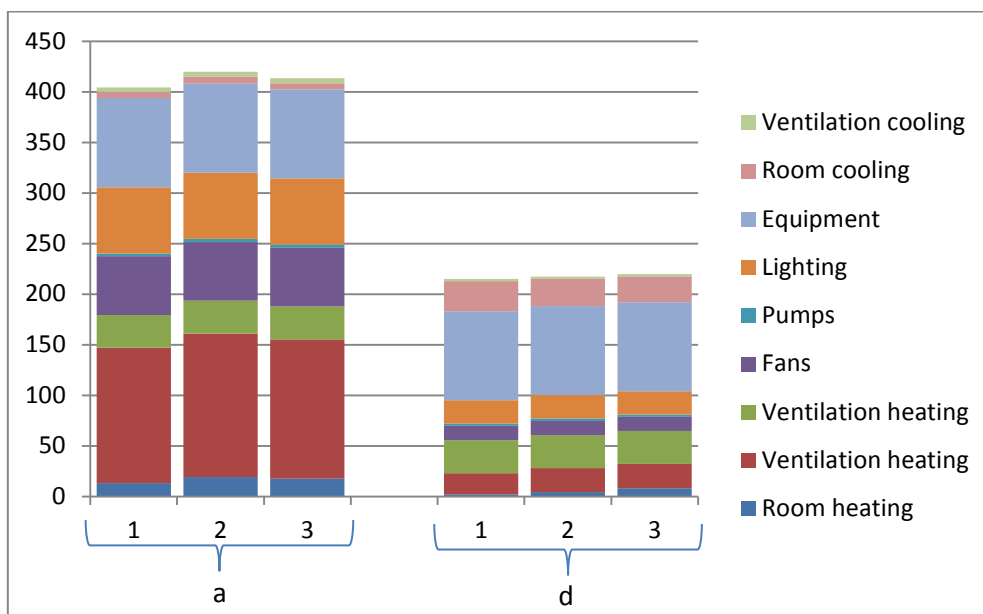

Figure 6 Energy performance of the three hospital buildings in polar climate in Kirkenes (Norway). 1 - tower on a base, 2 - pavilion, 3 - glass-covered arcade

<sup>11</sup> Magnet Resonance and Computer Tomography

**Conclusion:**

As the results show, the difference between different forms of hospital building is marginal. That is why "glass-covered arcade" looks more attractive when access to the daylight is taken into account. Proven daylight's effect on faster recovery of patients [10] and its positive influence on patient's psychological conditions become a critical point in choosing hospital geometry.

Pavilion-type hospital performs the worth which is explained by its larger area exposed to the environment and, hence, higher heat losses.

Hospital model with atrium or glass-covered street has quite high infiltration rate and big air volume needed to be warmed up, but as the results show it does not affect total energy consumption very much.

**Acknowledgements:**

This paper has been written within the ongoing project "Halved energy consumption in future hospitals". The authors gratefully acknowledge the Research Council of Norway.

**References:**

*Simien*. ProgramByggerne.

"Buildings Energy Data Book." [Online]. Available: <http://buildingsdatabook.eren.doe.gov/TableView.aspx?table=1.1.3>. [Accessed: 03-Sep-2013].

S. Erice and Oskia Leyun, "Intelligent Energy Efficiency Control in Hospitals Deliverable 1.1 State of the art document - revised version," CIP-238933, Oct. 2010.

"Department of Energy Announces the Launch of the Hospital Energy Alliance to Increase Energy Efficiency in the Healthcare Sector | Department of Energy." [Online]. Available: <http://energy.gov/articles/department-energy-announces-launch-hospital-energy-alliance-increase-energy-efficiency>. [Accessed: 03-Sep-2013].

Rob van Heur, "Power Quality Utilization Guide," European Copper Institute, Jan. 2008.

J. Hughes, "The 'matchbox on a muffin': the design of hospitals in the early NHS., The 'matchbox on a muffin': the design of hospitals in the early NHS.," *Med. Hist.*, vol. 44, no. 1, pp. 21–56, Jan. 2000.

"THE GENERAL HOSPITAL BUILDING GUIDELINES FOR NEW BUILDINGS," 0.107, Nov. 2002.

"NS 3031:2007+A1:2011 Calculation of energy performance of buildings - Method and data." Standard Norge, 01-Dec-2011.

R. Martinez, T. Rohde, K. Kallmyr, D. Horne, N. Høstvang Melby, J. Vårdal, S. Jerkø, and T. Harsem, "Energy use in hospital. Phase 1," Norconsult, SINTEF, Nov. 2011.

A. Joseph, "The Impact of Light on Outcomes in Healthcare Settings," *Heal. Des.*, no. 2, Aug. 2006.

**Appendices:****Appendix A.** List of the functional units and their areas and shares

	<b>Functional units</b>	<b>Area, m<sup>2</sup></b>	<b>Share of total area, %</b>
1	Acute care	3060	3,2
2	Out-patient clinic	6970	7,2
3	Nursing	17935	18,5
4	Surgery	5270	5,4
5	Diagnostic imaging	3400	3,5
6	Laboratory	7140	7,4
7	Pharmacy	2040	2,1
8	Sterilization	1700	1,8
9	Medical services	3774	3,9
10	Administration	14110	14,6
11	Hotel	2380	2,5
12	Research/Teaching	2380	2,5
13	Personnel services	5984	6,2
14	Patient service	1326	1,4
15	Technical services	14481	15,0
16	Other services	4894	5,1
	<b>Total</b>	<b>96 844</b>	<b>100</b>

**Appendix B.** "Tower on a base" hospital

<b>Floor</b>	<b>Functional units</b>	<b>Area,m<sup>2</sup></b>
ground	Technical areas	14 481
1	Acute care, Pharmacy, Sterilization, Patient service, Out-patient clinic, Research/Teaching	17 476
2	Surgery, Administration	17 476
3	Diagnostic imaging, Medical services	7174
4	Laboratories	7140
5	Personnel services, Administration	7888
6	Nursing	7000
7	Nursing	7000
8	Nursing	6315
9	Other services	4894

**Appendix C.** "Pavilion" hospital

<b>Building Floor</b>	<b>Building 1</b>	<b>Building 2</b>	<b>Building 3</b>	<b>Building 4</b>	<b>Building 5</b>	<b>Building 6</b>
Ground	Technical areas 2413 m <sup>2</sup>	Technical areas 2413 m <sup>2</sup>	Technical areas 2413 m <sup>2</sup>	Technical areas 2413 m <sup>2</sup>	Technical areas 2413 m <sup>2</sup>	Technical areas 2413 m <sup>2</sup>
1	Acute care 3060 m <sup>2</sup>	Sterilization , Pharmacy 3740 m <sup>2</sup>	Medical Services 3774 m <sup>2</sup>	Administration, Research/Teaching 4490 m <sup>2</sup>	Laboratory 3570 m <sup>2</sup>	Administr. 3000 m <sup>2</sup>
2	Surgery 3000 m <sup>2</sup>	Out-patient 3500 m <sup>2</sup>	Nursing 3000 m <sup>2</sup>	Nursing, 3000 m <sup>2</sup>	Laboratory 3570 m <sup>2</sup>	Administr. 3000 m <sup>2</sup>
3	Hotel 2380m <sup>2</sup>	Personnel service 3000 m <sup>2</sup>	Nursing 3000 m <sup>2</sup>	Nursing, 3000 m <sup>2</sup>	Out-patient 3500 m <sup>2</sup>	Administr. 3000 m <sup>2</sup>
4	Surgery 2270 m <sup>2</sup>	Personnel service 3000 m <sup>2</sup>	Nursing 3000 m <sup>2</sup>	Nursing, 3000 m <sup>2</sup>	Diagnostic imaging 3400 m <sup>2</sup>	Administr. 3000 m <sup>2</sup>
5	Patient service 1326 m <sup>2</sup>		Other services 1894 m <sup>2</sup>	Other services 3000 m <sup>2</sup>		



**Appendix D. "Glass-covered arcade" hospital**

<b>Building Floor</b>	<b>Building 1</b>	<b>Building 2</b>	<b>Building 3</b>	<b>Building 4</b>	<b>Building 5</b>	<b>Building 6</b>	<b>Glazed street</b>
Ground	Technical areas 3095 m <sup>2</sup>	Technical areas 3095 m <sup>2</sup>	Technical areas 3095 m <sup>2</sup>	Technical areas 3095 m <sup>2</sup>			Technical areas 2100 m <sup>2</sup>
1	Acute care 3060 m <sup>2</sup>	Sterilization, Pharmacy 3740 m <sup>2</sup>	Medical Service 3774 m <sup>2</sup>	Laboratory 3570 m <sup>2</sup>	Research/ Teaching 2380 m <sup>2</sup>	Administr. 3527 m <sup>2</sup>	Other services (such as reception, cafeteria etc., which are reasonable to place in glazed street) 2100 m <sup>2</sup>
2	Surgery 3000 m <sup>2</sup>	Out-patient care 3500 m <sup>2</sup>	Other services 2794 m <sup>2</sup>	Laboratory 3570 m <sup>2</sup>	Nursing 3000 m <sup>2</sup>	Administr. 3527 m <sup>2</sup>	
3	Hotel 2380 m <sup>2</sup>	Personnel service 3000 m <sup>2</sup>	Nursing 3000 m <sup>2</sup>	Out-patient 3500 m <sup>2</sup>	Nursing 3000 m <sup>2</sup>	Administr. 3527 m <sup>2</sup>	
4	Surgery 2270 m <sup>2</sup>	Personnel service 3000 m <sup>2</sup>	Nursing 3000 m <sup>2</sup>	Diagnostic imaging 3400 m <sup>2</sup>	Nursing 3000 m <sup>2</sup>	Administr. 3527 m <sup>2</sup>	
5		Patient service 1326 m <sup>2</sup>	Nursing 3000 m <sup>2</sup>				

## ANALYSIS OF EFFICIENCY OF TEAM BASED LEARNING (TBL) TECHNOLOGY

*Klara Baidinova, PhD*

*Aigul Zhunusova, PhD*

*Anar Kuanysheva, PhD*

*Saule Maukayeva, PhD*

*Saule Kozhanova, PhD*

*Marat Zhanaspayev, PhD*

*Gulnar Nuralinova, PhD*

*Karlygash Tusupova, PhD*

*Almira Achmetova, PhD*

*Ainash Orazalina, PhD*

Semey State Medical University, Kazakhstan

---

### Abstract

Team based learning is one of the effective technologies used in teaching in preclinical and clinical disciplines in Semey State Medical University. TBL consists of the following stages: individual testing, group testing, clinical case, practical skills, individual testing. During team based learning vertical and horizontal integration is used. Integration is implanted between theoretical disciplines, theoretical and clinical disciplines and between clinical subjects. 100 students and 50 teachers were surveyed about efficiency of TBL. Teachers and students marked that team based learning technology helps to develop competencies, associated with knowledge, practical skills and attitude: Team based learning improves “knowledge and understanding in study area”; “practical skills”, “clinical thinking”; “communication skills”, “skills of scientific research”, “team work skills”. Students put the overage mark of TBL technology – 3,33, teachers – 3,67. Feed back of students and teachers allows to correct content of TBL. Team based learning increases motivation of students, individual and group responsibility, improves communication skills, clinical thinking, reveals leadership. .

---

**Keywords:** Team based learning, clinical and preclinical disciplines, vertical and horizontal integration

### Introduction:

Innovative technologies in medical education increase quality of educational process. In Kazakhstan these technologies are actively implemented. Team based learning is one of the effective technologies used in teaching in preclinical and clinical departments of Semey State Medical University. Generally effective learning includes knowledge, practical skills and attitude. And team based learning promotes many competencies, associated with three domains of learning: communication skills, clinical thinking, leadership, team work skills, responsibility and others. Team based learning in Semey University is implemented in educational process for the 5 years. Learning process in team based learning consists of the following stages: individual testing, group testing, clinical cases, practical skills, individual testing. Students answer on tests individually, then together, in group. The next stage is group’s discussion of clinical cases. Clinical case includes information about patient and

questions. Students should give answers on these questions in group's work. These questions cover all aspects of the studied subject. These aspects depend on the discipline. Preclinical subjects study theoretical questions. In clinical disciplines students study etiology, pathogenesis, diagnosis, differential diagnosis, laboratory diagnosis, treatment, prevention etc. In clinical cases different questions can be used. They deepen and expand the studied topic. After clinical cases students acquire practical skills. Then the teacher delivers material in a form of video, slides, answers to all questions. Finally students answer on individual tests. They may be the same or other and more advanced. Every stage of team based learning is estimated. Percentage of every stage depends on the subject. For example, on theoretical disciplines ascent is made on practical skills, on clinical disciplines a big percentage is clinical case. Last two years teachers of Semey State Medical University actively use vertical and horizontal integration during TBL. Integration of disciplines allows to connect all knowledge, activate previous knowledge and develop metacognition. Integration is conducted between theoretical disciplines, clinical disciplines and theoretical and clinical. For example, horizontal integration is carried out between subjects, which are studied during the academic year (propedeutic of internal disease, pathological anatomy, pathological physiology, pharmacology, visual diagnosis etc.). Vertical integration connects subjects that students studied before and current subjects (pathological anatomy and infectious diseases, epidemiology and infectious diseases, evidence based medicine and internal diseases, anatomy and traumatology). Integration of preclinical disciplines helps students to learn medical sciences completely and deeply, integration of preclinical and clinical subjects introduces the student to the clinical environment, connects theory with clinic. In horizontal integration of clinical subjects students study differential aspects of clinical diagnosis. Team based learning, vertical and horizontal integration are actively implemented during lectures and practical lessons, which are delivered by two and more teachers. Methodical material is made by all teachers. This technology makes real conditions of doctor work. This study is about analysis of efficiency of team based learning technology.

## I.

We analyzed a feedback of students and teachers about team based learning. 100 students and 50 teachers were surveyed. Survey of teachers contained the next questions: 1. What is the stage of innovative technology have you done?; 2. What is the stage of preparation has caused you difficulty and why?; 3. Indicate which competencies of students above technology helps to develop; 4. Do you like the conduct of practical classes on this technique?; 5. If no, what is the reason; 6. Evaluate the effectiveness of new educational technology; 7. Recommendations, comments, suggestions. Survey of students consists of the following questions: 1. What is the innovative technology have used during lesson?; 2. Indicate which your competencies above technology helps to develop; 3. What is the stage of the work has caused difficulties?; 4. Do you like the conduct of practical classes on this technique?; 5. If no, what is the reason; 6. Evaluate the effectiveness of new educational technology; 7. Recommendations, comments, suggestions. Reply of teachers on the first question revealed, that for team based learning they prepared multiple choice questions (MCQ) in 100%, clinical cases in 100%, demonstration of practical skills on video in 26%. On the second question teachers answered, that they had difficulty in preparing of tests (70%), clinical cases (20%), demonstration of practical skills on video (84%). Answers of teacher on third question were following: team based learning improves "knowledge and understanding in study area" in 92%; "practical skills" - 90%; "clinical thinking" - 88%; "communication skills" - 94%; "skills of scientific research" - 60%; "team work skills" - 96%, 6% of respondents answered "nothing competencies", 10% - "difficult to answer". Teachers liked team based technology in 94%. The reasons of dislike of this technology were: "it takes much time for preparing of tests, clinical cases and video", "students may not prepare to lessons".

Teachers put the average mark of TBL technology 3,67 by 4 ball rating score. Recommendation, comments, suggestions of teachers were next: "Students can acquire material, if they are not ready to lesson", "Team based learning is objective assessment of knowledge", "In clinical subjects thematical patient can be absent, in this case TBL (clinical case) helps to make real condition of doctor work", "Team based learning promotes acquirement of practical skills", "During TBL students use their prior knowledge and apply them for current", "Team based learning helps to develop clinical thinking", "Students improve communication skills, team work skills, leadership". Analysis of students answers revealed, that the also mark development of competencies as "knowledge and understanding in study area" in 85%; "practical skills" - 90%; "clinical thinking" - 80%; "communication skills" - 90%; "skills of scientific research" - 40%; "team work skills" - 95%, "nothing competencies" - 5%, "difficult to answer" - 10%. On the question "What stage of team based learning did you like the most?" 16% of students answered that they liked individual testing, 24% of students pleased group testing, 37% of students preferred group discussing of clinical case, 13% of students liked practical skill, 10% - final individual testing. The question "What stage of team based learning was difficult?" revealed next answers. Individual testing was difficult for 19%, group testing - for 13%, group discussion of clinical case - for 30%, practical skills - for 29%, final individual testing - for 9% of students. On question "Did you like practical lesson conducted by team based learning technology" 8% of students had difficulty in answering, 38% of students didn't like, and 54% pleased this practical lesson. The reasons of dislike were the next: "I want only individual grade, don't want to share with other students", "I don't want to answer for students, who didn't prepare lessons".

Recommendations, suggestions, remarks of students were the next: "I wasn't ready to lesson, but after TBL lesson I acquired material", "Perfect students can not defend their opinions", "Perfect students don't mean leaders", "I don't like TBL, because I don't want to be responsible for others", "I like TBL lessons because they are interesting", "The mark in this technology is objective" etc. Students put the average mark of TBL technology - 3,33. Feed back of students and teachers helps to correct and improve content of TBL.

### **Conclusion:**

This study suggests that technology team based learning increases motivation of students, individual and group responsibility, improves communication skills, reveals leadership, makes for acquirement competency. Feed back allows improving of technology.

### **References:**

- Eun-Kyung Chung, Jung-AE Rhee, Young-Hong Baik, Oh-Sun A. The effect of team-based learning in medical ethics education. *Medical Teacher* 2009 31:11, 1013-1017
- Koles PG, Stolfi A, Borges NJ, Nelson S, Parmelee DX. The Impact of Team-Based Learning on Medical Students' Academic Performance. *Acad Med.* 2010 Nov;85(11):1739-45
- Letassy NA, Fugate SE, Medina MS, Stroup JS, Britton ML. Using team-based learning in an endocrine module taught across two campuses. *Am J Pharm Educ.* 2008;72:1-6.
- Michaelsen LK, Sweet M. Fundamental principles and practices of team-based learning. In: Michaelsen LK, Parmelee DX, McMahon KK, Levine RE, eds. *Team-Based Learning for Health Professions Education*. Sterling, Va: Stylus Publishing; 2008.
- Sisk RJ. Team-based learning: systematic research review. *J Nurs Educ.* 2011 Dec;50(12):665-9

# KNOWLEDGE ABOUT HEPATITIS B INFECTION AMONG MEDICAL STUDENTS IN ERBIL CITY, IRAQ

*Samir M Othman, MBChB, MSc, PhD*

*Abubakir M Saleh, MBChB, MSc, PhD*

*Nazar P Shabila, MBChB, MSc, PhD*

College of Medicine, Hawler Medical University, Erbil, Iraq

---

## Abstract

**Background:** Health care personnel especially medical student represent high risk population for hepatitis B virus infection. **Objective:** This study sought to assess the knowledge of medical students regarding hepatitis B infection and its transmission and prevention. **Methods:** A cross-sectional study was conducted on 200 medical students in Erbil, the main city of Iraqi Kurdistan region. A self-administered questionnaire was used for data collection. In addition to basic demographic characteristics, the questionnaire included 18 questions about routes and modes of transmission, sequel and prevention of HBV. The students were also asked about their vaccination status. Statistical package for social sciences was used for data analysis. **Results:** A high proportion of the study participants (41%) had poor knowledge about HBV while 45% had acceptable knowledge and 14% had good knowledge. Good knowledge score was significantly higher among older students and students in clinical year study,  $p < 0.001$ . Only 45% of them were vaccinated against HBV. The vaccination rate was higher among clinical year study students (68%) in comparison to pre-clinical year students (22%),  $p < 0.001$ . The vaccination rate was highest among those who had good knowledge (100%), in comparison to those with acceptable knowledge (53.3%) and poor knowledge (17.1%),  $p < 0.001$ . **Conclusions:** Knowledge about HBV among the medical students in Hawler Medical University is relatively poor, with important gaps which need to be strengthened. A critical level of public awareness and vaccination coverage, particularly among young students, are essential to decrease burden of the disease in Erbil in the future.

---

**Keywords:** HBV, medical students, knowledge, vaccination, transmission

## Introduction

Hepatitis B virus (HBV) is one of the most common viruses in the modern world and ranked by the WHO as one of the top ten killers. The virus is responsible for approximately 1.5 million deaths worldwide each year, two thirds of which are attributable to primary hepatic carcinoma following HBV infection (Martin, 2003; Heymann, 2004). About 360 million people are chronically infected with HBV. These chronically infected persons are at higher risk of death from HBV-related liver cancer or cirrhosis by approximately 25% and over 4 million new acute clinical cases occur (World Health Organization, 2002; Centers for Disease Control and Prevention, 2007). HBV is preventable with a safe and effective vaccine, the first vaccine against cancer due to HBV infection (Centers for Disease Control and Prevention 2003).

HBV is a well-known occupational hazard of health care workers and they are considered to be at substantial risk for acquiring or transmitting the virus because of the occupational contact with blood, blood products and other body fluids (Kohn et al., 2003). The occupational risk for HBV acquisition varies according to the work place in the health care setting and time of exposure to the agent (Ciorlia and Zanetta, 2005).

The practice of modern medicine has widely contributed to increasing the cases and spreading the disease in the society. HBV infection is common due to lapse in the sterilization technique of instruments or due to the improper hospital waste management as 10 to 20% health care waste is regarded hazardous and it may create variety of health risk (Taneja and Biswal, 2006). Among the health care personnel, HBV is transmitted by skin prick with infected, contaminated needles and syringes or through accidental inoculation of minute quantities of blood during surgical and dental procedures. Knowledge regarding HBV and safety precautions is needed to minimize the health care settings acquired infections among health personnel. Health care personnel should have complete knowledge of HBV infections, importance of vaccinations and practice of simple hygienic measures apart from that of specific protective measures. Medical students being part of the health care delivery system are exposed to the same risk as other health care workers when they come in contact with patients and contaminated instruments. They are the first level of contact between patients and medical care. They are expected to undertake activities related to patient care with the beginning of their clinical years. Therefore, this study was conducted to assess the knowledge of medical students regarding hepatitis B infection and its transmission and prevention.

### **Subject and methods**

This cross sectional study was conducted among undergraduate medical students at the College of Medicine of Hawler Medical University from April to May 2012. Hawler Medical University is located in Erbil, the main city of Iraqi Kurdistan region. A total of 200 randomly selected students, from both preclinical (first, second and third year) and clinical (fourth, fifth and sixth year) study years, were invited to participate in the study. A specially designed questionnaire was used for data collection. In addition to basic demographic characteristics, the questionnaire included 18 questions about routes of transmission (7 questions), modes of transmission (6 questions) and sequel and prevention of HBV (5 questions). The students were also asked about their vaccination status. The 18 questions included both correct and wrong statements on general routes and modes of transmission. One of the questions assessed students' knowledge about which virus, HBV or HIV, is more easily spread from person to person. The students were asked to answer each question with 'yes' or 'no'. Each correct answer was given a score of '1' while a wrong answer was given a score of '0'. Students' knowledge was classified to three levels according to the total score obtained; a total score of 0-6 was regarded as poor knowledge, 7-12 as acceptable knowledge and 13 and above as good knowledge.

The questionnaire was reviewed by two other experts from the Department of Community Medicine for validity. It was also pre-tested on ten students from both preclinical and clinical years to assess the reliability. All questions were clearly understood by students. The anonymity of respondents was assured and their verbal consent was obtained. The Research Ethics Committee at Hawler Medical University approved the study.

The statistical package for social sciences version 18 was used for data entry and analysis. Two approaches (descriptive and analytical) were used for data analysis. The first approach was used for determining frequencies, percentages, mean and standard deviation and the second approach used for determination of associations between categorical variables. A p value of  $\leq 0.05$  was regarded as statistically significant.

### **Results**

Of 200 students participated in the study, 55.5% were females and 57% were in age group 20-22 year. Detail of demographic characteristic of participant shown in Table 1.

**Table 1. Demographic characteristics of study sample**

<b>Characteristic</b>	<b>No.</b>	<b>(%)</b>
<b>Sex</b>		
Male	111	55.5
Female	89	44.5
<b>Age (years)</b>		
<20	33	(16.5)
20-22	114	(57.0)
23+	53	(26.5)
<b>Study year</b>		
Preclinical	100	(50.0)
Clinical	100	( 50.0)

A high proportion of the study participants (41%) had poor knowledge about HBV while 45% had acceptable knowledge and 14% had good knowledge. Majority of respondents knew that HBV can be contracted from blood transfusion (80%) and infected needles (71.5%) while (56.5%) said that the disease can be transmitted through sexual contact. The proportions of respondents who had knowledge about household transmission through non-sexual routes like sharing razors, sharing toothbrushes and sharing towels were 47.5%, 60% and 32.5%, respectively. A relatively high proportion of the participants incorrectly identified routes of transmission such as faeco-oral route (38.5%), cough (37%) and holding hands (28%). More than half (51%) of respondents knew that HBV is more easily spread from person to person than HIV, while about 65% of respondents knew that healthy carriers can infect others. Over 45% of participants thought that people with HBV can be infected for life and 64.5% mentioned that HBV can cause liver cancer while 72% considered it a curable disease. In terms of knowledge about preventive measures, 64% of respondents correctly identified vaccination as a way of preventing HBV infection, and only 45% of students were vaccinated against HBV infection. Details of students' knowledge about HBV are shown in Table 2.

**Table 2: Distribution of sample by general knowledge about HBV (n=200)**

<b>Questions</b>	<b>Response</b>			
	<b>Yes</b>		<b>No</b>	
	<b>No.</b>	<b>(%)</b>	<b>No.</b>	<b>(%)</b>
<b>Knowledge about route of transmission</b>				
Sexual contacts	113	(56.5)	87	(43.5)
Infected needles	143	(71.5)	57	(28.5)
Blood transfusion	160	(80.0)	40	(20.0)
Sharing sharps	95	(47.5)	105	(52.5)
Sharing toothbrush	100	(50.0)	100	(50.0)
Sharing towels	65	(32.5)	135	(67.5)
Feco-oral route	77	(38.5)	123	(61.5)
<b>Knowledge about mode of transmission</b>				
HBV is more easily spread from person to person than AIDS	102	(51.0)	98	(49.0)
HBV carriers (although they look healthy) can easily infect others	131	(65.5)	69	(34.5)
HBV can be spread by eating food prepared by an infected person	67	(33.5)	133	(66.5)
HBV can be spread by eating food that has been pre-chewed by an infected person	84	(42.0)	116	(58.0)
HBV can be spread by being coughed on by an infected person	74	(37.0)	126	(63.0)
HBV can be spread by holding hands with an infected person	56	(28.0)	144	(72.0)
<b>Knowledge about sequel and prevention</b>				
People with HBV can be infected for life	91	(45.5)	109	(54.5)
Do you think HBV can cause liver cancer	129	(64.5)	131	(35.5)
HBV disease can cause death	144	(72.0)	156	(28.0)
HBV disease can be cured	130	(65.0)	170	(35.5)
HBV vaccine prevent the infection	128	(64.0)	172	(36.0)

**Received HBV vaccine** **90 (45.0)** **110 (55.0)**

There was no statistically significant association between gender of students and their knowledge scores, while good knowledge score was significantly higher among students aged 23 year and above and students in clinical year study,  $p < 0.001$  (Table 3).

**Table 3: Association between knowledge score and demographic characteristics of study sample (n=200)**

Variable	N	Knowledge				P value		
		Poor (0-6)		Acceptable (7-12)			Good ( $\geq 13$ )	
		No.	(%)	No.	(%)		No.	(%)
<b>Gender</b>								
Female	111	53	(47.7)	45	(40.5)	13	(11.8)	0.094
Male	89	29	(32.6)	45	(50.6)	15	(16.8)	
<b>Age</b>								
<20	33	23	(69.7)	11	(33.3)	0	(0.00)	<0.001
20-22	114	47	(41.2)	58	(50.9)	9	(7.90)	
23+	53	12	(22.6)	21	(39.6)	19	(35.5)	
<b>Study year</b>								
Preclinical	100	47	(47.0)	53	(53.0)	0	(0.00)	<0.001
Clinical	100	25	(25.0)	47	(47.0)	28	(28.0)	

Only 45% students were vaccinated against HBV. The vaccination rate was higher among clinical year study students (68%) in comparison to pre-clinical year students (22%),  $p$  value  $< 0.001$ . The vaccination rate was highest among those who had good knowledge (100%), in comparison to those with acceptable knowledge (53.3%) and poor knowledge (17.1%),  $p < 0.001$  (Table 4).

**Table 4: Association of vaccination status with the study year and knowledge score**

Variable	Vaccination against HBV				P-value
	Yes		No		
	No.	(%)	No.	(%)	
<b>Study year</b>					
Preclinical	22	(22)	78	(78)	<0.001
Clinical	68	(68)	32	(32)	
<b>Knowledge score</b>					
Poor	14	(17.1)	68	(82.9)	<0.001
Acceptable	48	(53.3)	42	(46.7)	
Good	28	(100)	0	(0.00)	

## Discussion

HBV is a major health problem globally casting an enormous burden on health care system and major source of patient's misery (Shepard et al, 2006; Taneja and Biswal, 2006). HBV infection is of intermediate level of endemicity in Middle East and the HBsAg seroprevalence is estimated to be 2.9% in Erbil city (Othman, 2010). Health care related transmissions have long been recognized as a source of HBV infection. Transmission of infection from patients to health care providers was common before widespread HBV vaccination of health care workers (Shepard et al., 2006). Health care workers, especially physicians and medical students are always in direct contact with patients and are vulnerable to the acquisition of these infectious diseases. They are involved in blood transfusion, injections and surgical operations in their practices. They should be aware of the risk involved in the treatment procedures and should take appropriate precautions in dealing with patients (Shepard et al, 2006; Taneja and Biswal, 2006). Assessing people's knowledge is a useful step to assess the extent to which an individual or community is in a position to adopt a disease risk-free behavior for this disease (El-Nasser and El Baset, 2013).

Only a low proportion of study participants (14%) had good knowledge about HBV. In contrary, two other studies from Ahmedabad, India and Erbil, Iraq reported a high



proportion of medical students and health care workers having good knowledge about HBV, 86.7% and 49.3%, respectively (Singh and Jain, 2011; Wadi, 2012). The poor knowledge in this study is alarming and efforts are to be made to explore the reasons behind such poor knowledge and understand whether the actual problem is in the medical curriculum or external factors in the society.

Majority of the medical students in this study identified blood transfusion and contaminated needles as the most important route of HBV transmission. However, a relatively low proportion of them identified sexual contact and sharing of household tools as important routes of transmission. In two other studies from Pakistan and India, an even higher proportion of medical students identified the most common modes of transmission of HBV correctly (Raza et al., 2008; Singh and Jain, 2011). Research from different settings has shown that blood and its products followed by infected needles are usually mentioned by most study participants as the most important route of transmission of HBV particularly by health care workers and medical students (Raza et al., 2008; Samuel et al., 2009). However, sexual contact is usually less commonly mentioned as a route of transmission (Samuel et al., 2009). Interestingly, many study participants wrongly identified feco-oral route and its attributes like eating food prepared by an infected person and cough as modes of transmission. Such wrong perception might be related to their confusion between HBV and Hepatitis A virus infection which is common among people.

In this study, around half of students recognized that HBV is more easily transmitted than HIV. The wrong understanding of HIV being easier transmissible than HBV is common in many societies where HIV is a source of panic and stigma. For example a study from Puerto Rico showed that less than one-third of adults agreed that HBV is more easily spread than HIV (Soto-Salgado et al., 2011). However, it is striking to have such wrong understanding among medical students too.

There was no statistically significant association between gender of students and their knowledge scores, while good knowledge score was significantly higher among older students and clinical year study students. A similar study from Egypt showed no statistically significant association between knowledge and age and gender of the students (El-Nasser and El Baset, 2013). The level of knowledge regarding HBV was fairly good among clinical year students as compared to pre-clinical students. There is no formal school based health education regarding communicable diseases for pre-clinical students in the curriculum of medical college which may be the important reason of lower knowledge about HBV among them. Higher level of knowledge about HBV among clinical students compared to preclinical students has been also reported from other settings (Singh and Jain 2011). The higher knowledge among students aged 23 year and above compared to younger students in this study could simply be due to having these students at clinical study years.

Students' knowledge about HBV vaccine was not satisfactory, in which 64% of students had knowledge about vaccination against HBV infection as one way of prevention of the disease. A low proportion of the students (45%) had received HBV vaccination. The reason for such low vaccination rate could be attributed to two main factors. Firstly, vaccination against HBV was not introduced to the expanded program of immunization program in Iraq until 2003. Secondly, HBV vaccination is also not routinely provided to medical students in Iraq.

HBV vaccination rate was significantly higher among clinical year students (68%) than pre-clinical students (22%). This finding was in disagreement with another study from India where 84 % of the medical students in the second year were completely vaccinated for HBV as compared to 50-60% of the third year students (Singh and Jain, 2011). The lower vaccination rate among pre-clinical year students might be attributed to fact that clinical year students have more knowledge about the disease and the fact that lack of awareness is the commonest reason for not having vaccination against HBV (Younis et al., 2001). Therefore,

the vaccination rate was significantly higher among those who had good knowledge (100%), in comparison to those with acceptable knowledge (53.3%) and poor knowledge (17.1%).

People particularly health care workers who lack adequate knowledge about HBV might ignore the importance of vaccination. Another study from Erbil, Iraq also showed a high vaccination rate (64.6%) among the health workers who scored significantly higher on HBV knowledge-based questions; while only small percent (28.8%) of those with poor knowledge score were vaccinated against HBV (Wadi, 2012).

This study has a number of limitations. It covered a relatively small sample of medical students from one city of Iraqi Kurdistan region. It does not cover nursing and dentistry students that are also frequently exposed to the risk of HBV infection. The findings are limited to the medical students in Erbil city only while there are medical schools in the other two cities of Iraqi Kurdistan region. The relatively small sample makes it difficult to detect factors that have statistically significant association with students' knowledge and vaccination status. The findings particularly in terms of vaccination status are liable to information bias as it merely based on students' report without cross-checking with their vaccination records.

### **Conclusion**

Medical students' knowledge about HBV in Hawler Medical University is relatively poor, with important gaps which need to be filled. A critical level of public awareness and vaccination coverage, particularly among young students, are essential to decrease burden of the disease in Erbil in the future. Further research needs to explore the reasons behind such poor knowledge in a more in-depth manner.

### **References:**

- Centers for Disease Control and Prevention. Childhood and adult immunization schedules: National immunization program. 2003. Available from: <http://www.cdc.gov/nip/recs/child-schedule> [accessed 4 June, 2007].
- Centers for Disease Control and Prevention. Guidelines for prevention of transmission of human immunodeficiency virus and hepatitis B virus to health-care and public-safety workers. *Morb Mortal Wkly Rep* 38 (suppl 6): 1–37. 1989.
- Centers for Disease Control and Prevention. HBV a silent killer. 2007. Available from: [http://www.cdc.gov/ncidod/disease/hepatitis/b/hbv\\_silent\\_killer](http://www.cdc.gov/ncidod/disease/hepatitis/b/hbv_silent_killer) [Accessed 19 February, 2007].
- Ciorlia LA, Zanetta DM. Hepatitis B in healthcare workers: prevalence vaccination and relation to occupational factors. *Braz J Infect Dis* 9(5): 384-389. 2005.
- El-Nasser GA, El Baset EA. Assessment of students knowledge and attitude toward hepatitis B and C in Sohag University/Egypt. *Kufa Journal for Nursing Sciences* 3(1): 1-14. 2013.
- Heymann DL. *Control of communicable diseases manual*. 17th ed. Washigton: American Public Health Association. 2004.
- Kohn WG, Collins AS, Cleveland JL, Harte JA, Eklund KJ, Malvitz DM 2003. Guidelines for infection control in dental health-care settings. *Morb Mortal Wkly Rep; RR-52 (RR-17)*: 1-61. 2003.
- Martin NA. The discovery of viral hepatitis: A military perspective. *J R Army Med Corps* 149: 121-124. 2003.
- Othman SM. *Epidemiology and risk factors of hepatitis B infection in Kurdistan region*. Unpublished PhD thesis. College of Medicine, Hawler Medical University, Erbil, Iraq. 2010.
- Raza W, Tariq W, Zafar Z, Ali I. Khar MU, Khurram M. Knowledge, attitude and practices (KAP) of medical students towards Hepatitis B and C. *Ann Pak Inst Med Sci* 4(2):116-120. 2008.

- Samuel SO, Aderibigbe SA, Salami TAT, Babatunde OA. Health workers' knowledge, attitude and behavior towards hepatitis B infection in Southern Nigeria. *International Journal of Medicine and Medical Sciences* 1(10): 418-424. 2009.
- Shepard CW, Simard EP, Finelli L, Fiore AE, Bell BP. Hepatitis B virus infection: epidemiology and vaccination. *Epidemiol Rev* 28: 112-25. 2006.
- Singh A, Jain S. Prevention of hepatitis B - Knowledge and practices among medical students. *Healthline* 2(2): 8-11. 2011.
- Soto-Salgado M, Suárez E, Ortiz AP, Adrovet S, Marrero E, Meléndez M, et al. Knowledge of viral hepatitis among Puerto Rican adults: implications for prevention. *J Community Health* 36(4): 565-573. 2011.
- Taneja N, Biswal M. Safe disposal of infectious waste - Indian perspective. *J Hosp Infect* 62(4): 525-526. 2006.
- Wadi FH. Knowledge and practices of health care workers about Hepatitis B in Erbil city. Unpublished Thesis. Baghdad; Iraqi Board for Medical Specializations. 2012.
- World Health Organization. Hepatitis B. 2002. Available from: <http://www.who.int/csr/disease/hepatitis/whocdscsrlyo2002/en> [accessed 11 October, 2008].
- Younis BB, Khan GM, Akhtar P, Chaudhary MA. Vaccination against hepatitis B among doctor at a teaching hospital at Lahore. *Pak J Med Sci* 17: 229-232. 2001.

# ADJUVANT CHEMOTHERAPY EFFECTIVENESS FOR I–II STAGE NON-SMALL CELL LUNG CANCER (NSCLC) PATIENTS DEPENDING ON THE TUMOR MOLECULAR PROPERTIES

*O. P. Kolesnik*

Zaporizhzhya State Medical University, Department of oncology

---

## Abstract

Adjuvant chemotherapy use on early stages non-small cell lung cancer patients remains the debatable issue. For individualization purpose of adjuvant chemotherapy administration it is possible to use molecular prognostic/predictive markers. The goal of our study was to investigate the adjuvant chemotherapy effectiveness on early stage NSCLC patients depending on the various molecular markers expression in primary tumor. Included in research are 254 patients with I–II stage non-small cell lung cancer (NSCLC) that received institutional treatment in the department of thoracic surgery of Zaporizhzhya Regional Clinical Oncologic Dispensary starting from June of 2008 up to December of 2012. For adjuvant chemotherapy administration individualization purpose the following molecular markers were used: Ki-67, CD31/CD34, Pan-Cytokeratin, Her-2/neu, p53, E-cadherin, EGFR. Low Ki-67, CD31/CD34, p53 expression level is a marker of adjuvant chemotherapy negative influence on early stage NSCLC patients survival rate. Alternatively, at high expression level of the said markers the adjuvant chemotherapy administration significantly improves examined patients survival rate. Pan-Cytokeratin indicates the presence of micrometastases in the lung root lymph nodes, and those are such patients, whose survival rate is improved by adjuvant chemotherapy conduction. Her-2/neu is the marker of tumor chemoresistance, more specifically, for patients with high expression level of such marker conducting of adjuvant chemotherapy is not appropriate, because this type of treatment does not improve survival at indicated marker characteristics. At the same time, low level of Her-2/neu expression is a marker of chemosensitivity and adjuvant chemotherapy conduction on such patients improves their survival rate. Significant predictive connection of E-cadherin EGFR expression level, high Her-2/neu expression and the absence of micrometastases is not established.

---

**Keywords:** Adjuvant chemotherapy, non-small cell lung cancer, Ki-67, survival rate

## Introduction:

Surgery remains the basic method of treatment for patients with early (I-II) stages of non-small cell lung cancer (NSCLC). However, for 50-60% of patients the disease progression occurs after surgical interference. In order to improve outcomes of patients with early stages of NSCLC the use of adjuvant chemotherapy on the basis of platinum-based drugs is possible. Adjuvant chemotherapy effectiveness for this category of patients is still debated. A number of studies found no improvement in survival rate in patients after conducting of adjuvant chemotherapy [5,6,8]. According to other authors' data adjuvant chemotherapy is effective for patients with II and IIIA stages of NSCLC [1,2,7,9].

Perhaps, the difference of the received data is due to the heterogeneity of patients involved in the research. Today it is known that NSCLC patients form the heterogeneous

group, even within the same stage, which is associated with tumor molecular characteristics [3,4]. Molecular markers may be used in order to separate subgroups.

**Materials and Methods:** 254 patients with I–II stage non-small cell lung cancer (NSCLC) that received institutional treatment in the department of thoracic surgery of Zaporizhzhya Regional Clinical Oncologic Dispensary are included in research. Patients' average age amounts to 60,7 years (95% CI 59,7-61,7). All patients underwent surgical treatment in the amount of lobectomy or pneumonectomy. Adjuvant chemotherapy was conducted for 52 patients with I stage of NSCLC and 49 patients with II stage of the disease. Adjuvant chemotherapy conduction for patients with I stage of NSCLC is not the care standard, in connection with which after explaining of all the possible positive and negative adjuvant chemotherapy effects, 119 patients refused additional therapy offer. Part of the patients with stage II (n=34) did not receive adjuvant chemotherapy due to comorbidity, or rejection of this type of treatment. Adjuvant chemotherapy involved 2-3 courses of platinum-based chemotherapy (80mg/m<sup>2</sup> of cisplatin for 1 day, 120 mg/m<sup>2</sup> of etoposide from the 1st to the 3rd day, with 21-day interval between the courses). Chemotherapy treatment was initiated within 21 days after surgery.

For adjuvant chemotherapy administration individualization purpose the following molecular markers were used: Ki-67, CD31/CD34, Pan-Cytokeratin, Her-2/neu, p53, E-cadherin, EGFR.

X<sup>2</sup> criterion and Pearson's chi-squared test were used for patients with adjuvant chemotherapy and without additional treatment in order to evaluate the connection between various clinical and morphological features. The survival rate was estimated using the Kaplan-Mayer function. Survival rate difference of individual groups was examined using log-rank criterion. The significance level was defined as p<0.05. Statistica 6.0. Software package was used for material statistical processing.

**Results of research:** One of the most important tumor properties is its proliferative activity. The adjuvant chemotherapy effectiveness was analyzed for patients with low and high proliferative activity. For patients with low proliferative activity median survival after conducting of adjuvant chemotherapy amounted to 25 ± 3,7 months, while for patients for whom the additional treatment was not conducted the survival rate was significantly higher (p<0,001) - median survival was not reached (Fig. 1.). In other words for patients with low proliferation level the conducting of adjuvant chemotherapy significantly worsens their survival rate.

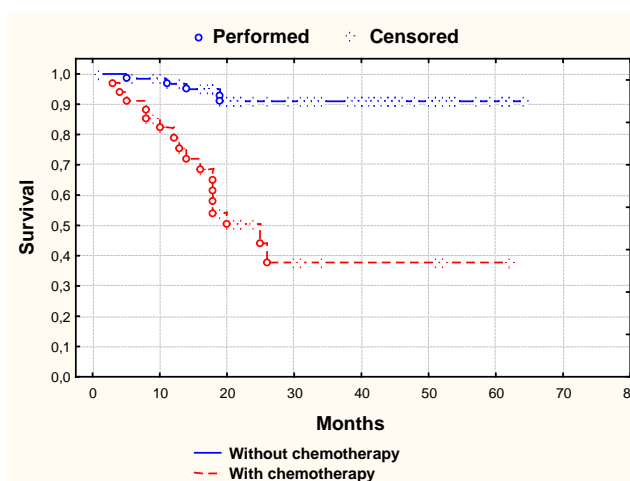

Fig. 1. Patients' survival rate at early NSCLC stage with low proliferative activity level depending on adjuvant chemotherapy administration

However, for patients with high proliferation in primary tumor, who had received adjuvant chemotherapy, survival rate considerably increased (p<0,001, Fig. 2.).

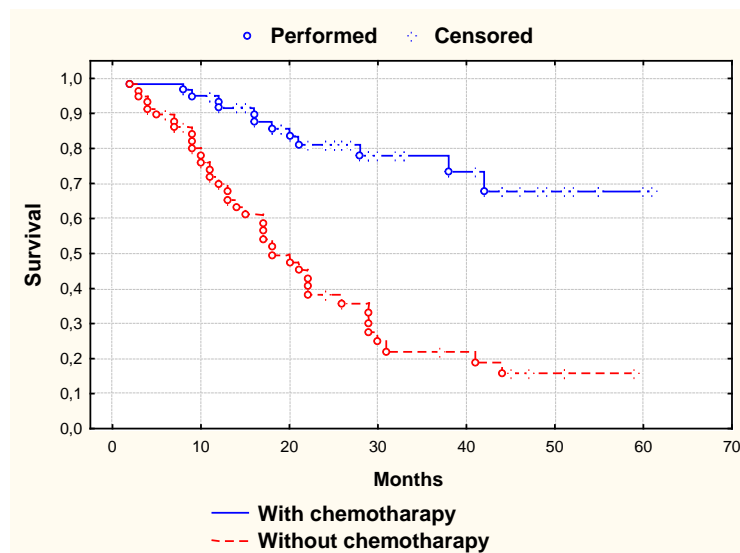

Fig. 2. Patients' survival rate at early NSCLC stage with high proliferative activity level depending on adjuvant chemotherapy administration (institution)

Thus, for patients with high proliferation index, which had received adjuvant chemotherapy, the median survival was not achieved. The 75th percentile of survival equals to  $38 \pm 11,4$  months. The survival rate of patients that had not received additional chemotherapy treatment was almost two times less. In this case 75th percentile of survival rate amounted to  $11,0 \pm 1,8$  months. Therefore, conducting of adjuvant chemotherapy is only necessary for patients with high malignant neoplasms proliferative activity.

Another molecular factor that was analyzed was the tumor microvessels density (MD), which was analyzed with the help of CD31/CD34 expression. For patients with low tumor MD that had received adjuvant chemotherapy in the postoperative period, median survival amounted to 42.0 months, whereas for patients with a similar molecular characteristics of the tumor that had not received adjuvant chemotherapy this indicator was not achieved. Survival rate in two groups was different ( $p=0,005$ , Fig. 3).

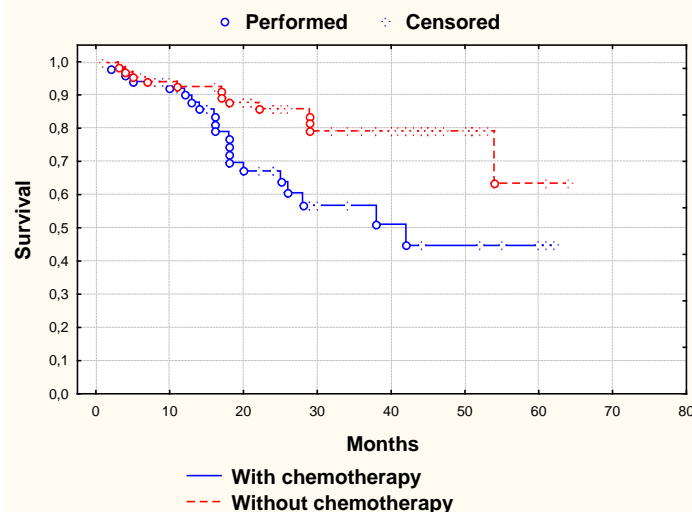

Fig. 3. Patients' survival rate at early NSCLC stage with low microvessels density level depending on adjuvant chemotherapy administration

For patients with high tumor microvessels density level the conducting of adjuvant chemotherapy conversely improved distant survival rate ( $p=0,003$ , Fig. 4.). Thus, the median survival of patients with high primary tumor MD after further postoperative chemotherapy was not achieved, while the median survival of patients without adjuvant chemotherapy was 30.0 months.

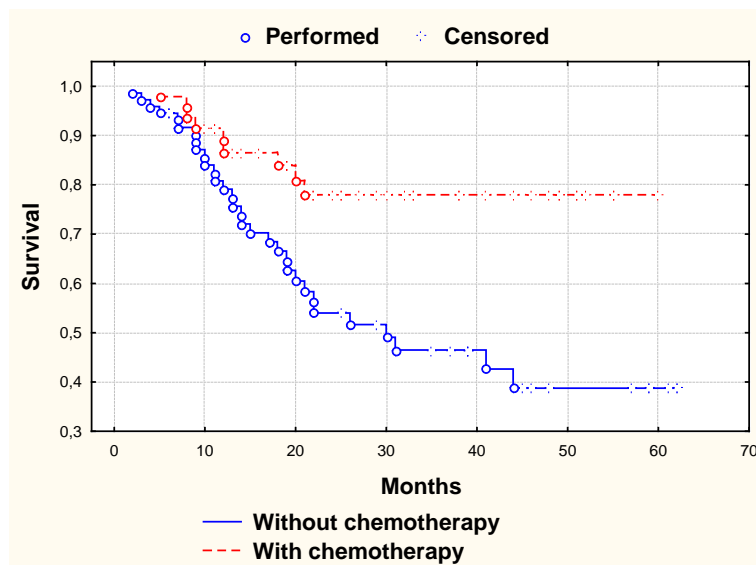

Fig. 4. Patients' survival rate at early NSCLC stage with high microvessels density level depending on adjuvant chemotherapy administration.

Thus, there is a need of adjuvant chemotherapy conducting only in cases with high primary tumor MD and it is of no use when MD is low.

Another factor except for the proliferative activity and tumor MD that was analyzed is the existence of micrometastases in the lung root lymph nodes, which was assessed with the help of Pan-Cytokeratin expression. In the absence of micrometastases the survival rate of patients did not change after adjuvant chemotherapy appointment ( $p=0,884$ ). Thus, the median survival was not achieved within the group of patients without micrometastases and without adjuvant chemotherapy conducting and for patients without micrometastases with conducting of adjuvant chemotherapy. This indicates adjuvant chemotherapy efficacy lack for patients without micrometastases. Additional chemotherapy effectiveness assessment for patients with micrometastases on the contrary showed a significant difference in survival rate of patients with and without adjuvant chemotherapy conducting ( $p=0,005$ , Fig. 5). Thus, the median survival rate of patients with micrometastases in the lung root lymph nodes after conducting of adjuvant chemotherapy was not achieved, while the median survival of patients without additional treatment was  $13,0 \pm 6,3$  months.

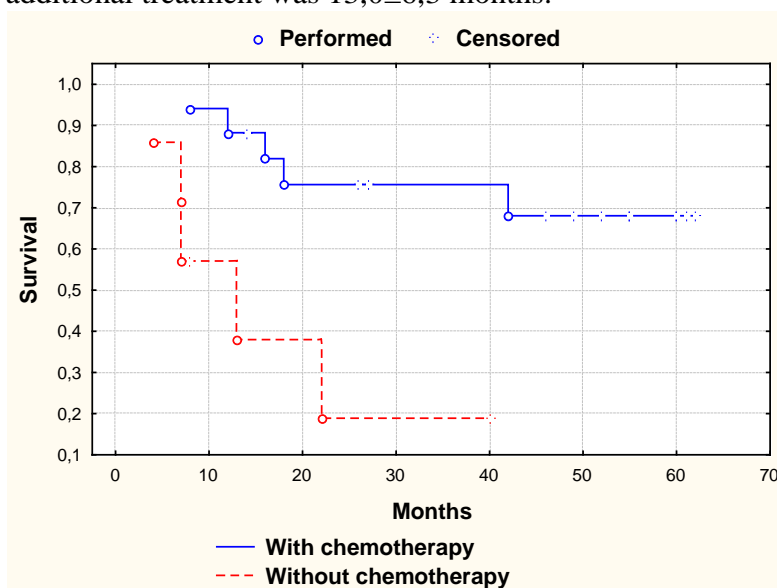

Fig. 5. Patients' survival rate at early NSCLC stage with micrometastases in the lymph nodes of root of the lung depending on adjuvant chemotherapy administration.

In recent years, increasing attention was paid to the status of the epidermal growth factor receptor in primary lung tumors. In our research, we have examined the EGFR and Her-2/neu expression, and also analyzed the adjuvant chemotherapy effectiveness depending on indicated markers expression level.

Patients with low EGFR expression level: median survival is not achieved by patients without further treatment in the postoperative period and as well as by patients with conducting of adjuvant chemotherapy. The difference in the survival of two groups was not statistically significant ( $p=0,877$ ). Similar results were obtained for patients with high EGFR expression level. The median survival rate of patients with adjuvant chemotherapy amounted to 25.0 months, and patients without adjuvant chemotherapy - 30.0 months. There is no difference in survival rate ( $p=0,560$ ). Therefore, the expression of EGFR is not a predictive factor for adjuvant chemotherapy efficiency for patients with early-stage NSCLC.

The studied patients in terms of Her-2/neu predictive role, were also divided into groups of patients with low and high levels of marker expression. 75th percentile survival rate was not achieved for patients with low Her-2/neu expression after conducting of additional treatment. At the same time, patients with low expression and no adjuvant chemotherapy had a significantly lower survival rate - 75th percentile survival amounted to 41 months ( $p = 0.019$ , Fig. 6).

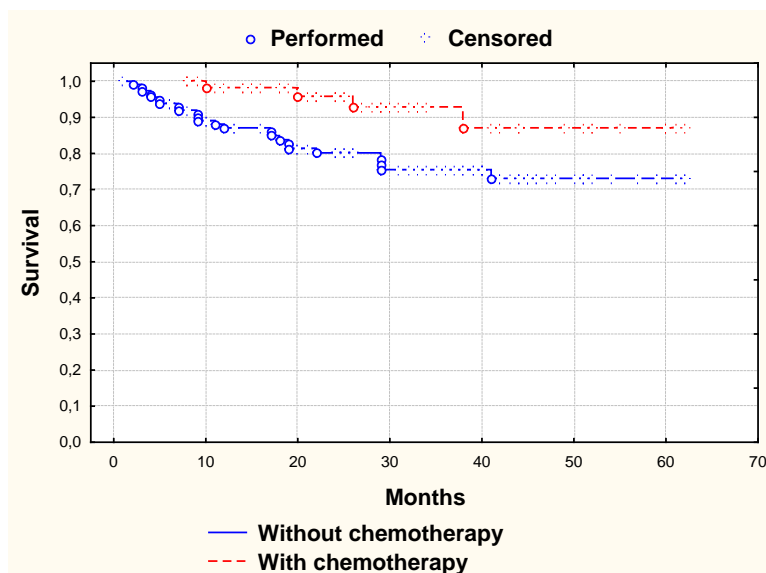

Fig. 6. Patients' survival rate at early NSCLC stage with low Her-2/neu expression level depending on adjuvant chemotherapy administration

For patients with high Her-2/neu expression level adjuvant chemotherapy conduction impact was not observed ( $p=0,880$ ). The median survival of patients with adjuvant chemotherapy amounted to 18.0 months, and in the absence of additional postoperative chemotherapy - 21.0 months.

Thus, high level of Her-2/neu indicates tumor chemoresistance.

The following researched the molecular marker is p53 apoptosis marker. Apoptosis is one of tissue important properties, including the tumor tissue. In order to conduct the research of adjuvant chemotherapy predictive value, all patients included in the research were divided into groups of patients with high and low levels of p53 expression, and then the survival rate was determined in each group, depending on adjuvant chemotherapy conducting.

As shown in Figure 7 significant difference in the survival rate of patients with low p53 expression was marked, moreover, patients who had received chemotherapy had significantly worse survival rate (median survival - 26.0 months) compared to the patients who had not received adjuvant chemotherapy - median survival was not achieved. The difference in survival is statistically significant ( $p=0,008$ ).



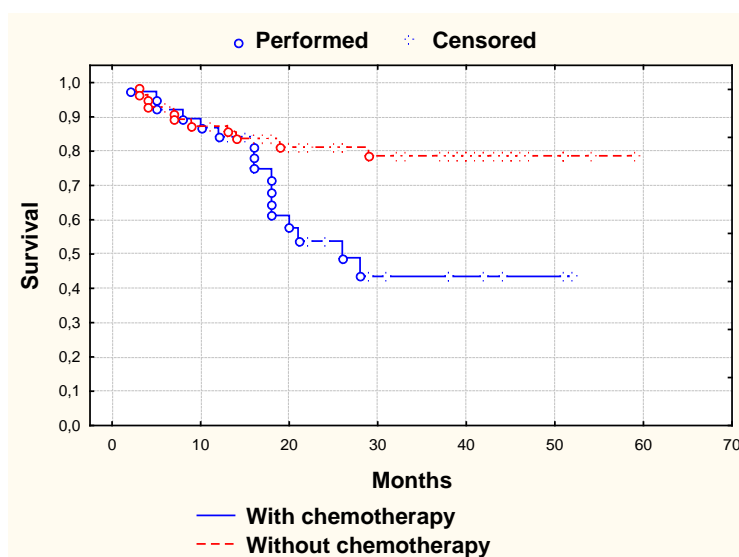

Fig. 6. Patients' survival rate at early NSCLC stage with low p53 expression level depending on adjuvant chemotherapy administration

In the presence of early-stage NSCLC patients high p53 expression we have also detected a significant difference in survival rate for patients who had received adjuvant chemotherapy and patients that had not received additional treatment ( $p = 0.002$ ). In Fig. 8. it is shown that the median survival of patients with high p53 expression and conducted adjuvant chemotherapy was not achieved. For patients with p53 overexpression and without additional treatment the median survival amounted to  $31,0 \pm 7,9$  months.

Thus, adjuvant chemotherapy conducting for patients with p53 overexpression has a significant positive effect on survival of patients with stage I-II NSCLC. As opposed to this the conducting of additional postoperative chemotherapy for patients with low expression significantly worsened their survival rate.

Last molecular marker that has been analyzed is E-cadherin - cell adhesion marker. For patients with low E-cadherin expression level and that had not received adjuvant chemotherapy the median survival was not achieved. While after the conducting of adjuvant chemotherapy it equaled 20.0 months, this difference is not statistically significant ( $p = 0.101$ ). At the same time, survival rate of patients with high E-cadherin expression level was also not improved by adjuvant chemotherapy ( $p = 0.452$ ). Median survival was not achieved by both: patients after conducting of adjuvant chemotherapy and patients that had not received additional postoperative treatment.

Therefore, out of all analyzed markers the following ones are predicatively significant: Ki-67, CD31/CD34, Her-2/neu, p53, Pan-Cytokeratin.

Ki-67, CD31/CD34, p53 low expression levels are adjuvant chemotherapy negative impact marker on patients with early-stage NSCLC survival rate. On the contrary, at these markers high expression levels the adjuvant chemotherapy appointment significantly improves the studied patients' survival rate. Pan-Cytokeratin indicates the micrometastases presence the lymph nodes of root of the lung and for these types of patients the conducting of adjuvant chemotherapy improves the survival rate. Her-2/neu is a marker of tumor chemoresistance, and for patients with high expression level of this marker, in particular, the conducting of adjuvant chemotherapy is not reasonable, since this type of treatment does not improve survival rate under the specified marker characteristic. At the same time, low Her-2/neu expression level is a marker of chemo sensitivity and the conducting of adjuvant chemotherapy for such patients improves their survival rate.

Patients' median survival analysis with different molecular markers expression and conducting or absence of adjuvant chemotherapy was carried out in order to confirm the obtained data (Table 1).

*Table 1* I-II stage NSCLC patients survival rate depending on the molecular markers expression level and prescribed treatment

Marker	Patients number	Median survival	p
Pan-Cytokeratin IHC (immune histochemical study) (-)			
Observations	104	NA*	0,884
Adjuvant chemotherapy	52	NA *	
Pan-Cytokeratin IHC (+)			
Observations	7	13,0±6,3	0,005
Adjuvant chemotherapy	17	NA *	
E-cadherin IHC (-)			
Observations	33	NA *	0,101
Adjuvant chemotherapy	29	20,0±4,0	
E-cadherin IHC (+)			
Observations	74	NA *	0,452
Adjuvant chemotherapy	33	NA *	
EGFR IHC (-)			
Observations	60	NA *	0,877
Adjuvant chemotherapy	42	NA *	
EGFR IHC (+)			
Observations	66	30,0±10,7	0,560
Adjuvant chemotherapy	31	25,0±6,3	
CD31/CD34 IHC (-)			
Observations	70	NA **	0,005
Adjuvant chemotherapy	51	42,0±11,5	
CD31/CD34 IHC (+)			
Observations	73	30,0±8,9	0,003
Adjuvant chemotherapy	47	NA *	
p53 IHC (-)			
Observations	56	NA *	0,008
Adjuvant chemotherapy	38	26,0±5,3	
p53 IHC (+)			
Observations	84	31,0±7,9	0,002
Adjuvant chemotherapy	42	NA *	
Her-2-neu IHC (-)			
Observations	115	NA *	0,019
Adjuvant chemotherapy	58	NA *	
Her-2-neu IHC (+)			
Observations	30	21,0±2,5	0,88
Adjuvant chemotherapy	40	18,0±1,8	
Ki-67 IHC (-)			
Observations	63	NA *	p<0,001
Adjuvant chemotherapy	34	25,0±3,7	
Ki-67 IHC (+)			
Observations	58	18,0±2,3	p<0,001
Adjuvant chemotherapy	61	NA	

\* Note: NA - not achieved

As is evident from table data, the significant predictive connection of E-cadherin, EGFR expression level, high Her-2/neu expression and micrometastases absence was not detected. Further data meets the abovementioned and once again confirms the results.

### Conclusion

1. Of all analyzed markers the following are predicatively important: Ki-67, CD31/CD34, Her-2/neu, p53 and Pan-Cytokeratin.
2. Ki-67, CD31/CD34, p53 low expression level is adjuvant chemotherapy negative impact marker for early stage NSCLC patients survival rate and vice versa at these markers

high expression levels the adjuvant chemotherapy appointment significantly improves survival rates.

3. Pan-Cytokeratin expression presence indicates micrometastases in lymph nodes of root of the lung, and for these patients the adjuvant chemotherapy appointment improves survival rates.

4. Her-2/neu is a marker of tumor chemoresistance. Thus, for patients with high expression level of this marker, in particular, the conducting of adjuvant chemotherapy is not reasonable, since it does not improve survival rate. At the same time, the low Her-2/neu expression is a marker of chemo sensitivity and the appointment of adjuvant chemotherapy improves such atients' survival rate significantly.

#### **References:**

Arriagada R, Bergman B, Dunant A, Le Chevalier T, Pignon JP, et al. Cisplatin-based adjuvant chemotherapy in patients with completely resected non-small-cell lung cancer // *N Engl J Med.* – 2004. – Vol. 350. – P. 351–60.

Douillard J.Y., Rosell R., Delena M., et al. ANITA: Phase III adjuvant vinorelbine (N) and cisplatin (P) versus observation (OBS) in completely resected (stage I-III) non-small-cell lung cancer (NSCLC) patients (pts): Final results after 70-month median follow-up. On behalf of the Adjuvant Navelbine International Trialist Association. // *J Clin Oncol.* – 2005. – Vol. 23. – P. 624s

Filipits M., Pirker R., Dunant A., et al. Cell Cycle Regulators and Outcome of Adjuvant Cisplatin-Based Chemotherapy in Completely Resected Non-Small-Cell Lung Cancer: The International Adjuvant Lung Cancer Trial Biologic Program // *J Clin Oncol.* – 2007. – Vol. 25. – P. 2735-2740.

Ikeda N, Nagase S, Ohiro T. Individualized adjuvant chemotherapy for surgically resected lung cancer and the roles of biomarkers // *Ann thorac cardiovasc surg.* – 2009. – Vol.15 №3. – P. 144-149.

Keller SM, Adak S, Wagner H, et al. A randomized trial of postoperative adjuvant therapy in patients with completely resected stage II or IIIa non-small-cell lung cancer. // *N Engl J Med.* – 2000. – Vol. 343. – P. 1217-22.

Scagliotti GV, Fossati R, Torri V, Crinò L, Giaccone G, et al. Randomized study of adjuvant chemotherapy for completely resected stage I, II, or IIIA non-small-cell lung cancer. // *J Natl Cancer Inst.* – 2003. – Vol. 95. – P. 1453–61.

Strauss GM, Herndon J, Maddaus MA, et al. Randomized clinical trial of adjuvant chemotherapy with paclitaxel and carboplatin following resection in stage IB non-small cell lung cancer (NSCLC): Report of Cancer and Leukemia Group B (CALGB) protocol 9633. // *J Clin Oncol.* – 2004. – Vol. 22. – P. 621s

Waller D, Peake MD, Stephens RJ, et al. Chemotherapy for patients with non-small cell lung cancer: the surgical setting of the Big Lung Trial. // *Eur J Cardiothorac Surg.* – 2004. – Vol. 26. – P. 173-82.

# CONTROL OF HINDMARSH-ROSE MODEL BY NONLINEAR-OPEN-PLUS-CLOSED-LOOP (NOPCL)

*Tounsia Benzekri, PhD*

University of Science and Technology Houari Boumediene,  
Faculty of mathematics, EL ALIA, Bab Ezzouar, Algiers, Algeria

---

## Abstract

In this work, we use the Nonlinear-Open-Plus-Closed-Loop (NOPCL) method to control a nonlinear model: the Hindmarsh-Rose model in which we can exhibit regular and chaotic dynamics. The aim of the NOPCL method is to entrain complex dynamics to arbitrary given goal dynamics, by adding a suitable control term to the system. We use this method to suppress chaos, by entraining chaotic dynamics to a periodic one for the Hindmarsh-Rose model.

---

**Keywords:** Control chaos, Hindmarsh-Rose model, nonlinear-open-plus-closed-loop

## Introduction:

There have been a great number of studies related to the control of nonlinear dynamical systems (For review see Refs.(1,2,3,4,5,6). These methods have been applied in a wide number of domains including physical and biological systems, robotics, avionics and many other.

Particularly there was a great deal of research to modeling and control mechanism of excitable biological media such as activity of neurons which exhibit chaotic behavior (e.g. Refs.(7,8,9).

The Hindmarsh-Rose model (HRM), which models a neuronal electrical activity, is a three-dimensional model capable of complex dynamics such as bursting oscillations and chaos. Neurons react on injection of a current by a quick, short depolarization of their membrane potential, which is negative in rest.

The activity of neurons consists of series of pulses, alternated by long periods of low activity around rest potential. This is known as an action potential, or spike.

Bursting oscillation is a time evolution consisting of bursts of rapid spikes, alternated by phases of relative quiescence. These series of pulses are considered to carry the information transmitted by neurons.

We use the NOPCL method to show how the Hindmarsh-Rose model can be controlled by driving its output to the desired pattern. The aim of this method is to add a control term, a driving term, to the initial system in order to drive its dynamics from one trajectory into another one. In particular, this method is able to switch chaotic dynamics into a periodic one and vice versa.

## Entrainment Control

Let us recall the Entrainment Control as explained in Refs.2.

We denote by  $u$  the additive control term, the controlled dynamical system is then given by:

$$\frac{dx}{dt} = F(x,t) + u(t) \quad (1)$$

The control problem is to find a control function  $u \in R^n$ , such that the system state  $x$  is entrained to arbitrary given goal dynamics  $g$  for which the error between  $x$  and  $g$  satisfies:

$$\lim_{t \rightarrow \infty} \|x(t) - g(t)\| = \lim_{t \rightarrow \infty} \|e(t)\| = 0 \quad (2)$$

The basin of entrainment associated with an appropriate time  $t_s$  and  $g$  is defined by:

$$BE(g, t_s) = \{x(t_s) / \lim_{t \rightarrow \infty} \|e(t)\| = 0\} \quad (3)$$

The goal is to show that the basin of entrainment is not an empty set, that is the error  $e = 0$  is asymptotically stable for the error equation, and is independent on the goal dynamics  $g$ .

### Open-Plus-Closed-Loop control (OPCL)

An (OPCL) strategy was first be proposed by Hubler and Luscher Refs.3 and extended by Jackson and Grosu Refs.2 to control the system (1). The proposed control term  $u$  is of the following form:

$$u(t) = S(t) \left\{ \left[ \frac{dg}{dt} - F(g, t) \right] - C(g, t)e(t) \right\}, \quad (4)$$

where the first term of  $u$  is called the Huble's open-loop interaction and  $S(t)$  is a suitable scalar switching function on time  $t_s$  satisfying:

$$S(t) = 0 \text{ for } t < t_s; \quad 0 < S(t) \leq 1 \text{ for } t \geq t_s. \quad (5)$$

The linear closed-loop interaction  $C(g, t)$  is given by:

$$C(g, t) = \frac{dF(g, t)}{dg} - A, \quad (6)$$

where  $A$  is an arbitrary matrix whose eigenvalues all have negative real parts.

Jackson and Grosu Refs.2 proved that if the function  $F$  is everywhere Lipschitz, with respect of  $x$ , then for an arbitrary smooth goal function  $g$ , the control  $u$  is such that none of basins of entrainment associated to  $g$  are empty sets.

Indeed, substituting equation (4) into the control system (1) and letting  $S(t) = 1$  yields to the given equation:

$$\frac{de}{dt} = F(e + g, t) - F(g, t) - \left[ \frac{dF(g, t)}{dg} - A \right]. \quad (7)$$

Expanding  $F(e + g, t)$  for small  $e$ , in the first order, yields the linear approximation equation:

$$\frac{de}{dt} = Ae. \quad (8)$$

Since all eigenvalues of the matrix  $A$  have negative real parts, the asymptotic stability of equation (8) is established.

However, it was shown by Y. Tian et al. Refs.4, that for a certain class of systems the basin of entrainment is rather complicated; it is dependent on the goal dynamics  $g$ .

### Nonlinear Open-Plus-Closed-Loop control (NOPCL)

The NOPCL control is based on the OPCL control. The control term  $u$  is reconsidered as follows:

$$u(t) = S(t) \left\{ \left[ \frac{dg}{dt} - F(g, t) \right] - C(g, t)e(t) - N(g, x, t) \right\}, \quad (9)$$

where  $C$  is as defined in (6) and  $A$  defined as previously. The nonlinear term  $N \in R^n$  is the closed-loop control action whose  $i$ th element  $N_i(g, x, t)$ , is given for sufficiently smooth  $F$ , by:

$$N_i(x, g, t) = \frac{1}{2!} \sum_{j,k=1}^n \frac{\partial^2 F_i(g, t)}{\partial g_j \partial g_k} e_j e_k + \frac{1}{3!} \sum_{j,k,l=1}^n \frac{\partial^3 F_i(g, t)}{\partial g_j \partial g_k \partial g_l} e_j e_k e_l + \dots + \frac{1}{m!} \sum_{j,k,\dots,p=1}^n \frac{\partial^m F_i(g, t)}{\partial g_j \partial g_k \dots \partial g_p} e_j e_k \dots e_p$$

$m \geq 2, \quad i = 1, 2, \dots, n$  (10)

where  $m$  is the order of derivative of  $F$  called the order of parameter of the function  $N$ .

In this case, expanding  $F(e + g, t)$ , for small  $e$ , one obtain:

$$\frac{de_i}{dt} = Ae_i + \frac{1}{(m+1)!} \sum_{j,k,\dots,p=1}^n \frac{\partial^{(m+1)} F_i(g, t)}{\partial g_j \partial g_k \dots \partial g_p} e_j e_k \dots e_p + \dots,$$

$i = 1, 2, \dots, n$  (11)

It is easily proven Refs.2 that the basins of entrainment are the whole phase space for systems for which the function  $F$  is polynomial of degree  $m$ ,  $m \geq 2$ . This is due to the fact that in this case, (11) will be reduced to (8), and  $e$  solved from this last equation approaches zero for all initial condition  $e(t_s)$ .

### Control of Hindmarsh-Rose Model

The Hindmarsh-Rose Model was developed by Hindmarsh and Rose (1984) to describe an isolated triggered burst of action potentials observed in a brain cell of a pond snail. The equations are given by:

$$\begin{aligned} \frac{dx}{dt} &= y - x^3 + 3x^2 - z \\ \frac{dy}{dt} &= 1 - 5x^2 - y \\ \frac{dz}{dt} &= \varepsilon(4x + K - z) \end{aligned}$$

(12)

where  $x$  is the membrane potential,  $y$  and  $z$  represent empirical variables describing the activation and inactivation of the ionics conductance. They describe respectively some fast and slow gating variables for ionics. Slow activation of  $z$  is due to the small parameter  $0 < \varepsilon \leq 1$ .

These equations model the electrical activity of the membrane potential of a single neuron. The external current  $K$  is viewed as a control parameter delaying and advancing the activation of the slow current in the model.

Notice that the system is autonome.

### Simulation results

In order to illustrate the effect of the driving term, we fix the parameter  $\varepsilon$  of the HRM to  $\varepsilon = 0.006$ .

For this system all the fourth order partial derivatives are equal to zero since the function  $F$  of HRM is a polynomial of degree 3. Notice that it is easy to see that the function  $F$  is everywhere Lipschitz.

The control parameter  $m$  is thus taken to be 3 in the NOPCL control.

It follows that the closed-loop control action  $N(g, x, t)$  is given by:

$$N(g, x, t) = [(-3g_1(t) + 3)e_1^2(t) - e_1^3(t), -5e_1^2, 0] \tag{13}$$

For convenience, the matrix  $A$  is taken diagonal and the linear closed loop interaction is given by:

$$C_1(g) = (-3g_1^2(t) + 6g_1(t))e_1(t) - e_2(t) - e_3(t), \tag{14}$$

$$C_2(g) = -10g_1(t)e_1(t) + (1 + a_{22})e_2(t), \quad (15)$$

$$C_3(g) = \varepsilon(4e_1(t) - (1 + a_{33})e_3(t)). \quad (16)$$

In our case, the purpose of the control action is to steer the Hindmarsh-Rose model from one of its trajectory to another one. Hence  $g(t)$  is such that

$$\frac{dg(t)}{dt} - F(g) = 0, \quad \forall t. \quad (17)$$

The control term  $u$  is then the sum of  $C(g)$  and  $N(g, x, t)$ .

The error equation is the same as in (8). Hence, for the Hindmarsh-Rose Model, the basin of entrainment  $BE(g)$  is global for all values of  $g$  and

$$e_i(t) = \exp(a_{ii}) \quad \text{for } i = 1, 2, 3 \quad (18)$$

For numerical analysis, we choose the matrix  $A$  as follows:

$$A = \text{diag}(-1, -1, -0.01) \quad (19)$$

The goal trajectory  $g(t)$  is a bursting periodic motion. Our aim is to steer the HRM from chaotic trajectory to bursting oscillating trajectory.

Numerical simulations shows that the solution turns out to be chaotic for the current  $K = 3.15867947$  and periodic for  $K = 5.1$ .

We depict, in respectively Figure1 and Figure2, the periodic bursting trajectory for  $K = 5.1$  and the chaotic trajectory for  $K = 3.15867947$  and initial conditions:  $(x(t_0), y(t_0), z(t_0)) = (-1.1804, -5.809943, 0.02212644)$ .

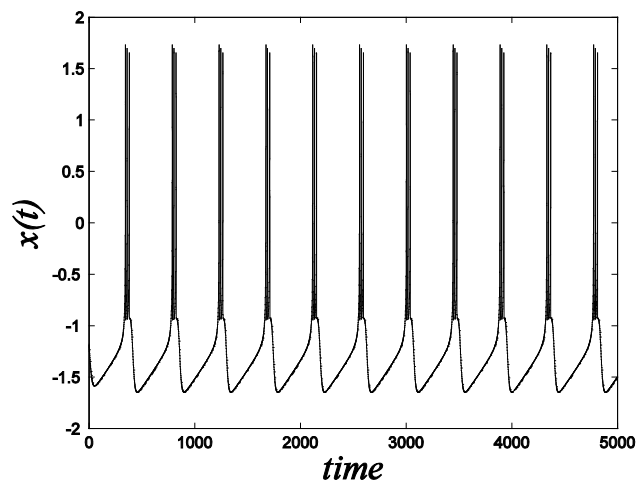

**Figure1. Bursting oscillations of the membrane potential  $x(t)$  for  $K = 5.1$  and initial condition  $(-1.1804, -5.809943, 0.02212644)$ .**

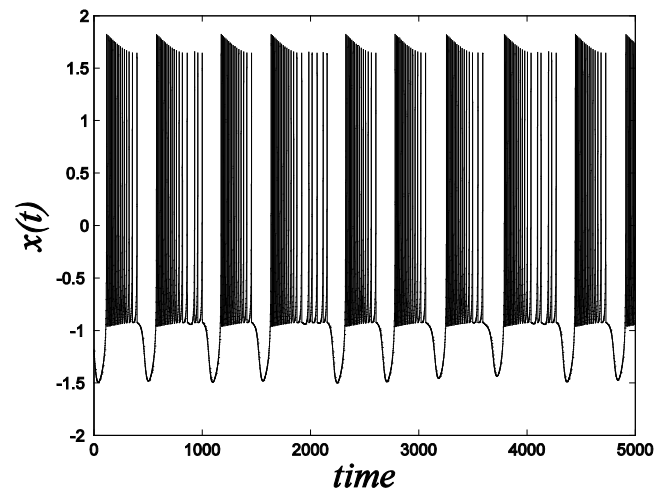

**Figure2.** Chaotic solution of the membrane potential  $x(t)$  for  $K = 3.15867947$  and initial condition  $(-1.1804, -5.809943, 0.02212644)$ .

Lyapunov exponents are used to describe the periodic and chaotic dynamics of nonlinear dynamical system.

The time varying largest Liapunov exponent, showing, for  $K = 3.15867947$  the chaotic motion, is represented in Figure3.

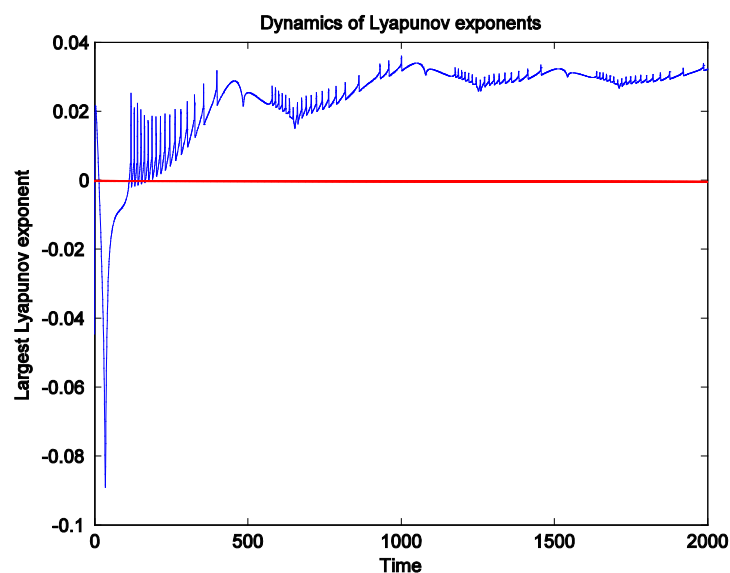

**Figure3.** The largest Lyapunov exponent for chaotic solution of HRM.

In order to avoid the transition phase of the trajectory, we start control of the chaotic motion at  $t_s = 1300s$  for the same initial condition as above.

We observe in Figure4 that at this time  $t_s$ , the trajectory is driven to the bursting trajectory, thus removing chaos.



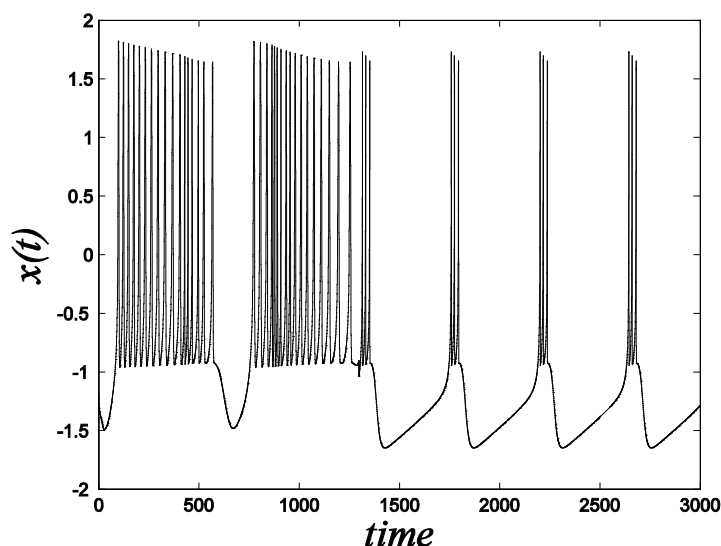

Figure4. The HRM driven from chaotic solution to bursting solution by adding the control term  $u$ .

### Conclusion:

We considered the Hindmarsh-Rose model. We have shown by using the NOPCL method that it is possible to switch from one trajectory of the system into another one and therefore changing the dynamics of the potential action.

The aim of this method is to add a suitable driving term to the HRM, which forces the controlled system to perform a motion which coincides with a target trajectory of the model. We showed that we can suppress the chaotic dynamics of the HRM.

### References:

- G.Chen, X.Dong, From Chaos to Order: Perspectives and Methodologies in Controlling chaotic Nonlinear Dynamics System, Int.J.Bifurcation Chaos, vol. 3, no. 6, 1993.
- E.A. Jackson, I.Grosu, An open-plus-closed-loop (OPCL) control of complex dynamic systems, Physica D, vol.85, 1993, pp. 1-9.
- A.Hubler, E. Luscher, Resonant stimulation and control of nonlinear oscillators, Naturwissenschaften, vol. 76, pp. 67-69.
- Yu-Chu. Tian, M.O. Tade, J.Y. Tang, Nonlinear open-plus-closed-loop (NOPCL) control of dynamic systems, Chaos Solitons and Fractals, vol. 11, no. 7, 1993, pp. 1029-1035.
- E.A. Jackson, OPCL migration controls between five attractors of the Chua system, Int.J.Bifurcation Chaos
- N. Nijmeijer, A.J. Van Der Schaft, Nonlinear Dynamical control Systems, Springer-Verlag, 1990.
- A.Garfinkel, M.L.Spano, W.L.Ditto, J.N.Weiss, Controlling cardiac chaos, Science vol.257, pp. 1230-1235, 1992.
- S.Rajasekar, Controlling of chaos by weak periodic perturbations in Duffing-van der Pol oscillator. Pramana J. Phys. vol.41, pp. 295-309, 1993.
- S.Rajasekar, M.Lakshmanan, Bifurcation, chaos and suppression of chaos in FitzHugh-Nagumo nerve conduction model equation, J Theor Biol., vol. 166, no.3, pp.275-88, 1994

# TEACHING MATHEMATICS WITH NEW TECHNOLOGIES, SOME PERCEPTIONS OF EFFECTIVENESS OF ICT USE IN MOROCCO

*Karima Hamdane*

*Mohamed Khaldi*

*Ali Bouzinab*

University Abdelmalek Essaadi, Tetouan, Morocco

---

## Abstract

Many countries are realizing the importance of equipping their educational institutions to the new technology of connection, information and communication. Connectivity provides many benefits, including access to an ever-growing volume of educational information, opportunities for collaboration and the use of online applications. In addition, it is important for students, as well as teachers, to learn information and communication technology (ICT) skills to enable them to participate in the evolving knowledge society. The Moroccan government is heavily investing in human and physical capital and has undertaken important regulatory reforms in order to introduce this tool in teaching. This paper highlights the efforts in this regard and describes some aspects of teaching mathematics using ICT, benefits and constraints and stakeholders who can promote the integration of this tool in the process of teaching and learning.

---

**Keywords:** Teaching mathematics, ICT, education, Morocco

## Introduction:

The development of the countries cannot be achieved without effective knowledge of science and mathematics. In recent years, new technology every day investing in the cultural and social aspects of our life: they are such a great vector of communication for business and a fundamental tool for research. It is for this reason that the education systems of countries that are concerned about their development put great importance on the study of mathematics. But the manner in which mathematics has been taught has caused many reticences among both students and teachers. The mathematics makes bad memory to the most of generations which studied with the rule, the compass and strenuous and repeated exercises. Actually, children require to see mathematics as tool of emergence and intelligence and not to reduce them under famous and classic words: true or false! The rapid development of information and communication technologies (ITC) requires their integration into the process of teaching and education (La Velle & Nichol, 2000; Lever-Duffy, McDonald, & Mizell, 2003). ICT has been found to be a very important step in education around the world. It can be used in the classrooms to make learning more fun and interesting and therefore more effective. There is potential with today's technologies to train teachers in high quality teaching skills even when they are in extreme rural conditions, unable to attend training sessions. Technologies can reach people that could not be reached before, and everyone in the education system benefits.

However, the effective integration of ICT into education and specially teaching mathematics resists against the integration of these new technologies (Askar & Usluel, 2002; Kilicman & al; 2010). The reasons for this resistance are many: lack of knowledge or skills in the use of these new technologies, difficulty to accept news working methods and sometimes even asserting the ineffectiveness of these technologies.

In addition, The ICT in education is subject to a number of recommendations for use by Moroccan Ministry of Education, a large amount of notes and articles they are dedicated. But what about the reality of their integration into normal educational practices, the brakes, levers and the actual distance between these tools, the teacher and the students who use them? It is in this global perspective that will fit any changes in teaching practices, and this state is reflected in a general way by the fear of change.

### **ICT programs in Morocco**

Despite its recent integration, ICT have had a significant impact on schools, on teaching and on learning. In point of fact, schools have similar needs to any small business and use the same kinds of computer software for such tasks as accounting, student absence control, communicating, document preparation and printing. Schools also use specialist software for tasks like timetabling, electronic reporting, behavior tracking and student profiling, monitoring attendance and library management. In a whole number of ways, then, ICT tools are proving indispensable in making school administration more efficient and responsive to community needs.

Facing the digital challenge, the Moroccan government is working to prepare a platform, leading a new policy with strategic goals for executing an intergovernmental network, support economy based on knowledge and innovation in Morocco, the development of human resources and infrastructure for use of Information and Communication Technology (United Nations, 2004).

This technological revolution in education certainly influences learning styles. This is one of the topics that formed the basis of the national strategy for the development of Information and Communication Technologies (ICT), in order to record improvements. In fact, in the recent years, the Ministry of National Education and Training, embarked on an ambitious program to the generalization of ICT into the education system. Which program is focused on three main objectives namely: infrastructure, training, and the development of content (GENIE Program MEN, 2006).

The first phase of the generalization of ICT (January, 2009) equipment has 1 878 establishments with 2 058 Multimedia rooms which are functional only in 1543. As for teacher training, this first phase has enabled 30 000 people to benefit. Also, following the evaluation of the first phase of deployment of GENIE strategy, a fourth axis linked to the development of practice he has been built to facilitate and accelerate the improvement of the quality of learning and teacher professional development, which will have some impact on the development of students' skills. The management of GENIE is placed on a steering committee chaired by the prime minister. A project team was created to follow the implementation of GENIE program. So, there are no major constraints facing Morocco, but the government is seeking innovative solutions and private-public partnerships to put in place the future pilot projects in the different priority themes. The government has to combine the efforts of all development shareholders to promote the active use of knowledge for development and to take advantage of ICTs to facilitate information sharing, communication, new applications of technology, and to foster democracy and moralization of public life using ICT as the major tool.

### **Place of computers in mathematics education**

The computer system provides access to information and also analyzes this information, but the computer can facilitate access to knowledge as a part of a learning process. The integration of this tool in the teaching - learning of mathematics transforms fundamentally mathematical activity.

Through a process of problem solving, modeling situations progressive learning demonstration, students can become aware the relevance of mathematics activities, identify a

problem and experimenting with examples, conjecture a result set form solution, monitor results and evaluate their applicability to the problem studied. The software tool thus proves an indispensable means to implement a real mathematical activity. It is important that the student knows distinguish between outcome within an experiment and a result established deductively in mathematics.

Indeed, it enables:

- Obtain a quick representation of a problem, a concept to make sense of it and to foster ownership by the student;
- To link different frameworks (algebraic, geometric ...) of the same concept or the same situation;
- To explore situations showing different configurations in dynamic manner;
- To speculate from interactive experimentation in studying a problem with open-ended questions or a certain complexity and conduct a verification;
- To work on solving problems from common situations,, if the calculations are long and complex;
- To expedite the verification of certain results.

### **Contribution of computers in teaching and learning**

The computer provides access to different methods, techniques, numerical computation, graphics representations, acquisition and processing of experimental data and the set of methods for production of documents. It is a tool for documentary research (online and offline resources, encyclopedias, CD-ROMs and cultural services, etc.); Self-learning (with screening assessment, response analysis, control corresponding to a real training analysis) and self-assessment: production of documents, e-mail exchanges, production of websites. It allows classes in a profound transformation of the pedagogical relationship (educational contract) teacher-student. For example, the projection of a document for the whole class makes possible a collective effort through appropriate software (word processing, spreadsheet, etc...) and can mediate the dual teacher-student relationship.

On another, and according to the author (Abouhanifa and al. 2008), should not believe that the use of ICT is the radical solution to various problems related to the teaching and learning of mathematics in secondary, such as no motivation of students, school failure, scholar abandonment decrease level of proficiency in mathematics, etc.. However, these tools can be a catalyst leading to the teacher gradually innovates in methods and approaches while adapting to student activities.

With the prospect of a better visibility of this type of work, we must study the testimonies of class, in order to get the issues underlying the effective integration of computers in the classroom. Therefore, to give some answers to questions like: How mathematics teachers can they take to help students succeed and to acquire new knowledge, skills, attitudes and knowledge to act? How to reflect the interests and personality of each? How to set up learning, specific and unique to each learner?

The use of computers in the teaching of mathematics is therefore falls within the scope of innovative practices (multidisciplinary, team work, cross repositories and content ...). It is an educational approach that gives teachers the opportunity to invest in multidisciplinary teams, is a source of mutual enrichment.

### **Conclusion:**

A majority of teachers are convinced of the important role played by the use of computers in the teaching of mathematics in the classroom, as it offers some interesting exploration opportunities in a variety of situations for the teacher , and students by bringing to

think about what he does ( real work). However, a number of barriers hinder the effective integration of computers in the classroom. Mention may be made in this regard: the degree of control of computers, computer hardware maintenance, control of appropriate software and factors related to the management of time and content. The sources of these difficulties from the lack of teacher training in this area, the lack of computers for students or no number for teachers, lack of time ( timetables charged , the risk of incomplete programs , ..) , lack of interest and willingness on the part of teachers. Pedagogical and technical support, availability of resources and teacher training are the major difficulty.

**References:**

- Abouhanifa S, Kabbaj M., Belmadani M., Khalfaoui M., Hanini M. (2008) TICE et mathématiques
- La Velle, L., & Nichol, J. (2000). Editorial: intelligent information and communications technology for education and training in the 21st century. *British Journal of Educational Technology*, 31(2), 99–107.
- Lever-Duffy, J., McDonald, J., & Mizell, A. (2003). *Teaching and learning with technology*. Boston: Pearson Education.
- Askar, P., & Usluel, Y. K. (2002). Perceptions of teachers about the characteristics of computers in the diffusion process of technology. *H. U. Journal of Education*, 22, 14–20.
- Baki, A. (2002). *Ogreten ve ogretenler icin bilgisayar destekli matematik*. Istanbul: Ceren ayincilik.
- Kilicman, A., Hassan, M.A., & Husain Said, S.K. (2010). Teaching and learning using mathematics software“*The New Challenge*”. *Proc. Social and Behavioral Sc.* , 8: 613-619.
- Nation Unies (2004) *Commission Économique pour l'Afrique*. Bureau de la CEA pour l'Afrique du nord (CEA-AN). Réunion Ad Hoc d'experts sur les perspectives à long terme du développement des infrastructures de télécommunications en Afrique du nord. Casablanca (Maroc). *Perspectives à long terme de développement des Infrastructures de Télécommunications En Afrique du Nord*.

# DESCRIPTION OF HARMONIC QUASICONFORMAL MAPPINGS

*Anila Duka, MA*

University "Ismail Qemali", Vlora, Albania

## Abstract

In this paper we will discuss harmonic functions, conformal mappings and quasiconformal mappings and their applications, ect. Which are more flexible than conformal mappings and this make them an easy tool. Conformal mappings degenerate when they are generalized with many variables, but quasiconformal mappings don't.

**Keywords:** Harmonic functions, quasiconformal mappings

## Introduction:

Harmonic functions are very important, let see them in detail.

## 1 Harmonic Functions

If a function  $f(z) = u(x, y) + iv(x, y)$  is analytic in a point  $z$ , then all derivatives of  $f$ :  $f'(z), f''(z), f'''(z), \dots$  are also analytic in  $z$ . [1] From this known fact we will say that all partial derivatives of real functions  $u(x, y)$  and  $v(x, y)$  are continuous in  $z$ . From the fact of continuity of partial derivatives we know that the mixed partial derivatives of second order are equal.

This last fact and the Cauchy- Riemann equations, can be used to demonstrate that is a connection between real and imaginary part of an analytic functions  $f(z) = u(x, y) + iv(x, y)$  and the partial derivatives of second order equations

$$\frac{\partial^2 \phi}{\partial x^2} + \frac{\partial^2 \phi}{\partial y^2} = 0.$$

This equation is one of the most famous in applied mathematics, it is known like Laplace's equations of two variables. The sum  $\frac{\partial^2 \phi}{\partial x^2} + \frac{\partial^2 \phi}{\partial y^2}$  of two partial derivatives of second order is determined from  $\nabla^2 \phi$  and is called the laplacian of  $\phi$ . The Laplace's equation can be writed  $\nabla^2 \phi = 0$ .

A solution  $\phi(x, y)$  of Laplace's equations in a domen  $D$  of the plane is called with a special name.

### Definition 1: Harmonic function

A function  $\phi$  of two variables  $x$  and  $y$  with real values that has partial derivatives of first and second order continuous in a domain  $D$  that satisfies the Laplace's equation is called harmonic on  $D$ .

### Theorem 1: Harmonic function

Suppose that the complex function  $f(z) = u(x, y) + iv(x, y)$  is analytic in a domain  $D$ . Than the functions  $u(x, y)$  dhe  $v(x, y)$  are harmonic in  $D$ .

### 1.1 The harmonic conjugate

If  $f(z) = u(x, y) + iv(x, y)$  is analytic in a domain  $D$ , then the functions  $u$  and  $v$  are also harmonic in the domain  $D$ . Suppose that  $u(x, y)$  is a real function which is harmonic in  $D$ . If

it is possible to find another real function  $v(x, y)$  such that  $u$  and  $v$  satisfies the Cauchy-Riemann's equations in this domain  $D$ , then the function  $v(x, y)$  is called the harmonic conjugate of  $u(x, y)$ . If we take the sum of this functions like  $u(x, y) + iv(x, y)$  we have a function  $f(z) = u(x, y) + iv(x, y)$ , which is analytic in the domain  $D$ .

Although most harmonic functions have harmonic conjugates, unfortunately this is not always the case. Interestingly, the existence or non-existence of a harmonic conjugate can depend on the underlying topology of its domain of definition. If the domain is simply connected, and so contains no holes, then one can always find a harmonic conjugate. On non-simply connected domains, there may not exist a single-valued harmonic conjugate to serve as the imaginary part of a complex function  $f(z)$ .

## 2 Conformal Mappings

A geometrical property enjoyed by all complex analytic functions is that, at non-critical points, they preserve angles, and therefore define conformal mappings. Conformality makes sense for any inner product space, although in practice one usually deals with Euclidean space equipped with the standard dot product. In the two-dimensional plane, we can assign a sign to the angle between two vectors, whereas in higher dimensions only the absolute value of the angle can be consistently defined.

### Definition 2.

A function  $g : R^n \rightarrow R^n$  is called conformal if it preserves angles. But what does it mean to "preserve angles"? In the Euclidean norm, the angle between two vectors is defined by their dot product. However, most analytic maps are nonlinear, and so will not map vectors to vectors since they will typically map straight lines to curves. However, if we interpret "angle" to mean the angle between two curves, as illustrated in

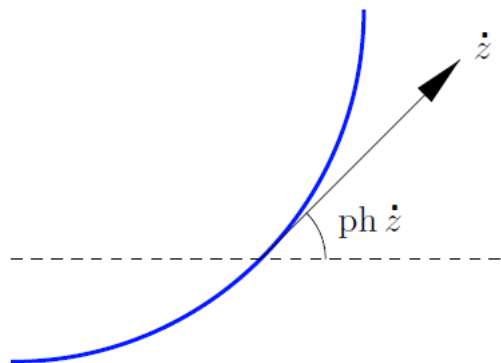

then we can make sense of the conformality requirement. Thus, in order to realize complex functions as conformal maps, we first need to understand their effect on curves.

In general, a curve  $C \in \mathbb{C}$  in the complex plane is parametrized by a complex-valued function  $z(t) = x(t) + iy(t)$ ,  $a \leq t \leq b$ , that depends on a real parameter  $t$ . Note that there is no essential difference between a complex curve and a real plane curve; we have merely switched from vector notation  $\mathbf{x}(t) = (x(t), y(t))$  to complex notation  $z(t) = x(t) + iy(t)$ .

If  $\zeta = g(z)$  is an analytic function and  $g'(z) \neq 0$ , then  $g$  defines a conformal map. One of the most useful consequences stems from the elementary observation that the composition of two complex functions is also a complex function. We re-interpret this operation as a complex change of variables, producing a conformal mapping that preserves angles. A conformal mapping, also called a conformal map, conformal transformation, angle-preserving transformation, or biholomorphic map, is a transformation  $w = f(z)$  that preserves local angles. An analytic function is conformal at any point where it has a nonzero

derivative. Conversely, any conformal mapping of a complex variable which has continuous partial derivatives is analytic. Conformal mapping is very important in complex analysis, as well as in many areas of physics and engineering.

A mapping that preserves the magnitude of angles, but not their orientation is called an isogonal mapping [2]. Conformal mappings can be effectively used for constructing solutions to the Laplace equation on complicated planar domains that appear in a wide range of physical problems, such as fluid flow, aerodynamics, thermomechanics, electrostatics, and elasticity. [3].

Quasiconformal mappings are generalizations of conformal mappings. [4] They can be considered not only on Riemann surfaces, but also on Riemannian manifolds in all dimensions, and even on arbitrary metric spaces. The importance of quasiconformal mappings in complex analysis was realized by Ahlfors and Teichmüller in the 1930s. Ahlfors used quasiconformal mappings in his geometric approach to Nevanlinna's value distribution theory. Teichmüller used quasiconformal mappings to measure a distance between two conformally inequivalent compact Riemann surfaces, starting what is now called Teichmüller theory.

There are three main definitions for quasiconformal mappings in Euclidean spaces: metric, geometric, and analytic. We give the metric definition, which is the easiest to state and which makes sense in arbitrary metric spaces. It describes the property that "infinitesimal balls are transformed to infinitesimal ellipsoids of bounded eccentricity".

Let  $f : X \rightarrow Y$  be a homeomorphism between two metric spaces. For  $x \in X$  and  $r > 0$  let

$$L_f(x, r) = \sup\{|f(x) - f(y)| : |x - y| \leq r\}$$

and

$$l_f(x, r) = \inf\{|f(x) - f(y)| : |x - y| \geq r\}.$$

(Here and later we use the Polish notation  $|a - b|$  for the distance in any metric space.) The ratio  $H_f(x, r) = L_f(x, r) / l_f(x, r)$  measures the eccentricity of the image of the ball  $B(x, r)$  under  $f$ . We say that  $f$  is  $H$ -quasiconformal,  $H \geq 1$ , if

$$\lim_{r \rightarrow 0} \sup H_f(x, r) \leq H \text{ for every } x \in X.$$

Homeomorphisms that are 1-quasiconformal between domains in  $R^2 = C$  are precisely the (complex analytic) conformal or anticonformal mappings, by a theorem of Menshov from 1937. Homeomorphisms that are 1-quasiconformal between domains in  $R^n$ ,  $n \geq 3$ , are precisely the Möbius transformations, or compositions of inversions on spheres in the one point compactification  $R^n \cup \{\infty\}$ , by the generalized Liouville theorem proved by Gehring and Reshetnyak in the 1960s. On the other hand, every diffeomorphism  $f : R \rightarrow R$  is 1-quasiconformal according to the metric definition, as is every homeomorphism between discrete spaces. Surely not all such mappings deserve to be called quasiconformal. [5]

### Conclusion:

1. The most common reason is that quasiconformal mappings are the generalization of conformal mappings.
2. We can see that many theorems of conformal mappings use only quasiconformality.
3. Quasiconformal mappings are more flexible than conformal mappings and this makes them an easy tool.
4. Quasiconformal mappings play an important role in some elliptic partial differential equations.
5. The extremal problems of quasiconformal mappings take to analytic functions related with regions or Riemann's surfaces. This was due to Teichmüller.
6. The problems of moduli were resolved with the help of quasiconformal mappings.
7. Conformal mappings degenerate when they are generalized with many variables, but quasiconformal mappings don't.



**References:**

A first course in complex analysis with applications / Dennis G. Zill, Patrick D. Shanahan (Churchill and Brown 1990, p. 241).

Harmonic and Quasiconformal Mappings. David Kalaj and Miodrag Mateljević (HQM2010), Proceedings of the ICM2010 Satellite Conference, J. Analysis, Volume 18 (2010), 239–260

[Juha Heinonen What is a conformal mapping?, Notices of the AMS, volume 53, Nr 11]

[L. V. AHLFORS, Lectures on quasiconformal mappings, University Lecture Series 38(2006), Amer. Math. Soc., Providence, RI]

# THE CULTURAL LANDSCAPE OF GEORGIA: FOR A PARTICULAR BORDERLINE OF THE GEORGIAN SITES SAFEGUARD

*Bianca Gioia Marino, Assistant Prof. PhD*  
DiArc\_University Federico II, Italy

---

## Abstract

As the UNESCO *Recommendation on the Historic Urban Landscape* (HUL) of 2011 states, the «urban heritage, including its tangible and intangible components» and it defines the historic urban landscape as an «urban area understood as the result of a historic layering of cultural and natural values and attributes, extending beyond the notion of “historic centre” or “ensemble” to include the broader urban context and its geographical setting». This definition «provides the basis for a comprehensive and integrated approach for the identification, assessment, conservation and management of historic urban landscapes within an overall sustainable development framework».

Since the concept of HUL is a ‘hub’ where many aspects and features are mixed and integrated, the Georgian landscape appears to be a significant and typical case: the Georgian culture is characterized by openness and continuous contacts with a lot of Greek, Roman, Iranian, Arabian, Russian and other cultures. This has given the Georgian landscape a specific identity and it offers to the same cultural landscape notion a challenge for his application and working out too (Cultural Landscape Convention, 2000).

The main purpose of contribution is about the complexity of the Georgian cultural heritage resources and the particular approach has to be applied in relation to the national cultural programs of conservation and valorization of the Georgian historic urban and natural landscape. This demonstrates that multidisciplinary approach is essential to obtain the conservation of identity and cultural values especially with reference to the management plans which must guarantee that the programs meet with success.

---

**Keywords:** Conservation, heritage, landscape, identity, authenticity

## Introduction:

Georgian country offers a double level of reflection: the former is about the abundance of tangible and cultural elements connoting Georgia and its places and culture; the latter concerns the multidimensional approaches which have to be followed in a heritage conservation program. From this point of view Georgia, and particularly, we can say, the Georgian landscape allows to have an interesting discussion table.

However, the conservation discipline, having the purpose to protect the cultural heritage, must include several other disciplines as well as history of architecture, planning, aesthetic, strengthening, economics, archeology, and so on. This shows us the multidisciplinary and, we have to say, the interdisciplinarity at the same time.

On the other side, we should remember that the concept of conservation and the way of restoring the cultural heritage change everywhere and they depend on the civilization which produced it in time.

The Georgian territory has been in antiquity a special connection between the Mediterranean coast due to the presence of the Black Sea. The site of Phasis (maybe the actual Poti and founded in the middle of the VI century b.C.) was the main connection point

between the West and the East, providing to develop the influence of the Caucasian and Scythian culture on the Western one.

This characteristic of simultaneous presence of different cultures represents the main peculiarity of the Georgian identity and actually it seems to be in a strong relationship with the global and general aims of the conservation culture that is linked to the present needs; in other words, the layered and historic Georgian context appears to be in concordance with the Proclamation of an international decade for the rapprochement of cultures (2012-2022) adopted by the General Assembly of ICOMOS in Paris in 2011.

At the present the Georgian country is facing a very significant economic and social development and several conservation programs, planning and new buildings are being realized. From this point of view we can note that the same historic urban landscape - as well as its natural one - is being changed and there is, we think, the real risk of losing its own identity. On the other hand the *Vienna Memorandum on World Heritage and Contemporary Architecture – Managing the Historic Urban Landscape* (2005) remarks that «Historic buildings, open spaces and contemporary architecture contribute significantly to the value of the city by branding the city's character. Contemporary architecture can be a strong competitive tool for cities as it attracts residents, tourists, and capital. Historic and contemporary architecture constitute an asset to local communities, which should serve educational purposes, leisure, tourism, and secure market value of properties» (art. 31).

Moreover, «the *Vienna Memorandum* focuses on the impact of contemporary development on the overall urban landscape of heritage significance, whereby the notion of historic urban landscape goes beyond traditional terms of “historic centres”, “ensembles” or “surroundings”, often used in charters and protection laws, to include the broader territorial and landscape context.».

However, we cannot disregard that there have been a lot of international meetings of experts – and we could cite some documents such as *Déclaration sur la conservation des paysages urbains historiques* (2005); the Round Table of Montréal (2006), *Declaration of Jerusalem* (2006); *Les villes entre Intégration et Désintégration* (ISoCaRP, 2006);

*Conclusions of Vilnius* (ICCROM, 2006) - that have remarked the need to join actions finalized to a sustainable urban (and social) development through the heritage conservation, detecting the direct link between development and preservation, enriching the latter with connotations related to socio-anthropological factors.

As matters stand the main question is: how could the multidisciplinary preserve and improve authenticity of the Georgian heritage identity?

### **From multidisciplinary to interdisciplinary. Heritage conservation and identity**

As it is well-known, the expanding notion of cultural heritage, in particular over the last decade, includes a broader interpretation leading to recognition of human coexistence with the territory and human beings in the social and anthropological context; this requires new approaches and methodologies for urban conservation and development in a land context.

However, to understand the essence of the “sense of place” that has to be considered in respecting cultural heritage, we could look at an image that shows us the character of a part of the historical and urban landscape.

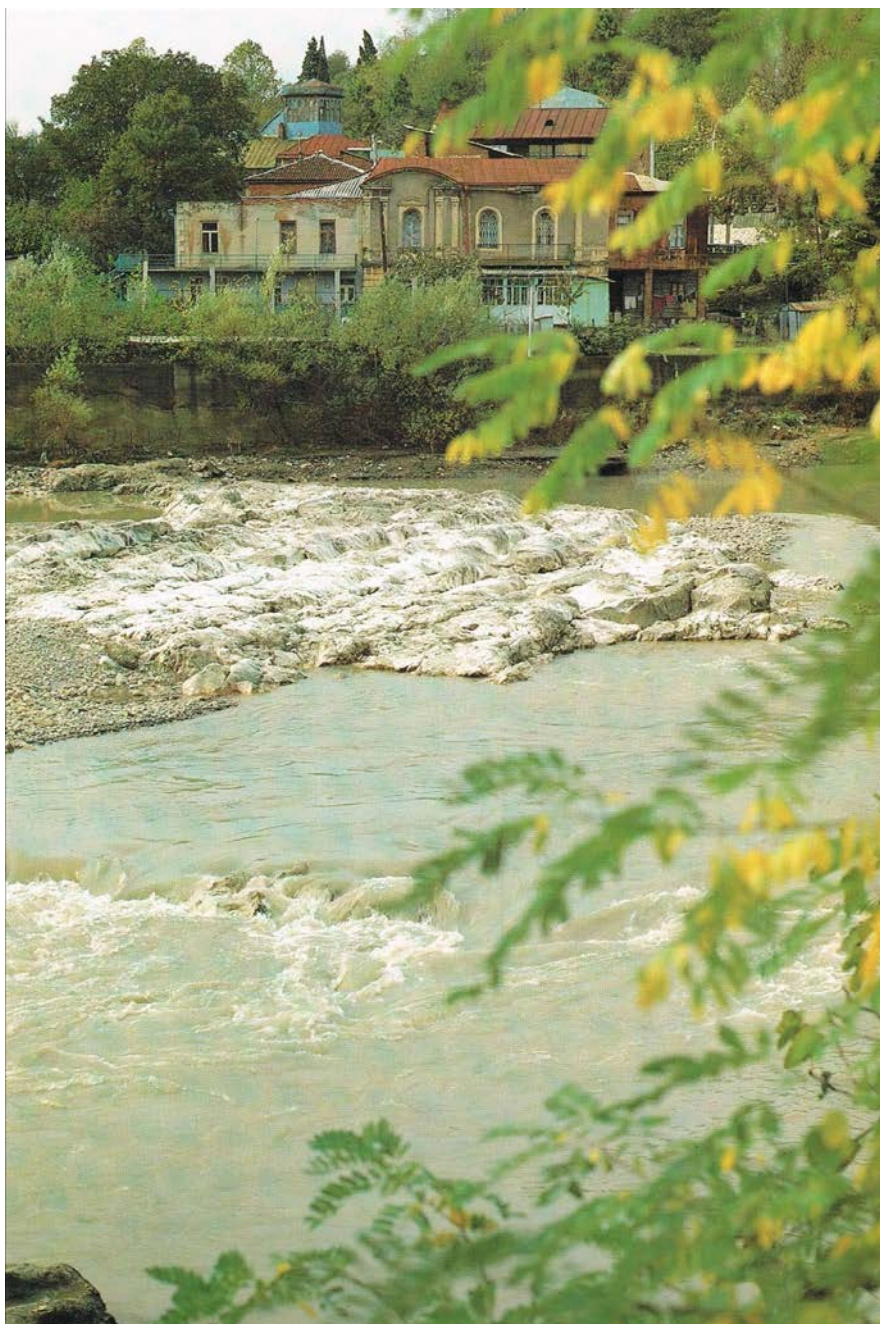

Fig. 1\_Kutaisi, Old buildings on the Rioni's left bank (Tamaz Gersamia, Kutaisi, 1990)

In any case, to explain this image and to bring out from it some tools to deepen our considerations we have to underline the Historic Urban Landscape significance.

Above all it is necessary to specify the concept of “spirit of place”. In fact, the typically physical aspects of the sites considered together with the immaterial ones has brought the evolution of the concept of heritage towards the connotation of a city that becomes real through a comprehensive idea within which the historical dynamics are especially important. In other words, with the passing of time it has become more and more concrete the cultural structure within which to insert the notion of “heritage”, and such a structure is based on “values” and “spirit of place”. In fact the Québec Declaration states that «Recognizing that the spirit of place is made up of tangible (sites, buildings, landscapes, routes, objects) as well as intangible elements (memories, narratives, written documents, festivals, commemorations, rituals, traditional knowledge, values, textures, colors, odors, etc.), which all significantly contribute to “make” the place and giving it spirit, we declare that intangible cultural heritage gives a richer and more complete meaning to heritage as a

whole and it must be taken into account in all legislation concerning cultural heritage, and in all conservation and restoration projects for monuments, sites, landscapes, routes and collections of objects». Moreover we have to interpret “spirit of place” as a relational concept, based on a plural and dynamic character which can possess multiple meanings and peculiarities, of changing through time, and of belonging to different groups.

It is useful to add that the Faro Convention of 2005, by directly linking heritage and human rights (“...reconnaître que le droit au patrimoine culturel est inhérent au droit de participer à la vie culturelle, tel que défini dans la Déclaration universelle des droits de l’homme”, art. 1) recognizes the public interest associated to the cultural patrimony (art. 5) and identifies its factors supporting human development (Section II).

But the most recent document which has faced the HUL notion is the *UNESCO Recommendation on the Historical Urban Landscape* of 2011. It states that the «urban heritage, including its tangible and intangible components, constitutes a key resource in enhancing the liveability of urban areas and fosters economic development and social cohesion in a changing global environment». It defines the historic urban landscape as an «urban area understood as the result of a historic layering of cultural and natural values and attributes, extending beyond the notion of “historic centre” or “ensemble” to include the broader urban context and its geographical setting». Moreover the Recommendation, going back to the 1976 “UNESCO Recommendation concerning the Safeguarding and Contemporary Role of Historic Areas”, defines the HUL as «ensembles of any group of buildings, structures and open spaces, in their natural and ecological context, including archaeological and palaeontological sites, constituting human settlements in an urban environment over a relevant period of time, the cohesion and value of which are recognized from the archaeological, architectural, prehistoric, historic, scientific, aesthetic, socio-cultural or ecological point of view. This landscape has shaped modern society and has great value for our understanding of how we live today». The multiple aspects that shape the urban landscape are evident.

From these few remarks it appears essential to start our analysis about the term “landscape”: it comes from the Dutch “landschap”: land as area that comes from the Basque word “landa” (labored earth); and “schap” corresponds to the term “ship”, that means “position held”.

Therefore, the word “landscape”, first recorded in 1598, was borrowed as a painters’ term from Dutch during the 16th century when they became masters of the landscape genre. But the artistic sense of “landschap” starts when it was brought into the English language, meaning a picture depicting scenery on land.

It can be interesting to refer to the origins of the term in the Arabic language: we are actually in a land/landscape that had a particular relationship also with the Mediterranean culture and this means that the values have to be compared with these aspects. The word landscape is represented by “manthar” or “mashhad” and they mean «that which is viewed, seen or witnessed» (Ch. Dabdoub-Nasser, 2012).

Nevertheless, we have to ask ourselves what are the current challenges for the concept “landscape” and how we can manage knowledge, interpretation and, finally, intervention. However, if we want to aim to safeguard identity and with it the authenticity of the places and heritage, we need to understand that to preserve them means to conserve the material. In fact, there is an important aspect which has to be considered: the relationship between the urban (and natural too) landscape with the material, the physical “material”.

So, before individuating interventions for a cultural landscape, I suppose that these ones are just a small series of elements for re-considering our concept of landscape.

In fact, the analysis of the transformation of this sort of concept allows us to think landscape as – we should say – a box of a lot of associations since we could say that landscape is a “place”. It concerns the relationships between ourselves and the external

physical context and every place can give us a series of material information which we interpret thanks to our cultural tradition and background.

However, landscape is a work of architecture in the sense of organization of space in shapes and functions. But, moreover landscape is a real document, because it witnesses history; it is an archive because it conserves past human life style, cultures, techniques and so on; it is a palimpsest because it represents a text where the transformations are visible and, more, the other ones are in progress.

It is the place where memory and present are really mixed; where intangible factors and physical elements show themselves together, each giving significances to the other.

All this lets us consider the complexity and also our boundaries of intervention on landscape. In the field of the discipline of conservation, knowledge, analysis and interventions are focused on the material. For this reason there are a lot of disciplines which allows us to determine its knowledge and, so, to choose a good action for the conservation. Nevertheless, we cannot consider material only from the scientific point of view. The scientific disciplines are not enough to preserve the identity of the cultural heritage: instead the criteria and also the aims of conservation drive us to ask ourselves about the esthetical and ontological essence of material/substance in the sense of its appearance as phenomena.

As the physician E.Mach underlined: «every physical phenomena is a psychological phenomena». This means that the physical phenomena, besides their scientific aspect, possess a substance that exists when the man observes them. In other words, the physical phenomena (and now we can say Nature as a whole) assume and show significances just when the subject or the witness looks at them.

Another relationship which is important for understanding the complexity and, more, the peculiarity of the Georgian heritage is represented by the one between material and nature. It is possible to grasp a deep connection between some typical Georgian buildings and their natural site. We can note a particular and singular aspect in traditional architecture: the constructions being at the ridge on the river seem to express the Georgian history and the experienced lives of the Georgian people. They seem to look at the nature which, through the river, flows as well as the history and the people who passed across this country giving the possibility to different cultures to trade and meet.



Fig. 2\_View of Tbilisi (Nino Laghidze, Georgian Architecture, 2009)

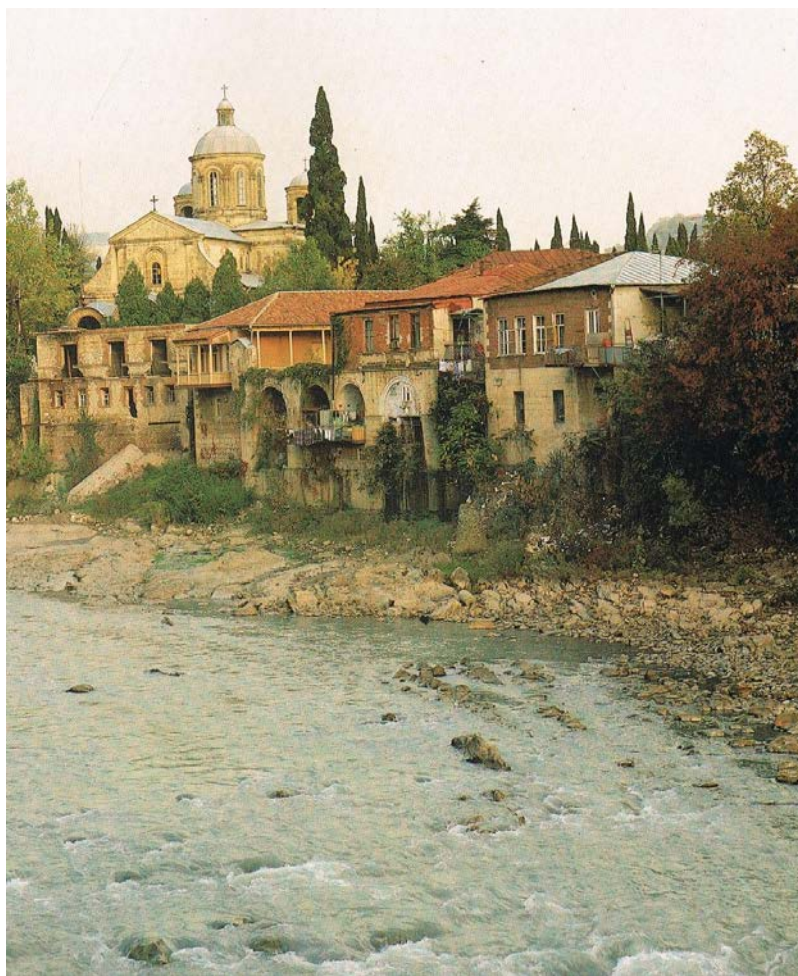

Fig 3\_ Fig. 1\_Kutaisi, Another view of the old buildings on the Rioni's left bank (Guram Pandzhikidze, Kutaisi, 1990)

We know that nature, through the natural interactions between the natural phenomena and the organic and inorganic elements and the transformation actions re-shapes and changes material; because of these above-mentioned transformations the subject perceives the sense of time and that causes the mechanism of the human memory.

On this point, we cannot forget to remark the contribution of the Brandi's theory: in the act of "recognition", which is an action of interpretation, we find a real theoretic instrument (linked also to the practice) to deepen the culture of preservation and restoration of architecture and landscape.

In fact, it represents a valid tool and a research field that might guarantee a fruitful path for the comprehension of the architectural work and site multidimensionality; and also, we have to say, it concurs to the recent changes in our current aesthetic conscience and perception. These are only a few aspects that have to be considered to avoid the loss of identity and authenticity, especially in the case of the complex Georgian heritage.

However, the aspect of the perception and interpretation of landscape is important to understand and detect the sense of landscape. We could try to define perception and its characteristics because the question is compulsory. In fact, we perceive our environment in a different manner in comparison with our forefathers, and perception is different for every civilization.

We can say that perception of natural landscape and architecture is based on three main aspects which we could compare with the (almost static) perception of works of art (T.Griffero, 2005): first, there is a psychophysical participation that drives the subject to "adapt" himself to the nature and landscape and to feel in joining with them; second, there is a fluidity, an

instability, an unsettled state that give us undetermined shapes and dynamic images linked to our state of mind and feelings; at last, there is a character of “surprise”, to say with Michel Dufrenne, there is a “persevering improvisation” that has the potential to go further the settled perceptive codes.

These issues drive us to reflect upon a persevering concept we find in the contemporary aesthetic thought: the “experience place”. This, together with the corporeality - which represents the “hub” of experience - consists of an emotional place, operative place and finally an intuitive place. They are strongly connected with each other and they do not admit any sort of unilaterality in thinking the landscape.

As matters stand we can very well understand the meaning of the terms “urban” and “historic”. It is not possible, when we debate on towns, to divide the two adjectives: they are integrated and shown in a whole through material and shapes, chromatism and atmosphere, places and real lives.

This drives us to recognize another element to be considered: the imagine of historic heritage and sites that local community, and not only that, possesses. This because of the idea of HUL takes substance and blends, integrated and overlapping, natural and built landscape, nature and historical transformation and community, to include in this sense an element belonging to the Georgian historical landscape, that is a sense of opening to the ‘other’, very visible within the contemporary urban scenario and mediated also by its historical views, that contribute to the formation of a collective memory of the idea of “landscape”.

In fact, we could maintain that the stratification of meanings, the one that shapes the spirit of the places represents the basis of the individual aesthetic experience and is aligned and stratified in turn with and within the collective memory. It is not a change if the perception of places as material and physical coagulation of factors, also intangible, arises also in the cultural research in the psychoanalytic field: in particular, the essence of architecture is investigated, or, if you want, the urban landscape, in connection with the mental work that guides and conditions perception itself. Even if, initially, it is recognized the practical component of the city, and the fact that modern disciplines keep into account, in the organization of life environments, ethological components and social samplings for a correct correspondence of planning to the needs of the community, we can note the missing of considerations of the effective psychic reality that guides any process of spaces apperception.

### **Conclusion:**

As we can see, the multidisciplinary on which the discipline of conservation is based, allows to integrate the scientific instruments we dispose with the unescapable action of interpretation of cultural values that, in the case of the Georgian sites, are complex and strongly linked to its peculiar identity.

All that suggests us to use a particular approach in relation to the national cultural programs of conservation and valorization, especially of the Georgian historic urban and natural landscape that can be a stimulant laboratory for the application of the more updated conservation philosophy.

In other words, the Georgian context represents a big challenge for a methodology, that starting from the concept of HUL which “also includes social and cultural practices and values, economic processes and the intangible dimensions of heritage as related to diversity and identity” could experiment the cross of different disciplines with the aim to conserve the spirit of openness to different cultures which have found place in this particular door of East.

For this we should speak in this case of inter-disciplinarity that allows a more dynamic and conscious approach not only to protect the cultural heritage in its identity, but also to guarantee an harmonious growth of the community in a long term time.



**References:**

- Bandarin, Francesco, and Ron, van Oers. *The Historic Urban Landscape. Managing heritage in a urban century*. Singapore: Wiley-Blackwell, 2012.
- Dabdoub-Nasser, Ch. *The concept of Landscape and its Interpretation in the Arabic Language*, Proceedings Euromed Heritage (Hammamet, 12-14 January 2012).
- Gersamia, Tamaz. *Kutaisi*. 1990
- Jokilehto, Jukka, and Cameron C., and Parent, Michel, and Petzet Michael (eds). *The World Heritage List. What is OUV? Defining the Outstanding Universal Value of Cultural World Heritage Properties*. Technical Report. Berlin: Hendrik Bäbeler Verlag, 2008.
- Marino, Bianca Gioia. *Restauro e Autenticità. Nodi e questioni critiche*. Napoli: Edizioni Scientifiche Italiane, 2006.
- Marino, Bianca Gioia. *Historic Urban Landscape and Conservation. Opportunities and Boundaries of a Notion for the Historic Town*. Napoli: Giannini Editore, 2012.
- Pepris, Alkiviades. *Protection and integrated conservation: rehabilitation policy. The paradigm of the city, Museum of Mtskheta (Georgia)*. Madrid: ICOMOS, 2002.
- Petzet, Michael. *Genius Loci. The Spirit of Monuments and Sites*. Proceedings 16th General Assembly of ICOMOS, Scientific Symposium, (Quebec, 30 September 2008).
- Spagnesi, Piero. *Geografia architettonica dell'antica Colchide fino al I secolo d.C.: Inside D'Acchille Tiziana*, ed. *Il vello d'oro. Antichi tesori della Georgia*. Roma: Palombi editori, 2011.
- Laghidze, Nino. *Georgian Architecture, Contemporary Georgian Architecture*. Tbilisi, 2009

# RELATIONS BETWEEN THE TRADITIONAL WOODEN SACRAL ARCHITECTURE OF THE PODHALE REGION AND CONTEMPORARY ARCHITECTURE OF CHURCHES

*Kinga Palus, Dr.*

Faculty of Architecture, Silesian University of Technology, Gliwice, Poland

---

## Abstract

The issues of building engineering in mountain regions, especially shaping sacral buildings over the centuries, beginning from traditional architecture of wooden Gothic churches to the churches built nowadays, form an interesting study topic. The Podhale region is both extremely difficult and interesting for modern authors of sacral architecture. The tradition of architectural works of wooden churches in Dębno, Obidowa, Grywałd and Harkłowa created certain unique models of churches integrated with the conditions of the mountainous climate and landscape aspects. The article aims to answer the author's following question: when designing contemporary sacral buildings in the Podhale region are we to preserve the principles formed over the centuries, following the regional tradition of wooden Gothic churches or ones strictly connected with the style of Witkiewicz architecture, or shall we make attempts at their contemporary interpretation, at the same time preserving universal values so as not to lose the regional identity - continuity of tradition, which currently seems to be a signal of a crisis of our civilization?

---

**Keywords:** Cultural heritage, tradition, contemporaneity, cultural region, architectural region

## Introduction:

The Podhale region is an interesting study field from a scientific point of view. The author became interested in taking up the topic after multiple trips to the Podhale region during which she had an opportunity to get to know the buildings personally and realize that Podhale, thanks to the specificity of the place, developed as a result of an evolutionary process patterns worth analyzing. Direct observation of spatial structure in the open area - the layout of projections, architectural forms and components, used building materials, construction solutions and details, made it possible to determine the features of building sacral architecture objects in the Podhale region.

The study is supported by stock-taking methods (photography and drawings) of individual buildings as well as archive studies. They made it possible to achieve a picture of sacral architecture over the centuries until the times of churches built nowadays. The interest in the past and the need to have an esteemed past in the degrading world space are very important and worth studying. Those issues analysed as parts of a system of persistence mechanisms will enable us to confirm that the past exists in the present and is even sometimes partly revived in the present times. Modernity is thus a modification of a thing that existed earlier. It shows up and regenerates as a novelty in the context of a more permanent thing.

The study includes wooden churches beginning from the 19th century throughout the 20th century (brick architecture), in reference to the sacral architecture of the beginning of the 15th century - a group of so-called 'late-Gothic' churches.

The main study purpose was to gather, order and systematise the knowledge about traditions of constructing churches over the centuries until the times of churches built nowadays (functional and spatial, construction and material solutions as well as types

of detail). An insightful study process was aimed to answer the question: 'To what degree did the regional architecture of Podhale influence the contemporary-built churches?' The assumed research goal has had an influence on showing the relations between the wooden sacral architecture in the Podhale region and the contemporary architecture of brick churches.

### **Traditional wooden sacral architecture in the Podhale region**

The architecture of wooden sacral buildings from the 15th century is formed by a group of so-called 'Podhale churches' in Dębno, Harkłowa, Łopuszna and Grywałd, described as 'late-Gothic'. The churches built in this period in the Podhale region are characterised by homogeneity of architectural solutions, which include a set of elements shaping them as a characteristic 'alphabet' of the wooden sacral architecture.

The end of the 17th century finishes the development process of a wooden 'Gothic' church.

The next period brings a new model of a wooden church shaped in the spirit of baroque architecture (Pęksowy Brzyzek, Nowe Bystre).

The romantic and national trend, a so-called 'Zakopane style', whose creator was Stanisław Witkiewicz, represents buildings inspired by former folk architecture (a chapel on Kalatówki in Zakopane, a chapel in Jaszczurówka in Zakopane).

The years 1918-1939 resulted in creating the so-called 'second Zakopane style'. Between 1945-1957 a so-called 'new Zakopane style'<sup>12</sup> (Maria Leśniakowska) was born, which was continued in the contemporary architecture of wooden sacral buildings lasting until the 80s of the 20th century.

The 80s in the 20th century until the modern times has been a period of building brick churches.

The research material, which contains sacral architecture from the 15th century throughout the 19th and 20th centuries, includes the development of church building in the Podhale region (Brykowski Ryszard, 1981). Those years constitute a period of many transformations, changing styles and historical trends which brought about changes in the way of forming buildings in the aspect of architectural solutions, construction, material selection as well as details. Despite differences individual periods in the Podhale sacral architecture are connected by searching and referring to the regional tradition of former periods and a need to build sacral architecture objects in a spirit of continuity - 'following the tradition properly'.

Interesting attempts at connecting the Podhale building style with contemporaneity, their evolution and ways of connecting modern forms with the mountainous environment may be found in the architecture of sacral buildings in the Podhale region. The need to search for a relation to the context of the local architecture and to continue its features is a result of building traditions throughout the centuries, which was adjusted to the conditions of the surroundings. It will depend on future generations designers whether the tradition of the building style and detail selection will be lasting and respected or disrupted by introducing foreign elements.

### **Tradition continuity in contemporary brick sacral architecture in the Podhale region - an identity phenomenon**

In comparison with various tendencies and creative trends characteristic for Polish sacral architecture the picture of the Podhale churches seems to be interesting. In the Podhale region there is a large group of interesting contemporary examples of sacral architecture, not studied

---

<sup>12</sup> The term was used for the first time by Leśniakowska Maria, while ordering chronological issues connected with the Zakopane style. See Leśniakowska Maria, *Jan Koszczyk Witkiewicz (1881-1958) i styl zakopiański*, [in:] „*Stanisław Witkiewicz człowiek – artysta - myśliciel*” [“*Stanisław Witkiewicz man - the artist - the thinker*”], Materials of the Tatrzanie Museum Association named after Dr Tytus Chałubiński in Zakopane, vol. 2, editor Moździerz Zbigniew, 275-292.

so far, which are a symbol of the regional identity and landmarks in the deteriorating architectural space of the country. The place identity is a mixture of the place culture and tradition as well as the place canon resulting from the coexistence between the spirit of the place and the time (Zbigniew Myczkowski, 2003).

The contemporary sacral architecture in the Podhale region demonstrates a connection between properly understood architectural tradition and a natural process of development and progress, which means creative continuity.

### **Representative objects of contemporary sacral architecture in the Podhale region - representation of examples**

In the proposed combination of examples being representative objects of contemporary sacral architecture in the Podhale region only a criterion of diverse selection was taken into accounts as far as urban, architectural, construction, material, formal and decorative factors are concerned. The leading principle is a representation of different tendencies occurring within the whole phenomenon.

Table 1. A representation of examples of contemporary brick sacral architecture

	
<p>Photo 1. St. Cross Church, Zakopane Zamoyskiego St., designed by Witold Cęckiewicz, 1983 (photo by the author)</p>	<p>Photo 2. The Holy Heart of Jesus Christ Church, Bukowina Tatrzańska, designed by Wojciech Pietrzyk 1975-1994 (photo by the author)</p>
	
<p>Photo 3. God's Mercy Church on Chramcówki, Zakopane, designed by Janusz Ingarden, 1988-1991 (photo by the author)</p>	<p>Photo 4. God's Mother of the Miraculous Medallion on Olcza, designed by Tadeusz Gawłowski, 1981-1988 (photo by the author)</p>



Photo 5. The Transfiguration Church, Gliczarów, designed by Stanisław Tylka, 1976-1990 (photo by the author)



Photo 6. Salvatorians' Church at Bulwary Słowackiego, Antałówka, Zakopane, designed by Marian Dziewoński and Jerzy Haber, 1956-1968 (photo by the author)

The selected objects certainly do not represent the whole situation in the aspect of the respect for the tradition in contemporary sacral buildings in Podhale. Apart from the buildings, to which we may apply a criterion of creative inspiration by the local tradition in synthetically processed forms (the cultural factor; spiritual ties with the past; conservatism of the local society and designers), there also exist, unfortunately, buildings difficult to accept, contrasting negatively with the Podhale landscape, whose solutions refer to the tradition

in a less successful way, e.g. the church in Gliczarów (photo 5) as a direct reference to the tradition (unconscious use of traditional models, faint architectural ingenuity reduced to repetition, a lack of interpretation, automation).

### **Application of new materials**

In contemporary architecture from Podhale timber is still being used but on a much smaller scale. Timber as the material used to build the whole structure (walls construction, elements of details) has been abandoned and new solutions have been introduced in which timber, however, plays a significant role (e.g. constructions glued together). In churches built in the half of the 20th century there are no examples of framework structure, apart from Gliczarów (photo 5), where it was used in upper parts of the frame, the lower ones were built with stone.

At present timber is usually used for fittings in sacral interiors constituting a decorative element. The external structure of the form of Salvatorians' Church on Antałówka in Zakopane (photo 6), built by means of the traditional technology, was completed by boarding with an application of boards in a vertical arrangement. The tower placed asymmetrically to the church front and a fragment of the aisle with presbytery were covered with shingle. The form of the church's mass refers to the regional tradition and is additionally intensified by the used local material and the character of the interior.

In Bukowina Tatrzańska (photo 2), in the church on Olcza (photo 4), timber played a role in covering steel or reinforced concrete construction of roofs, vaults, ceilings and walls. It is laid in the form of vertical, horizontal or herringbone patterns. Traditional wooden structures, because of different barriers resulting from changing dimensions of buildings, have been eliminated and replaced by modern technologies. Using local, natural building material as the native material together with application of new construction possibilities constitutes a unique connection between tradition and modernity - a harmonious and creative dialogue of the past and contemporaneity. Despite a great amount of new building materials available

on the market it is difficult to find the ones which would refer to a roof covered with shingle and changing with the time flow.

### **Architectural details**

Architectural details also underwent changes together with transformations in spatial structure (the projection layout, architectural form) as well as material and construction solutions. Nowadays they are transposed, bear hallmarks of interpreted tradition, simplified and modernised as a result of more perfect carpentry construction methods and modern building materials. They are visible both outside and inside a building in the form of Podhale motifs or taken directly from the Witkiewicz style. The attention is drawn to such elements as: 'the rising sun motif' occurring in fronts' gables, characteristic dowelling on the surfaces of doors and door as well as window trims. Roofs are still decorated with vertical wooden ornament placed on extreme ends of a roof ridge so-called in Polish 'pazdur' shaped as a tulip or lily flower and so-called in Polish 'rysie' the beams supporting eaves, made as elements processed in a different scale or material. One of the elements taken from the tradition, but used on a smaller scale in contemporary sacral architecture is also a cross beam performing solely a decorative and not a construction role, characteristic for the traditional wooden sacral architecture.

Conscious continuity of former cultural traditions is visible in the examples of architectural details used nowadays.

### **Conclusion:**

It is difficult to find in the contemporary building style a kind of architecture expressing a connection with the place, culture and tradition of a given region. Most newly designed buildings, among them sacral ones, could be situated in any place. The situation is different in the Podhale region, where a living tradition of the Podhale style and carpentry has been established. The regional style represents a culture of forms and techniques suitable for a given region, in concordance with the prevailing climate, material and topographic conditions. Its character and aesthetics come into being thanks to infinitely diverse, intelligent repetition of the basic formal and typological repertoire subject to constant adaptations. Contemporary churches in Podhale demonstrate features which allow us to classify them as solutions attempting to continue local architecture motifs. Traditionalism ensures the permanence of these forms and their application. The continuity of regional architecture consists in using the architectural language of former periods in contemporary times as well.

### **References:**

Ryszard Brykowski: *Drewniana architektura kościelna w Małopolsce XV wieku* [Wooden church architecture in the fifteenth century in Galicia], Wrocław [i in.]: Zakład Narodowy im. Ossolińskich, (Polska Akademia Nauk – Instytut Sztuki) [Department of National Ossolińskich, Polish Academy of Sciences - Institute of Art], 1981.

Brykowski Ryszard., Kornecki Marian: *Kościół drewniane w Małopolsce Południowej* [Wooden churches in the Southern Galicia], Wrocław [i in.]: Zakład Narodowy im. Ossolińskich [Department of National Ossolińskich, Polish Academy of Sciences - Institute of Art], 1984.

Cęckiewicz Witold Aleksander: *Tradycja i sacrum w architekturze. Współczesna interpretacja* [Tradition and sacred in architecture. Contemporary interpretation], In: „Udział pracowników Politechniki Krakowskiej w życiu kościoła katolickiego, za pontyfikatu Jana Pawła II” [The share of workers Cracow University of Technology in the life of the Catholic Church during the pontificate of John Paul II], Kraków, Wyd. Politechniki Krakowskiej, Ed. Cracow University of Technology 1998, 129-132.

Krakowska Karta Architektury Regionalnej [Cracow Charter of Regional Architecture] 1986, In: Rączka Jan Władysław, Regionalizm krakowski czyli uwagi o tożsamości „krakowskiej szkoły architektury” [Regionalism Cracow that is because of the identity of the "Cracow School of Architecture"], Cracow, 1994.

Kucza – Kuczyński Konrad: Nowe kościoły w Polsce [New churches in Poland], Instytut Wydawniczy Pax [University Press Pax], Warsaw, 1991, chapter 31, 36.

Leśniakowska Maria: Jan Koszczyc Witkiewicz (1881-1958) i styl zakopiański. [Jan Koszczyc Witkiewicz (1881-1958) and the Zakopane style], In: „Stanisław Witkiewicz człowiek – artysta - myśliciel” [Stanisław Witkiewicz man - the artist - the thinker], Materiały Towarzystwa Muzeum Tatrzańskiego im. dra Tytusa Chałubińskiego w Zakopanem, vol. 2, pod red. Możdzierz Zbigniew [Materials of the Tatrzańskie Museum Association named after Dr Tytus Chałubiński in Zakopane, vol. 2, editor Możdzierz Zbigniew], 275-292.

Myczkowski Zbigniew: Krajobraz wyrazem tożsamości w wybranych obszarach chronionych w Polsce [Landscape expression of identity in selected protected areas in Poland], Monografia 285. Kraków: Politechnika Krakowska im. Tadeusza Kościuszki, 2003, [Monograph 285. Cracow: The Cracow University of Technology], page 12, 85.

Norberg - Schulz Christian: Genius Loci. Towards a Phenomenology of Architecture. Rizzoli, 1984.

Węclawowicz – Gyurkovich Ewa: Współczesna architektura regionalna. [Contemporary Regional Architecture], In: Teka 2 Architektury Współczesnej Ziem Górskich. [Publication 2 Contemporary Architecture in Mountain Regions], Praca zbiorowa pod redakcją Szafera Tadeusza Przemysława. Kraków: Oficyna Wydawnicza „SEZ.ON” [Edited by Tadeusz Przemysław Szafer. Cracow: Publishing House "SEZ.ON"], 1996, 43-49.

Wroński Józef Szymon: Architektura nowo zbudowanych kościołów w Zakopanem. Próba charakterystyki [Architecture of modern churches in Zakopane. Characteristic], In: 150 lat organizacji parafialnej w Zakopanem 1847 – 1997 [150 years of the parish organizations in Zakopane 1847 – 1997], Materiały z Sympozjum Zakopane, 24 – 25 października 1997, pod red. Mieczysława Rokosza. Materiały Towarzystwa Muzeum Tatrzańskiego im. dra Tytusa Chałubińskiego w Zakopanem, Vol. 3. Kraków: Wyd. Św. Stanisława BM Archidiecezji Krakowskiej [Proceedings of the Symposium Zakopane, 24 - 25 October 1997, Materials of the Tatrzańskie Museum Association named after Dr Tytus Chałubiński in Zakopane, Vol. 3, editor Mieczysław Rokosz], Cracow 1998, 187-208.

# INCREASING THE CARRYING CAPACITY OF REINFORCED CONCRETE DRIVEN PILES BY CHANGING THEIR CROSS SECTIONAL GEOMETRY

*Assist. Prof. Ala'a M. Darwish*

Building and Construction Engineering Faculty, University of Technology, Baghdad, Iraq

---

## Abstract

The ultimate carrying capacity of a reinforced concrete driven pile is mainly obtained by calculating the product of its surface area multiplied by the adhesion stress between its shaft and the surrounding soil. For a certain type of soil its average frictional stress with concrete surfaces is taken equal to its value at mid depth of the pile. The surface area of a pile is the product of its cross sectional circumference multiplied by its length.

Through this study it was shown that the circumference of a circular cross section is less by 13% compared to the circumference of an equivalent area square section.

A suggested star cross section has been investigated; it was shown that it has an increase of 25% in its circumference compared to a square cross section having a similar area.

By adapting the suggested star shape cross section driven pile, it is believed that its carrying capacity will be more than that of a square cross section pile by 25%. In other words; to develop the same required carrying capacity of a group of piles, the suggested star shape cross section driven piles can be driven to four fifths of the required depth of the current similar area square cross sectional piles.

---

**Keywords:** Driven pile geometry, driven pile cross section, driven pile depth, star cross section pile

## Introduction

The purpose of any foundation is to transmit loads to the ground without excessive settlement. A piled foundation is used mainly where it is necessary to distribute the load to an underlying weak soil layer or to tie the load to firm strata through a layer of compressible material or water. In a typical case the decision to use piling would be made if the site investigation and/or design calculation showed that any other type of foundation will not be sufficient.

Piles may be classified by their manner of installation. Those which displace the soil to accommodate the volume of the pile are called displacement piles or simply as driven piles, while those in which the soil is removed and the void formed is occupied by the pile are called non- displacement piles or simply as bored piles.

Due to drilling machines which normally use helical drills, all bored piles are constructed to have circular cross sections. Bearing capacity of bored piles are determined by the related design formulae, and this type of piling will be out of the scope of this paper just because it is difficult to change their cross sectional geometry.

A wooden, steel or reinforced Pile having different cross sectional areas along its depth is termed as Tapered pile. {1} Such piles have their own equations to determine their carrying capacities and they will also be out of the scope of this paper.

The actual method of installing driven piles might be by the blows of a hammer, by vibration or pressure from a jack, the choice being determined by the type of pile, the ground condition and the circumstances of the situation. The essential feature of such piles is the



disturbed soil remains in contact with the surface of the newly introduced pile and there is an initial state of stress between the surface of the pile and the surrounding soil resulting from the process of installation.

Suitable cross-section such as square, hexagonal, rectangular or circular was used all around the world. In Iraq, pre cast reinforced concrete piles having square cross sections are often used in deep beds of soft to medium clay and silt that have a limited percentage of sand or gravel. The pile is supported in this case mainly by adhesion and to some extent by frictional action to the soil on the surface of the pile shaft. Such piles are termed friction piles. {2} in firm sands and gravel, end bearing can provide a considerable part of the total resistance, loose sand may provide less bearing, hard clay may provide considerable point resistance, and soft clay practically non.

### Carrying Capacity Of Driven Piles

In general, {3}, {4} the failure load  $Q$  of a pre cast reinforced concrete driven pile in cohesive soils can be determined by the following formula:

Failure load  $Q =$  Load carried on shaft+ Load carried by base+ Self-weight of pile

$$Q = C_a \times A_s + N_c \times A \times C_u + \gamma \times D \times A$$

Where  $C_a =$  average adhesion between shaft and clay,  $A_s =$  surface area of pile shaft,  $N_c =$  bearing capacity factor,  $A =$  area of base of pile,  $C_u =$  un-drained shear strength at pile base,  $\gamma =$  bulk density of clay and  $D =$  depth to base of pile.

The weight of the pile is approximately equal to ( $\gamma \times D \times A$ ). Thus, the surface applied load,  $P_f$  causing failure of the pile is given by:

$$P_f = C_a \times A_s + N_c \times A \times C_u$$

For deep soil layers mixed of silt and clay - as in the case of Iraqi soil - the end bearing capacity will be negligible. Therefore, the failure load of a driven pile could be determined by:

$$P_f = C_a \times A_s$$

The factor  $C_a$  - which represent the adhesion between pile shaft and clay- is constant for a given soil properties, then the major remaining factor determining the carrying capacity of a driven pile is its surface area. The surface area of any pile is calculated by multiplying its circumferential length by its depth. Therefore, there is a direct relation between a pile carrying capacity and both of its circumference and its length.

### Geometrical Calculation

All square cross section driven piles are pre-casted. Therefore, its cross section can be easily changed according to the designer will and that can be simply done by changing its casting moulds.

The typical used sizes- measured in centimeters- are: 28×28, 40× 40 and 50×50. The area of a square cross section pile having a side length of 28cm is 784cm<sup>2</sup> and its circumference is 112cm. While an equivalent area of a circular cross section will produce a diameter of 31.6cm and will give a circumference of 99.25cm. This means that the circular cross section when used for piling will reduce the carrying capacity of the pile by 11.4% compared with a square cross section pile having the same quantity of reinforced concrete. In other words, if the efficiency of a square cross section pile is 100% the equivalent circular cross section pile will carry only 88.6% compared to it. In spite of the long circumference of rectangular cross section driven piles it is not recommended to use such piles just because of their unequal transverse rigidity which inferiors their resistance to handling, driving and structural loading. The properties of Hexagonal cross section driven piles are considered as a combination of the properties of square and circular cross sections.

Based upon the above mathematical facts a Star cross section pile as shown in Fig 1 will be investigated.

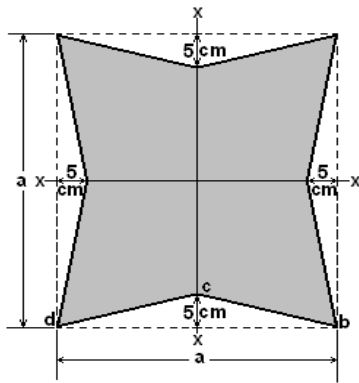

Fig 1 Star shape geometry

The star shape is a modification of a square having a cleavage at each of its four sides. For an equivalent star shape with a square cross section having a side length of 28cm, the proposed cleavage depth is 5cm.

To calculate the properties of the star shape cross section the length of its side (a) can be determined by taking into account that its area is equal to a square having an area of 784 cm<sup>2</sup>.

$$a^2 = 784 + 4 \times 5 \times \frac{a}{2} \Rightarrow a = 33.44 \text{ cm}$$

For calculating its circumference;

$$cb = \sqrt{5^2 + \left(\frac{a}{2}\right)^2} \Rightarrow cb = 17.44 \text{ cm}$$

Then its circumference is = 8 x 17.44 = 139.6cm

To calculate its moment of inertia about x-x axis:

$$I_{xx} = \frac{33.44^4}{12} - 2 \left[ \frac{33.44 \times 5^3}{36} + 33.44 \times \frac{5}{2} \left( \frac{33.44}{2} - \frac{5}{3} \right)^2 \right] - 4 \left[ \frac{5 \times \left( \frac{33.44}{2} \right)^3}{36} + \frac{33.44}{2} \times \frac{5}{2} \times \left( \frac{1}{3} \times \frac{33.44}{2} \right)^2 \right] \Rightarrow I_{xx} = 58320 \text{ cm}^4$$

The above calculation which is tabulated in table 1 below shows that the star shape have the longest circumference of 140cm compared to 112cm for the square section, while the circular section gets the shortest circumference of 99.25cm.

This means that the comparison between the surface area of piles having the same cross sectional area, but with different geometries will yield to the following:

Table 1 Comparison between the properties of different geometrical cross sections

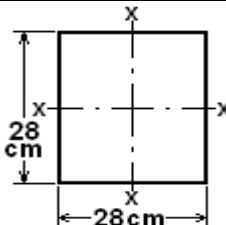
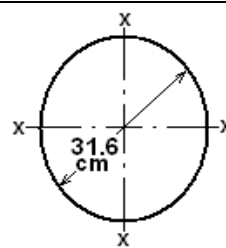
Cross sectional geometry	Area	Circumferenc e	Circumferenc e %	Moment of Inertia I <sub>xx</sub>	Moment of Inertia I <sub>xx</sub> %
 <p>Square</p>	784cm <sup>2</sup>	112cm	100%	51,221cm <sup>4</sup>	100%
 <p>Circular</p>	784cm <sup>2</sup>	99.25 cm	88.6%	48,966 cm <sup>4</sup>	95.6%

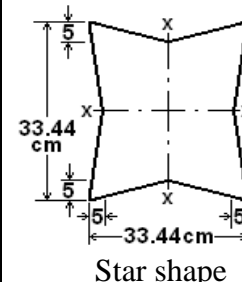
	$78.4 \text{ cm}$	$140 \text{ cm}$	$125\%$	$58,320 \text{ cm}^4$	$114\%$
---	-------------------	------------------	---------	-----------------------	---------

If the circumference of a square pile is considered to have 100% then the star shape pile will be 125%, while the circular one will get only 88.6%.

{5} by using the following formulas for calculating the moment of inertia for each of the three shapes about an axis passing through their Centroid,  $bh^3/12$  for the square,  $bh^3/36$  for the triangle and  $\Pi d^4/64$  for the circle, the calculation yield that: the star shape is higher than the square by 14%, while the circular is less than the square by 4.4%.

**Pile Reinforcement**

Normally a square cross section driven pile is reinforced by 4Φ16mm steel bars in addition to Φ8mm ties spaced at 150mm c/c. This will give a main reinforcement area of 800mm<sup>2</sup>. Current codes of practice require using a minimum of 6Φ16mm bars in addition to Φ8mm spiral spaced at 80mm c/c between its loops to reinforce Circular cross section driven piles. This will give a main reinforcement area of 1200mm<sup>2</sup>. Fig 2 shows the suggested steel reinforcement detail for the three pile types. It can be noticed that the square and the star shape can be used with less amount of steel reinforcement compared to circular cross section piles.

Concrete cover is increased around the main reinforcement of a star shape but it is reduced – for the ties only- especially near the sides necking. {6} for precast concrete that expected to be exposed to earth- as in our case- the minimum cover should not be less than 1.25in (32mm) if bars #5 (16mm) are going to be used. Fig 2 shows that the available cover for certain parts of the ties is 27.5mm which is less than the required minimum of 32mm. Taking into account that the main reinforcement will be well protected and the structural action of the ties will not be affected, this violation can be skipped by using proper water proofing coatings.

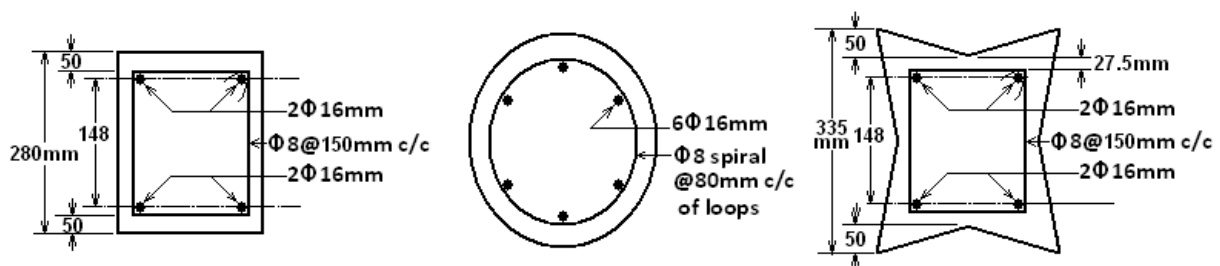

Fig 2 Reinforcement of Square, Circular and Star shape piles

**Discusion**

The previous calculation shows that a pile having a star shape cross section is expected to have more contact area with the surrounding soil. The failure surface is expected to be directly along the contact of the concrete surface and the surrounding soil as shown in Fig 3 and this was considered as a base for the calculation. It might be along the third possible surface which is a square of a side length of 335mm or in between the previous two possibilities. In all cases the star shape will have more contact area than a normal equivalent area square section.

Taking into account that the ultimate carrying capacity of a driven pile is evaluated by finding the product of its surface area and its friction with soil which is constant for a certain soil, this will mean that by the same quantity of material a star shape pile will have 25% increase in its strength compared to a square section pile and an increase of 36% compared to a circular pile. In other words it is possible to use star shape driven piles having four fifths the length of square piles.

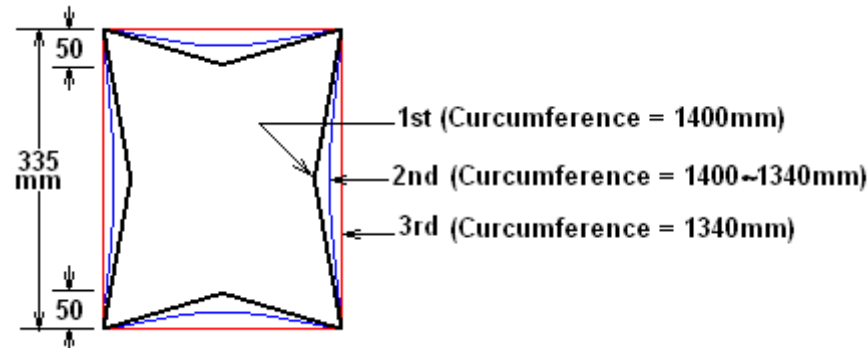

Fig 3 Expected possibilities of failure surface

## Conclusion

The following results have been reached:

- Circular cross section driven piles are less efficient by 11.4% in carrying capacity compared to square piles having the same cross sectional area.
- Square cross section driven piles are less efficient by 20% in carrying capacity compared to the suggested star shape cross sectional driven piles.
- The amount of increase of the carrying capacity of the suggested star shape driven pile is 25% more than that of the current square cross sectional piles.
- 20% of the length of a driven pile can be terminated if its cross section geometry was changed from the current square to the suggested star shape.

## References:

- J. S. Horvath and T. Trochalides, 'A Half Century of Tapered- Pile Usage at the JFK International Airport', 5<sup>th</sup> International Conference on Case Histories Geotechnical Engineering, New York, 2004.
- Foundation engineering, K.B.Woods et al, McGraw-Hill civil engineering series, Purdue University, Indiana, USA.1962.
- Pile design and construction rules of thumb, Ruwan Rajapakse, 2008.
- Tomlinson. M.J., Pile design and construction practice 3<sup>rd</sup> Ed. Viewpoint publication, Palladian publication Ltd. 1987.
- AISC 315-11B, Steel construction manual, fourteenth edition, USA, 2011.

# APPLIED THEATRE RESEARCH: DISCOURSES IN THE FIELD

*Prof. Rikke Gurgens Gjaerum*

Harstad University College, Norway

---

## Abstract

In this article, the author explores how discourses appear through the global field of 'Applied Theatre Research'. The study includes a discourse analysis of books on 'Applied Theatre' worldwide and articles, mainly published in *Applied Theatre Researcher* and *Research in Drama Education*, since the year 2000. The discourse study is also based on 23 interviews. The study shows us that Applied Theatre Research is a discursive global field build up by the following six main discourses: The legitimation discourse, the ethics discourse, the effect discourse, the outsider-visitor discourse, the global economy discourse and the aesthetic discourse.

---

**Keywords:** "Applied theatre research", discourse

## The study's background and research motivation

Applied Drama and Theatre is a relatively new field within theatre studies around the world. The term drew attention among theatre practitioners, facilitators and academics, all of whom looked beyond traditional theatre expressions in the late 1990s.<sup>13</sup> In 1999- 2000, the term Applied Theatre (AT) began to arise as an established term through the opening two research centres; Centre for Applied Theatre Research at The University of Manchester in the UK, and at Griffith University in Brisbane, Australia. Twelve years have passed since then. It is now interesting to look back and analyse the research field itself through a meta-study, in order to perhaps manage to clarify things and offer new ways of thinking about applied theatre as, an established field. What this article will explore, however, is how the diverse discourses appear through the first twelve years in the field of Applied Theatre Research (ATR). I must emphasize thought that the discourses I will briefly present is just a small part of a huge and highly diverse field, but my aim with this presentation is to give an overview of some of the central debates and discussions in the field of Applied Theater Research. The field is a conglomerate of educational-, political and aesthetical discussions, arguments and viewpoints. Discourse analysis therefor seems like a good methodological approach to this project. The study includes research from the US, Canada, Australia, Africa, Asia and Europe. Fifteen books on Applied Theatre worldwide, as well as 52 articles primarily published in *Applied Theatre Researcher* and *Research in Drama Education* since 2000 are used in this study together with research interviews of 23 researchers in 2010-2012.

Through this discourse study I have discovered six discourses in applied theatre research. The discourses seem to interconnect between many authors and projects in the ATR-field. After defining the sixth discourse all new articles I then read or interviews I did, could be categorized within this six discourses. The discourse journey then came to an end. The six discourses I will present in this article are:

---

<sup>13</sup> According to interviews with Nicholson, Thompson and Jackson, the term "Applied Theatre" somehow came into use during 1996-1999 at a conference during this period, though no one seemed to remember exactly when and by whom.

Discourses in ATR:	
<i>Gürgens Gjørum, 2012</i>	
1.	The legitimation discourse
2.	The ethics discourse
3.	The effect discourse
4.	The outsider-visitor discourse
5.	The global economy discourse
6.	The aesthetic discourse

These discourses can be understood as a constructed overview of the ATR from the late 90s until today. A similar overview of AT was made by Prendergast and Saxton in 2009. They attempted to define motifs in applied theatre art work, when summing up their text book *Applied Theatre: International case studies and challenges for practice*. By motifs they meant “/.../ distinctive ideas that recur as forms or shapes in the art form” (Prendergast, Saxton, 2009: 198). The four motifs they found central to all kind of applied theatre work was:

Motifs in AT:	
<i>Prendergast, Saxton, 2009: 187</i>	
1.	Participation
2.	Aesthetics
3.	Ethics
4.	Assessment

Prendergast and Saxton claim about their four selected motifs that:

/.../ most agree that these four areas are significant, there is often disagreement about who or what they represent in applied theatre and how to go about structuring the work in ways that address these issues (Prendergast, Saxton, 2009:187).

These significant four motifs in *applied theatre practise* are connected to the six discourses I have discovered in *applied theatre research*, the way I see it. In the two models above we see that the ‘discourses’ exceed the so-called ‘motifs’ by two more issues (economy and legitimation), the rest of the categories are approximately the same.

While the Prendergast and Saxton’s *motifs* are related to the art work itself, the *discourses* I have discovered merely arise from verbal discussions which are kind of disconnected to the actual art work, but rather directly connected to the reflection- and research processes before or after the actual art event. We will now, after the methodology section, follow six discourses and look into main disagreements and some significant arguments in the central discussions of ATR.

### Discourse analysis – a research journey

I started this research project by searching for articles and text books, but also post-graduate Applied Theatre programmes and research centres. I searched theory through Academic Search Premier, BISYS and ABI/Inform, and ATR-cohorts and environments through Google. My aim was to find interesting informants and texts in order to discover the main discourses in the field. I need to emphasise that I have not particularly searched for certain themes, keywords or subjects apart from ‘Applied Theatre’ in the searching process.

So this discourse journey across our field developed by following paths, structures and thoughts from one text to another, from one informant to another. I started out reading key books and key articles in the AT-field; Nicholson, 2005, Thompson, 2003, Taylor, 2003, Prendergast, Saxton, 2009, Prentki, Preston, 2009, Acroyd, 2000, Rasmussen, 2000 etc. I then followed the researchers’ tracks and checked the authors’ reference lists, and then went on reading new articles or new books. In the end after two years, no new discourses seemed to occur anymore.<sup>14</sup> The model below visualizes this research process:

<sup>14</sup> I decided to visit a selection of Universities in: London, Manchester, Brisbane and New York because of their well known research activity and/or Applied Theatre post-graduate programs. Booking field work is never easy,

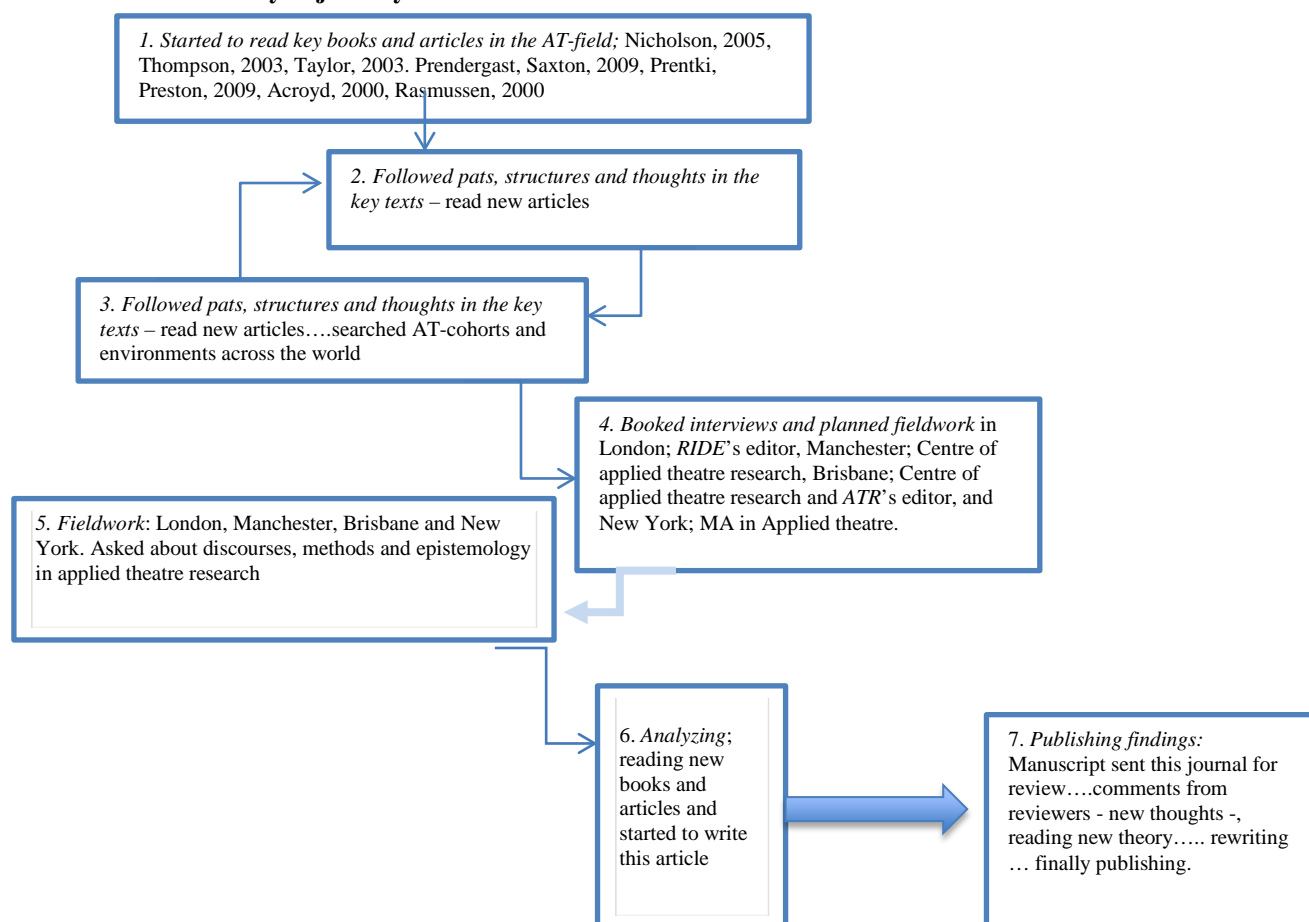
**Discourse analytic journey:**

I understand discourse within a Foucaultian perspective, and have used Michel Foucault's (1970) genealogical method to study ATR in order to analyse discourses that appear in texts and interviews within the field. Foucault's discourse analytic universe can be used to understand where and why meaning occurs (Winther, Jørgensen, and Phillips, 1999). The discourse term is used for arguments, meanings and discussions that all arise from one formation (Foucault 1969).

According to my chosen research platform, meaning is created in a socially constructed room in which coincidences and intentions live side by side. No man is an island - we all live in a community and are strongly affected by others' thoughts and behaviour (Andersen 1999). Some ways of thinking find its possibilities and opportunities in certain époques, periods and contexts (Foucault 1969). Hence, knowledge will be transformed in the melting pot where tradition, future, ideology and people all meet. This article is based on a research process influenced by this way of Foucaultian thinking.

In the process of writing this article, I have mixed various types of data in order to be able to discover aspects, structures and ideas in a genealogical way in today's Applied Theatre Research that is still constructed by components from the past (Andersen 1999; Beronius 1991; Hede 1992). Professor Emeritus in educational theatre, Anthony Jackson, emphasises that there may be lessons we can learn from the past in today's theatre field, and quotes Foucault by writing:

[1] /.../ genealogy looks for "emergence" rather than evolution /.../ for discontinuities, divergences and "marginal elements" in events and for the unstable assemblage of faults, fissures and heterogeneous layers/.../. (Jackson 2007, 10)

---

some colleges politely invite you and other colleges are difficult or impossible to get in contact with. I ended up interviewing 5 through SKYPE and e-mail and the rest of the informants face to face.

Foucault himself encourages the use of a combination of data production to reveal fractures and power struggles in otherwise apparently coherent and homogenised discursive systems (Foucault 1980). Thus I have tried to read all kinds of texts about applied theatre, such as; curriculum literature, research articles, web-pages, education programmes etc.

### **The field and purpose of Applied Theatre**

The recent academic interest in the field of Applied Theatre (AT) has emerged as a result of textbooks, articles, papers and reports that describe the philosophical basis, the aesthetics, the diverse challenges and the huge amount of working methods, as well as the implications of practice-based and art-based research methodology. Also international collaboration between researchers in associations as IDERI and IDEA and sharing ideas at conferences all over the world develops the field, according to Australian dr. Julie Dunn.<sup>15</sup> Researchers and practitioners also move between countries and share theoretical perspectives, teaching methods and research methodology. At Griffith University, Australian dr. Madonna Stinson told about her fruitful and professional challenging experience with moving between Applied Theatre environments in London and Singapore, Melbourne and Brisbane. Stinson, Dunn and several other informants emphasize an inspiring motivation for exchanging experience with researchers and practitioners from other countries and cultures. Doing fieldwork both in the US, Great Britain and Australia made me realize that most of the informants actually know each other, so it seems that applied theatre researchers and practitioners are quite tightly connected in professional or/and personal networks although the distance between them is far.

We can divide the field of AT into two practical arenas, namely that of educational contexts and community settings (Nicholson 2005, 2). Applied Theatre Practice (ATP) and Applied Theatre Research (ATR) are tightly connected and must therefore be analysed in relation to each other in a discourse study. According to Thompson, the academic discipline of AT has emerged from state-sponsored universities and outwards to practice, and not the other way around (2011 interview). There seems to be a ‘/.../consensus around key features of its practises, functions and political association’ (Neelands 2007, 306). In ATR, terms such as “social change” (Ackroyd 2000), “efficiency-entertainment” (Neeland 2007), “vulnerable points” and “marginal groups” (Nicholson 2005) are frequently used. Applied Theatre is often recognised as:

/.../ performance practices that have the potential to disrupt fixed polarities between art and instrumentalism, education and entertainment, popularism and elitism, process and product, activity and passivity, participation and spectatorship (Nicholson 2009, 80).

Applied Theatre is analysed by most theatre researchers as a type of theatre with quite different intentions, and predominantly with a focus on the participants (Nicholson 2005). According to the Australian researcher Phillip Taylor, the intentions can primarily be categorised into five different intentions: 1. doing activism/politics, 2. posing alternatives, 3. working with healing, 4. challenging contemporary discourses, and 5. presenting voices from the viewpoints of the silent and marginal (Taylor 2003).

In the field of ATR, the Canadian researchers, Monica Prendergast and Juliana Saxton (2009, 11), have contributed with nine characteristics of ATP in order to include every small and large ensemble in an overview of the field: *theatre in education, popular theatre, theatre of the oppressed, theatre in health education, theatre for development, prison theatre, museum theatre, reminiscence theatre and community-based theatre*.

In a research interview in September 2011 at Manchester University, British professor James Thompson emphasized that the term applied theatre was useful when it came into being in the 1990s, and that he especially appreciated the term *theatre* instead of *drama*, since it

<sup>15</sup> Interview, April 2012, Griffith University.



gave the field more status within the institutional power play that it certainly deserved and needed in order to obtain focus, power and funding. But the reason for Thompson to start using the term in the first place, and then writing a book about it in a 2003, was because it brought some quite different environments into the dialogue. He had previously also claimed that the term:

[2] /.../ supported a sharing of knowledge drawn from the fields of theatre in education, drama in education, and theatre for social change /.../ are brought into dialogue with each other/.../ the term that joins different categories of a socially engaged theatre without denying their separate histories or dictating what can be placed within their own boundaries (Thompson 2003, 14).

[3]

Even so, it is important to mention that some researchers in the field who actually conduct research on Applied Theatre almost refuse to use the term themselves.

Several of my informants (interview in 2011; Sally Bailey, Nils Braanaas and Stig Erikson) categorise their own work, in terms of artistic, pedagogic and scientific work, to be a part of AT as an umbrella term, though they somehow do not like the sound of it and therefore uses other terms about their work such as drama, drama therapy, theatre and performance, etc. One example could be the American disability theatre researcher, Sally Bailey from Kansas State University, who argues that:

I don't think it is a particularly useful term. It doesn't sound "fun" or "interesting" or "mainstream". It sounds like an "add on" or "extra" instead of being valid or important in its own right (Bailey interview, 2011).

Consequently, we see that the field of AT is a heterogeneous group of practitioners and researchers who do not always agree on the terms they use. Taylor (2003) describes Applied Theatre as a field mainly with a focus on raising questions and exploring opportunities, rather than on finding solutions, while Thompson (2003) says that AT is growing to be both a collective and a collecting theatre, one that is created by people who would not normally create theatre in such a context. It is a theatre that values debate and "/.../ that somehow balances the pragmatism involved in making itself relevant in difficult environments with the idealism of a belief in transformation" (Thompson 2003, 13). Taylor (2003) also believes that AT is a transformative practice, and views the field as empowering and with structural tools that can "/.../ facilitate wide-awakeners in participants" (Taylor 2003, 8) "/.../ for the purpose of transforming or changing human behaviour" (Taylor 2003, 2). Nicholson (2005) disagrees with Thompson and Taylor's use of the term "transformation". She finds it more suitable to use Schechner's term "transportation" in relation to Applied Theatre's dazzling imaginative contingency as an aesthetic communication media and a possible escape – as a fantasy away from everyday life (Nicholson 2005, 2011, 198). She writes that:

[4] Although I recognise the power of theatre-making to touch people's lives, I remain rather uneasy about using the term "transformation" to describe the process of change afforded by practising drama. This is partly because I feel uncomfortable about making such grand claims for the effects and effectiveness of my own work as a practitioner, but also because it raises bigger political questions/.../ is this something which is done *to* the participants, *with* them, or *by* them? (Nicholson 2005, 12).

[5]

Nicholson uses the term "transportation" instead of "transformation" in the sense of "going into another world and coming back with gifts" (Etchells 1999, 59 in Nicholson 2005, 13).

In Norwegian, the term "gift" means "poison", while it in English means "present", and it is precisely the dichotomy within the etymology of the term that Nicholson actually wants us to pick up when we read her book (Mauss 1924 in Nicholson 2005, 160). She believes that facilitators and researchers in Applied Theatre must acknowledge the uneasiness

at the core of the field, and she “/.../ indicate[s] the state of uncertainty associated with the gift, which might be experienced as either pleasure or displeasure” (Nicholson 2005, 160). In 2011, Nicholson elaborated on this issue by pointing to the messiness and unpredictability of theatre making, which brings to mind a quote by Walter Benjamin, “/.../ there is always an inescapability of imperfection inherent in all human endeavour” (Nicholson 2011, 15). Several other researchers share this argument with Nicholson, such as Jennifer Hartley: “Transformation is not necessarily what someone is seeking and it might not be productive in their lives” (Hartley 2012:147).

I map out this specific debate, which started in Applied Theatre’s early years, not only to demonstrate different viewpoints, but also because it gives us an example of *how discourses emerge*, how texts are written, how the language is used and how the researcher’s background, experience, cultural belonging and gender exert an influence on the discourse development itself.<sup>16</sup> Nicholson’s texts (2005, 2009, 2011) have a touch of “thoughtful polite scepticism” about them.<sup>17</sup> She indicates more than simply bombastically concluding about the possibilities of Educational- and Applied Theatre, or even the right to go into the life of the participants with the aim of “empowering” or “transforming”. In contrast, Taylor (2003) and Thompson (2003) in 2002-2003 seemed more certain and confident about Applied Theatre’s impact, efficiency and power on participants and societies, though Thompson changed his attitude after working on the “In Place of War” project at the Centre of Applied Theatre Research in Manchester (Thompson, 2009, Thompson, Hughes, and Balfour 2009). So perhaps more modestly and quietly, he argues in 2009 that the parameters for a “theatre for social change” are particularly porous (Thompson 2009, 4).

Hence, experience with real life on the edge, in crisis, with marginal voices and with human endeavour seem to perhaps change you as a practitioner, as a researcher - and as a whole human being - in all different kinds of ways (Jenny Hughes interview, 09.21.2011). So the positions of all authors seem to shift over time.

### Established definitions

First and foremost, there seems to be a collective global understanding that Applied Theatre is theatre outside conventional mainstream theatre houses that is applied in various (site-specific) arenas in different communities and everyday life settings worldwide (Prendergast and Saxton 2009; Prentki and Preston 2009; Taylor 2003; Thompson 2003; Ackroyd 2007; Nicholson 2005). Nevertheless, since the late 1990s two of the characteristics of Applied Theatre Research actually seem to be “diversity” and “tensions”.

Philip Taylor actually suggests that Applied Theatre (AT) has its foundation in the three P’s: Platform, People and Passion (Taylor 2003). Taylor also claims that AT is powered by a need for change, and that AT is able to open up a dialogue in everyday settings through the art of theatre (Taylor 2003, xx, xxix, xxviii). Throughout my discourse analysis, it seems that most Applied Theatre researchers, artists and facilitators agree on the following five baseline ‘concepts’ to define Applied Theatre as a whole: *Change, Dialogue, Platform, People and Passion* (Taylor, 2002). Yet, Norwegian researcher Bjørn Rasmussen argues that we in AT are looking at a wide range of practises and research projects which have a few things in common, apart from the fact that they are all applications *to* cultural contexts, rather than applications *from* theatre (Rasmussen 2000). Rasmussen claims that this way of understanding the term “applied” could result in that: “/.../ we would not see one or three

<sup>16</sup> This discussion is elaborated on together with students at the MA theatre course at Royal Holloway at the University of London on Sept. 26, 2011. Their opinion is a kind of “people knowledge” from a Foucaultian perspective.

<sup>17</sup> A term that the 13 students at the MA theatre course at Royal Holloway at the University of London used when they described the differences between Taylor, Thompson and Nicholson’s first applied theatre books on Sept. 26, 2011.

Methods, but hundreds of distinctive approaches emerging from a number of sets of complex contexts” (Rasmussen 2000, 2).

### **First discourse: Legitimizing discourse**

Anthony Jackson argues that the field of Applied Theatre has partially grown from what he defines as “educational theatre”, which has always felt the need to argue for its existence (Jackson 2007). Jackson exemplifies the legitimating rhetoric in both applied theatre and in educational theatre by referring to arguments written in the early 1920’s from British theatre director Harley Granville Barker:

[6] Barker’s idea [of an ‘exemplary theatre’, one which could and should educate – for clarity]/.../ that the theatre was a necessary part of a healthy, liberal society and needed to be recognized, and financially supported, by the state /.../ (Jackson 2007, 264).

[7] Applied Theatre Research seems to develop as a field were the researchers are all bitten by the same legitimating focus that the practitioners have been for a while according to Neelands 2007; Ehterton and Prentki 2006. Applied Theatre researchers often feel a need to legitimate their work by defending themselves against egalitarian attracts from the universities and the founders’ in the same way as the practitioners needs “/.../ some evaluation of the “impact” of the project” (Neelands 2007, 314). The legitimating rhetoric is occurring in a lot of texts (Mienczakowski 1997; Taylor 2003; Neelands 2009, O’Toole, 2009), as well in interviews, at conferences and of course in our own teaching at universities. Manchester University’s website informs us in what we can choose to analyse as a legitimating way that, “Applied Theatre projects have made positive contributions to the everyday life of individuals and communities in a variety of contexts”.<sup>18</sup> We can somehow smell the legitimating rhetoric in the background of this text, which we can also do on the City University of New York’s (CUNY) website when they explain the focus of their programmes and courses by writing that the Applied Theatre course is:

/.../ an ensemble-based program offering theoretical and practical instruction key elements of theatre and interactive drama strategies that can be ‘applied’ in a wide variety of settings to achieve defined educational and social outcomes.<sup>19</sup>

This brings us to the first discourse discovered in the study, namely “*the legitimating discourse*”. In connection to this legitimating discourse I have found it a bit harder in my study to actually discover researchers who use negative terms such as failure, weak or bad in their research on Applied Theatre projects, than those who use positive terms:

I noted the overwhelmingly positive descriptions of the work on the web and in conference papers, and I called for vigilance, since a powerful medium can be used for dubious as well as humanitarian ends (Ackroyd 2007, 1).

So it seems that positive words such as superlatives perhaps are more frequently used in ATR, as for example: “a gift” (Nicholson 2005, 160), “fruitful inquiry” (Taylor 2003: xxvii), “new possibilities for humankind” (Taylor 2003: xxx), and “/.../participants on the journey towards enlightenment” (Mienczakowski 1997: 170). Canadian researcher Kathleen Gallagher and her colleagues comment on this phenomenon, as they claim that it is often used with a very celebratory tone in this kind of research because AT fascinates, challenges and makes us enthusiastic (Gallagher et al. 2010). We can however discover a growing maturity in the field when we read some researchers who actually discuss the negative consequences for Applied Theatre, using negative terms such as bad, dangerous, damaging, oppressive, poison, disappointment and propaganda (Jackson 2007; Ackroyd 2007; Neelands 2007; Nicholson 2005; Sæbø 2009; Thompson 2006; Gallagher 2010, Jackson in Schonmann, 2011).

<sup>18</sup> <http://www.arts.manchester.ac.uk/catr/about/index.htm>, 12.07.2010

<sup>19</sup> <http://www.sps.cuny.edu/programs/spscourses/subjectdescription.aspx?sid=APTH>

## Second discourse: The effect discourse

Researchers dealing with questions on Applied Theatre's impact on society and participants tend to circle around "the function" of ATP, in addition to "the effect" and "the affect" that Applied Theatre can have on people through the terms "evaluate", "assess" and "measure". The basic lines in these effect rhetoric seem to be the questions of *why* measure Applied Theatre's processes/products, *for whom* are we measuring and *how* do we measure ATP at all (Dalrymple, 2006; Vuyk et al., 2010). We can split the effect discussions in two main arguments:

We find the "positive strand", which claims that effect measuring is important and worthwhile to pursue (represented here by Etherton and Prentki, 2006),<sup>20</sup> and we find the "negative strand", which claims that effect measuring can be a quite suspicious act that appears as porous (represented here by Thompson, 2009 and Jackson, 2001). Thompson argues from the "negative strand" that effect measuring is:

/.../ limited if it concentrates solely on effects' identifiable social outcomes, messages or impacts and forgets the radical potential of the freedom to enjoy beautiful radiant things (Thompson, 2009, 6).

This brings us to the study's second discourse, "the effect discourse", which is huge. It relates to issues such as ecology, philosophy, health, economics, politics and aesthetics.<sup>21</sup>

Thompson contributes with an important issue to the effect discourse that he defines as "the end of effect", and emphasises a distinctive focus on the performance affect (Thompson, 2009). While effect is defined as a result of a process or a particular influence, affect is often understood as an emotional description in terms of touching the feelings of someone, or to cause them to change.<sup>22</sup> Anthony Jackson suggested as early as in 2001, to difference between affect and effect, by focusing on what "/.../lie at the heart of any theatrical experience", by the use of "/.../ heartening measures of the "effectiveness"/.../ (Jackson, 2001: 169, 176). So Jackson and Thompson, among others, criticises researchers, facilitators, politicians, NGO's<sup>23</sup> and practitioners who fail to recognise affect in AT because:

[8] /.../bodily responses, sensations and aesthetic pleasure – much of the power of performance can be missed/.../ is limited if it concentrates solely on effects – identifiable social outcomes, messages or impacts (Thompson, 2009, 7- 6).

Etherton and Prentki (2006) wanted to debate effect discussions that in a themed issue of *RIDE*<sup>24</sup> I 2006. They then raised critical questions that got the reader to think more about the 'effect-study-need' in our field in order to explore both the intended and non-intended outcomes of AT. Etherton and Prentki summed up their themed edition of *RIDE* by sharing with us that it is:

[9] /.../ still not proven that applied theatre can today work towards those more substantial changes that many of its practitioners seek to make (Etherton and Prentki (2006, 154).

Some of course may argue against this viewpoint, thus there have been published both qualitative- and quantitative empiric studies that claim to prove the effect of Applied Theatre in schools, at workplaces and in the community as such (e.g. Sæbø 2009; Gjærum and Ramsdal 2008).

Through the "positive strand" in the effect discourse, Etherton and Prentki underscore the need for a more global collaboration among ATP workers through thoroughness of analysis, participatory methodologies and creativeness (Etherton and Prentki 2006). Essential

<sup>20</sup> I choose to pick just a few researchers in this discourse in order discuss them against each other, hence defining the discourse in a clearer manner.

<sup>21</sup> Ackroyd 2000; Jackson, 2001, McDonald 2005; Etherton and Prentki 2006; Dalrymple 2006; Balfour 2009; Fryer 2010; Jackson 2007; Vuyk et al. 2010; Nicholson 2011; Bottoms 2011; Mackey 2011; Thompson 2009.

<sup>22</sup> Concise Oxford English Dictionary, 2006, 21. [http://dictionary.cambridge.org/dictionary/british/affect\\_1?](http://dictionary.cambridge.org/dictionary/british/affect_1?)

<sup>23</sup> NGO: Non-Governmental Organization.

<sup>24</sup> *RIDE*: 2006/11:2.

issues in the positive strand of the effect discourse are the relationship between method, outcome and context, particularly in the meaning of including studies of ATP from among the poorest or most oppressed people, and from among materially comfortable people (Etherton and Prentki 2006, 139). The British researcher Judith Ackroyd also admits that “/.../ there is a crying need for evaluation of applied theatre” (Ackroyd, 2000, 2). Etherton and Prentki claim that there is a difference, between “‘impact measuring’ the Applied Theatre-projects to fit the requirements of the funders and the “‘project evaluation’, which is made for the practitioners themselves and understood as: “/.../proving what was claimed to be done was actually done’ (Etherton and Prentki 2006, 154). Several researchers point out the necessity for this kind of evaluation in for example classroom drama, the theatre for development or in community theatre that does not deal with the classical notion of effect (Winston 1998; Fryer 2010; Jeffers interview 2011; Chinyowa 2011). The South African researcher Kennedy Chinyowa reports from a recent Applied Theatre study that the few available monitoring and evaluation reports, “/.../display a clear lack of focus on the process of applied drama and theatre as an embodied performance practice /.../” (Chinyowa 2011, 352). He suggests a new form of evaluation that manages to combine different types of evaluation methods in order to pick up on nuances, cultural differences and the embodied learning process that include the notion of affect (Chinyowa, 2011, 352).

In my opinion, Chinyowa’s input to the effect discourse merges the notions of “effect’ and “affect’, albeit with a strong focus on the participants’ own consideration for how Applied Theatre acts have changed their feelings or minds, briefly touched their imagination or given them some kind of new knowledge or aesthetic experiences in any way (Edminstone 2000, 68). British researcher Nic Fryer (2010) suggests shifting the focus in evaluation and assessment from critical and reproductive towards: “/.../seeing it as a quest for new possibilities, as creative engagement with moving both artistic and social practice forward” (Fryer 2010, 560).

As I have analysed the “‘positive- and the negative strands’ of the effect discourse, researchers on both sides actually seem to agree about a concern for the survival of Applied Theatre due to funding and integrity. Balfour actually links the two strands to some extent when he concludes that it is difficult to measure, evaluate and assess AT, thus “/.../ what applied does is not always linear, rational and conclusive in its outcomes, but often more messy, incomplete, complex and tentative” (Balfour 2009, 357). So, the dilemma in the effect discourse can be summed up through Balfour when he emphasises that, “‘Practice does need to be funded, but not at any price’ (Balfour, 2009, 357).

### **Third discourse: The ethics discourse**

This lead us to the third discourse in the study, “‘the ethics discourse’, which contains difficult dilemmas, simple questions and more theoretical and philosophical views on Applied Theatre. At the core of the ethics discourse, we find theoretical analysis of the AT workers’ “‘role’. There seems to be an agreement in the ethics discourse that the AT workers “/.../suddenly and without prior indication, /.../ are in the middle of an ethical minefield” (Cohen and Manion 1994, 348 in Thompson 2003, 173). No one claims to have a solution for the moral and ethical questions in AT, although James Thompson (2003) manages to build an ethical discourse universe that several other researchers seem to pick up on and further develop (e.g. Nicholson 2005; Stuart-Fischer 2005; Dalrymple 2006; Neelands 2007).

The so-called, “‘approved and powered voices” in the ATR environment, including those in student handbooks, journals and research conferences, speak with almost the same voice in the ethics discourse the way that I perceive them. The ethics discourse seems to grow its path through numerous *dichotomies*, for example:

- Between “‘necessary clarity” and “‘creative confusion”
- Between “‘integrity of the practitioner” and “‘demands from the economic funders”

- Between “equality” and the “difference’ (Thompson 2003; Etherton and Prentki 2006; Neelands 2007; Mullen 2011).

British Amanda Stuart Fisher (2005) emphasize the agreement within the ATR-field about that ethical values are relative and that site-specific performances and processes are ethically supposed to develop in a dialogic relationship between the facilitates and the other participants, though this is not easy. Stuart-Fisher’s analysis of the AT workers’ ethics practice, as “/.../responsive and responsible to each of the different contexts” that they visit (Stuart-Fisher 2005, 247). This brings us further into the discursive universe to another discourse which I have chosen to call “the outsider-visitor discourse”, which is this study’s next discourse.

#### **Fourth discourse: The outsider- visitor discourse**

The role of the Applied Theatre worker as an actor, a facilitator, a director, a pedagogue or a therapist has been heavily discussed throughout the history of Applied Theatre field-research (Jackson 2007; Thompson and Schechner 2004). Apart from these terms, the role of the “visitor” seems prominent in a critical discourse, which I name “the outsider-visitor discourse”.<sup>25</sup> In 2003, Thompson phrased the main dilemma in “the outsider-visitor discourse” in this way:

[10] We will always be external to these changing and historically specific debates. Applied theatre comes to psychology, development and prison education /.../ but cannot speak for or speak from those fields. We are only ever visitors within the disciplines into which we apply our theatre (Thompson, 2003, 20).

So the first strand in this discourse is the one which claim that AT-workers always will stay in the role as the gest or visitor within a field.

Neelands (2007) argues against Thompson’s (2003) analysis of the visitor role when he claims that there is actually *no outside* because we in the globalised community are both informed and can possibly travel anywhere if we actually want to become involved in a conflict, a theme or a subject. So Neelands represent the other strand in this discourse. According to Neelands (2007), there is no outside because everyone lives within a social dialogue:

The AT practitioner rightfully and unavoidably enters into a social dialogue with a group’s constructed account of itself, and through this process both the “visitor’ and the group begin to shift and develop their intersubjective understandings (Neelands 2007, 309-310).

Neelands’ thoughts from 2007 sound theoretical, though perhaps a bit idealistic, when compared with Kennedy Chinyowa, who articulates quite clearly that the outsider discourse is very much alive in Africa, even in 2011: “Instead of acting as change agents /.../ [they] have failed to liberate themselves from their class conditioning as the thinkers and experts (Chinyowa 2011, 353). So even if Neelands (2007) may be right about his assumption that theoretically there “is no outside’, the outsider visitor discourse is still very much present and relevant in today’s Applied Theatre in Africa.

#### **Fifth discourse: The global economy discourse**

The field of Applied Theatre and Research may be regarded as global, if we see globalisation as the “/.../ intensification of worldwide social relations in such a way that local happenings are shaped by events occurring many miles away and vice versa” (Rebellato 2009, 4). There exist enormously different practices of Applied Theatre all over the world, as well as a wide range of research within the field that is globally connected through different

---

<sup>25</sup> Many researchers write within this outsider-visitor discourse (e.g. Stuart-Fisher, Nicholson, Taylor), although I just chose two representatives for the two strands in the discourse in this section in order to keep the discussion tighter.

communication channels.<sup>26</sup> It seems as if many researchers and practitioners actually travel all over the world in an attempt to try and save it.<sup>27</sup>

Several Applied Theatre researchers analyse the relation between the international funding agencies, the researchers and the applied theatre facilitators, by linking “international politics”, “the social change agenda” and the “aesthetic demands”, which can be analysed as a growing new discourse (Dalrymple 2006; Neelands 2007; Ackroyd 2007, Chinyowa 2006; Thompson, Hughes, and Balfour 2009; Prendergast and Saxton 2009; Chinyowa 2011).

Among other official organisations nowadays, the Development Education Association (DEA) in the UK actually underlines the important role of the arts such as Applied Theatre, “/.../as means of educating young people in the processes of “building a better tomorrow” (Etherton and Prentki 2006, 143). Nonetheless, these art-based targets in the UK and other European countries are often ignored by politicians because they need to play a political power game through what they call an “ethical foreign policy” in order to make decisions which would not:

[11] /.../ contradict the wishes of its most powerful ally, the USA /.../ This context is summed up in the term globalisation, meaning here macroeconomics /.../, global communications /.../ and inequitable power relations (Etherton and Prentki 2006, 143).

This dilemma is a complicated one and the unbalanced relationship within international politics strongly influences some Applied Theatre workers, whereas others are structured more locally and are less dependent on such issues as conjunctures, conflicts and wars (Reeves 2002). A Dutch PhD student at the University of Manchester, Kirsten Broekman, discussed problems with good interventions in relation to the global economics of Applied Theatre at “Theatre and Performance Research Association” (TaPRA) in September 2011 in the UK. Broekman’s new research emphasised the problems that occur with different sets of values attached to the competing aesthetic criteria of the practitioners, the non-governmental organizations (NGO), the spectators and the local government. Broekman, in addition to several other researchers such as Baz Kershaw, Helen Nicholson and Sally Mackey, further discussed on TaPRA, 2011, the dilemmas and conflict between power, money and art. Also Molly Mullen, a PhD student from New Zealand, presented her ATR-research at TaPRA which seeks to understand the different economies of applied theatre.

Mullen claims that theatre practices are usually subsidized through public grants, or respond to local, national and/or international policy to attract other sources of funding. Previous studies have suggested that economic factors and conditions have significant implications for the pedagogies, aesthetics, politics and ethics of applied theatre practices. It is suggested that their financial dependency make them, and the values that inform them, vulnerable to the agendas of funders and other stakeholders.<sup>28</sup>

These discussions on TaPRA and the two new PhD-research projects tells us that there is a growing interest for the economy of applied theatre, thus it brings us into to the study’s fifth discourse, which can be analysed as “the global economy discourse”. This discourse is developing as conglomerate of critical discussions about the role of the international funding agencies and the cooperation between facilitators and the local community in projects which aim for social change through art (Dalrymple 2006; Neelands 2007; Ackroyd 2007, Chinyowa 2006; Thompson, Hughes, and Balfour 2009; Prendergast and Saxton 2009; Chinyowa 2011). The main themes in this research are: “international politics”, “the social change agenda” and the “aesthetic demands”.

<sup>26</sup> Such as: conferences, study trips, the web, TV, newspapers, blogs, books, articles, pictures, DVDs, etc.

<sup>27</sup> According to an interview with Helen Nicholson in 2011.

<sup>28</sup> <http://auckland.academia.edu/MollyMullen/Talks>, downloaded 07.12.12. This abstract is similar to the abstract at Tapra, 2011, which is unfortunately not online.

### **Fifth discourse: The aesthetic discourse**

In November 2010, RIDE published a themed edition on “aesthetics”. The theme editors, Brad Haseman and Joe Winston, argued that the field of AT has, not surprisingly, concerned itself more “/.../readily with issues of social utility” and less with the notion of aesthetics (Haseman and Winston 2010, 465). The editors and researchers in the themed issue felt that we needed a “/.../ reminder of the importance of aesthetics in the field of applied theatre” (Haseman and Winston 2010, 474). Anthony Jackson is also highly concerned with the lack of focus on aesthetics, and wrote in 2007 that we have “/.../to embrace the artistic core of what we do” (Jackson 2007, 272). He repeats his argument in 2011, in an interview by saying that without aesthetics Applied Theatre is nothing. In 2009 Prendergast and Saxton also questioned the problems with “/.../poor production value” and “/.../ the lack of aesthetic sensibility” in Applied Theatre (Prendergast, Saxton 2009:187). They discussed the importance of epistemological focusing on the aesthetic dimensions within Applied Theatre in order to develop a theatre that motivates the spectators: “/.../ to imagine things as if they could be otherwise” and use their feelings as the “glue” that makes things stick in the memory (Greene 1988:3 in Prendergast, Saxton 2009:188). Some researchers though are sceptical about the co-called “aesthetic turn”, according to Haseman and Winston (2010), because these researchers tend to claim that the aesthetic focus can represent a kind of a disrespect of the drama performed in schools.

We can clearly see that there is developing an aesthetic focus in Applied Theatre Research, and this leads us to the study’s sixth discourse, “the aesthetic discourse”, which seems to be a growing one (Prendergast, Saxton, 2009, Thompson 2006; Bundy 2010; Winston 2006; Jackson 2007; Rasmussen 2008; Boal, 2008, Jennings 2010; Rea 2008; Gallagher et al. 2010; Nicholson 2011). The discourse mainly contains discussions between the aesthetic focus and the more political or educational viewpoints, as well as more philosophical thoughts and debates around theatre and performance.<sup>29</sup>

### **Summing up: Swampy lowland and hard highland**

Before I started on this research journey I wanted to perhaps manage to clarify things and offer new ways of thinking about applied theatre as an established field. This discourse study shows us though, that Applied Theatre Research is a discursive global field build up by six main discourses. The following six discourses can be understood as a constructed overview of the Applied Theatre Research from the late 90s until today: The legitimization discourse, the ethics discourse, the effect discourse, the outsider-visitor discourse, the global economy discourse and the aesthetic discourse.

Lynn Dalrymple (2006) claims that the goal of Applied Theatre and Applied Theatre Research is to “/.../ provide a unique experience or another way of knowing and understanding the world that cannot be measured using tools drawn from the social or physical sciences” (Dalrymple 2006, 201). According to both Dalrymple the complex field of Applied Theatre as a special form of knowledge structure, can never fully be described by verbal language (Dalrymple 2006, McNiff 2009).

Therefore through this article I can only grasp the surface of our discursive field by showing pieces of central discussions, and reveal fractures and a bit of some ‘power struggles’ in a heterogeneous discursive system (Foucault 1980). James Thompson (2003) argues for a connection between knowledge types as a basis for ATR when he claims that “/.../ a shift away from direct theorising must be attempted” (Thompson 2003, 176). He shares this view on knowledge with postmodernist ethnographers (Taylor 1986; Saldaña 1998), all of which support ethnographic research seen as: “evocation”, “a performative break” and

<sup>29</sup> RIDE changed its name from *Research in Drama Education* (founded in 1996) in 2009 to *Research in Drama Education: The Journal of Applied Theatre and Performance*; from a discourse analytic perspective, this act can be understood as part of the “aesthetic turn”.



“ethics”, rather than research *only* as “explanation” (Thompson 2003, 176). Jennifer Harley (2012) also points out the need of a connection between knowledge types as a basis for At and ATR, when she writes in her brand new textbook, *Applied theatre in action: a journey*, that  
 /.../ we need to see the connecting paths and move between them constantly, finding a way around the obstacles/.../ It is crucial to remember that everything connects” (Harley, 2012:148).

The researchers Hughes, Kidd and McNamara emphasise Applied Theatre and Applied Theatre Research *inter-connects* and that we in our field balance between the “/.../ swampy lowland where situations are confusing ‘messes’ incapable of technical solution” and the “/.../ high, hard ground where practitioners can make effective use of research-based theory and technique” (Hughes, Kidd, and McNamara 2011, 186). So perhaps both practitioners and researchers in the heterogeneous discursive field of Applied Theatre, all try to balance on the wire between “the swampy lowland” and the “high, hard ground” as a tightrope walker without falling down? Applied Theatre contributes to our lives with a circus balance show that is aesthetically risky and which reminds us of the shadows when the lights go off and the makeup fades.

### References:

- Ackroyd, J. 2000. Applied theatre: Problems and possibilities, *Applied Theatre Researcher*, no. 1, 2000, [http://www.griffith.edu.au/data/assets/pdf\\_file/0004/81796/Ackroyd.pdf](http://www.griffith.edu.au/data/assets/pdf_file/0004/81796/Ackroyd.pdf), downloaded 10.31.2011.
- Ackroyd, J. 2007. Applied theatre: An Exclusionary Discourse? *Applied Theatre Researcher*, [http://www.griffith.edu.au/data/assets/pdf\\_file/0005/52889/01-ackroyd-final.pdf](http://www.griffith.edu.au/data/assets/pdf_file/0005/52889/01-ackroyd-final.pdf), downloaded 10.31.2011.
- Andersen, N.Å. 1999. *Diskursive analysestrategier*, København: Fredriksberg boktrykkeri.
- Aristotle. 1989. *Poetikken: om dikterkunsten*, Oslo: Dreyers bibliotek.
- Aristotle. 350 BC. *Nicomachean Ethics*, [http://www.constitution.org/ari/ethic\\_00.htm](http://www.constitution.org/ari/ethic_00.htm), downloaded 10.12.2011.
- Bailey, S. 2010. *Barrier-free theatre: Including everyone in Theatre Arts – in Schools, Recreation, and Arts Programs – Regardless of .Dis. Ability*, Enumclaw: Idyll Arbor.
- Balfour, M. 2009. The politics of intentions: looking for a theatre of little changes, *Research in Drama Education: The Journal of Applied Theatre and Performance* 14:3, 347-359..
- Boal, A. 2008. *The aesthetics of the oppressed*, London: Routledge.
- Berinius, Mats .1991. *Genealogi och Sociologi*, Stockholm: Symposion Bibliotek.
- Bottoms, S. 2011. Failing to Perform: Heritage Sites as Eco-Systems, *TaPRA Abstracts & Biographies*, Annual Conference, September 7-9, 2011.
- Chinyowa, K. C. 2011. Revisiting monitoring and evaluation strategies for applied drama and theatre practice in African contexts, *Research in Drama Education: The Journal of Applied Theatre and Performance* 16:3, 337- 356.
- Chinyowa, K. C. 2006. Evaluating the Efficacy of Community Theatre, Intervention in/as Performance: A South African case study, *Applied Theatre Researcher*, [http://www.griffith.edu.au/data/assets/pdf\\_file/0009/114957/06-Chinyowa.pdf](http://www.griffith.edu.au/data/assets/pdf_file/0009/114957/06-Chinyowa.pdf), downloaded 10.31.2011.
- Dalrymple, L. 2006. Has it made a difference? Understanding and measuring the impact of applied theatre with young people in the South African context, *Research in Drama Education: The Journal of Applied Theatre and Performance* 11:2, 201-218.
- Edminston, B. 2000. Drama as Ethical education, *Research in Drama Education: The Journal of Applied Theatre and Performance*, 5:1, 63-84.
- Etherton, M., Prentki, T. 2006. Drama for change? Prove it! Impact assessment in applied theatre, *Research in Drama Education: The Journal of Applied Theatre and Performance* 11:2, 139-155.

- Foucault, M. 1969. *The Archaeology of Knowledge*, New York: Routledge.
- Foucault, M. 1970. *Diskursenes orden*, Oslo: Spartacus Forlag.
- Foucault, M. 1980. *Power/knowledge: Selected interviews and Other Writings 1972- 1977*. Hemel Hempstead: Harvester Wheatsheaf.
- Gallagher, K., Freeman, B., Wessels, A. 2010. It could have been so much better: The aesthetic and social work of theatre, *Research in Drama Education: The Journal of Applied Theatre and Performance* 15:1, 5-27.
- Gjærum, R.G., Ramsdal, G. 2008. Forum theatre and Self-Esteem - Forum theatre's strong impact on communicative coping in conflict, *Applied Theatre Researcher*, 3-18.
- Harley, J. S. 2012. *Applied theatre in action: a journey*, London: Trentham Books Limited.
- Haseman, B., Winston, J. 2010. 'Why be interested?' Aesthetics, applied theatre and drama education, *Research in Drama Education: The Journal of Applied Theatre and Performance* 15:4, 465-475. 15:1, 39-58.
- Hughes, J., Kidd, J., McNamara, C. 2011. The Usefulness of Mess: Artistry, Improvisation and Decomposition in the Practice of Research in Applied Theatre. In: Baz Kershaw, Helen Nicholson (eds.), 2011. *Research Methods in Theatre and Performance*, Edinburgh: Edinburgh University Press, 186-210.
- Jackson, A. 2001. You had to watch it to realise what it were like...: Researching Audiences for Educational Theatre'. In: Rasmussen, B, Østern, A.L. 2001. *Playing Betwixt and Between: The IDEA 2001 Dialogues*, Bergen: IDEA Publications IDEA World Congress.
- Jackson, A. 2007. *Theatre, education & the making of meanings: art or instrument?* MUP.
- Jennings, M. 2010. Aesthetics and efficacy in community theatre in contemporary Northern Ireland, *Research in Drama Education: The Journal of Applied Theatre and Performance* 15:1, 111-117.
- McNiff, S. 2009. *Art-Based Research*, London: Jessica Kinsley Publishers.
- McDonald, B. 2005. Towards a theatre of little changes – a dialogue about dialogue, *Research in Drama Education: The Journal of Applied Theatre and Performance* 10:1, 67-74.
- Mieczakowski, J. 1997. Theatre of Change, *Research in Drama Education, The Journal of Applied Theatre and Performance* 2:2, 159-172.
- Mullen, M. 2011. Uncomfortable bed follows: Applied theatre and its relationship with economy, *TaPRA Abstracts & Biographies*, Annual Conference, September 7-9, 2011.
- Neelands, J. 2004. Miracles are happening: Beyond the rhetoric of transformation in the Western traditions of drama education, *Research in Drama Education: The Journal of Applied Theatre and Performance* 9:1, 47-56.
- Neelands, J. 2007. Taming the political: The struggle over recognition in the politics of applied theatre, *Research in Drama Education: The Journal of Applied Theatre and Performance* 12:3, 305-317.
- Neelands, J. 2009. Acting together: Ensemble as a democratic process in art and life, *Research in Drama Education: The Journal of Applied Theatre and Performance* 14:2, 173-189.
- Nicholson, H. 2005. *Applied drama: The gift of theatre*, London: Palgrave.
- Nicholson, H. 2009. *Theatre and education*, London: Palgrave.
- Nicholson, H. 2011. Attending to Sites of Learning: London and Pedagogies of Scale, *TaPRA Abstracts & Biographies*, Annual Conference, September 7-9, 2011.
- O'Toole, J. 2009. Writing everyday theatre: Applied theatre, or just TIE rides again?, *Research in Drama Education: The Journal of Applied Theatre and Performance* 14:4, 479-501.
- Prendergast, M., Saxton, J. 2009. *Applied Theatre: Globalized case studies and challenges for practice*, Bristol: Intellect.
- Prentki, T., Preston, S. (eds.) 2009. *The Applied Theatre Reader*, New York: Routledge.

- Rasmussen, B. 2000. Applied theatre and the power play: An international viewpoint, *Applied Theatre Researcher*, [http://www.griffith.edu.au/\\_data/assets/pdf\\_file/0006/81798/Rasmussen.pdf](http://www.griffith.edu.au/_data/assets/pdf_file/0006/81798/Rasmussen.pdf), downloaded 10.31.2011.
- Rasmussen, B. 2008. Beyond imitation and representation: Extended comprehension of memesis in drama education, *Research in Drama Education: The Journal of Applied Theatre and Performance* 13:3, 307-319.
- Rasmussen, B. 2010. The 'good enough drama'; Reinterpretation constructivist aesthetics and epistemology in drama education, *Research in Drama Education: The Journal of Applied Theatre and Performance*.
- Rea, D. 2008. Refugee performance: Aesthetic representation and accountability in playback theatre, *Research in Drama Education: The Journal of Applied Theatre and Performance* 13:2, 211-215.
- Rebellato, D. 2009. *Theatre & Globalisation*, Hampshire: Palgrave Macmillan.
- Reeves, H. 2002. *Measuring the social and economic impact of the arts*, London: Arts Council of England.
- Saldaña, J. 1998. Ethical issues in Ethnographic Performance Text: "The Dramatic Impact" of "Juicy Stuff", *Research in Drama Education* 3: 2, 181-196.
- Schonmann, S. (2011). Key concepts in theatre/drama education, Rotterdam: Sense Publishers.
- Stuart-Fisher, A. 2005. Developing an ethics of practice in applied theatre: Badio and fidelity to the truth of the event, *Research in Drama Education: The Journal of Applied Theatre and Performance* 10:2, 257-252.
- Sæbø, A. 2009. Challenges and possibilities in Norwegian classroom drama practice, *Research in Drama Education: The Journal of Applied Theatre and Performance* 14: 2. 279 – 294.
- Taylor, P. 2003. *Applied Theatre: Creating Transformative Encounters in the Community*, Portsmouth: Heinemann.
- Taylor, S. 1986. Post-Modern Ethnography: From Document of the Occult to Occult Document, J. Clifford and G. E. Marcus (eds.), *Writing Culture: The Poetics and Politics of Ethnography*, London, University of California Press.
- Thompson, J. 2003. *Applied Theatre: Bewilderment and Beyond*, Oxford: Peter Lang.
- Thompson, J., Schechner, R. 2004. Why Social Theatre ? *TDR* 48/3, 11-16.
- Thompson, J. 2006. Performance of pain, performance of beauty, *Research in Drama Education: The Journal of Applied Theatre and Performance* 11:1, 47-57.
- Thompson, J. 2009. Performance affects: Applied theatre and the end of effect, London: Palgrave.
- Thompson, J., Hughes, J., Balfour, M. 2009. *Performance in place of war*, London: Seagull.
- Vuyk, K., Poelman, L., Cerovecki, I., van Ervern, E. 2010. To be Dutch or to be Turkish, that is the question, or, how to measure the reception of community-based plays about living between cultures, *Research in Drama Education: The Journal of Applied Theatre and Performance* 15:3, 339-359.
- Winston, J. 1998. *Drama, Narrative and Moral Education: Exploring traditional tales in the primary years*, London: Falmer.
- Winston, J. 2006. By way of an introduction, some initial reflections on beauty, *Research in Drama Education: The Journal of Applied Theatre and Performance* 11:1, 43-45.

# RICHARD WAGNER'S OPERAS IN 21<sup>ST</sup> CENTURY BALTICS: THE SAME WAGNER OR ANOTHER?

*MA Arts Lauma Mellena-Bartkevica*  
University of Latvia, Latvia

---

## Abstract

Celebrating the anniversary 200 of Richard Wagner, also the opera theaters of the Baltic States have paid the tribute to the great German composer and thinker by staging several operas, and even a full „Ring” cycle at the Latvian National Opera. Apart from the anniversary, the question of how the ideas of Wagner are interpreted nowadays arises, starting from his concept of the total work of art (Gesamtkunstwerk) and ending up with the stage director as the new author, who recreates the story in a postmodern way, adding new contexts and interpretations to the initial ideas. The paper will analyze particularly the “Ring” cycle in Riga performed fully after a 100 years break, questioning the existing stereotypes related to Wagner’s music and personality that impede to be open for new interpretations and the complex semantic density created by the stage directors. The main aspects will concern the general problematics of the contemporary productions of so called “classical” operas in terms of representation and reception, the postmodern approach to the opera direction, mostly represented by combination of the mythical and archetypal structures of Wagner’s original works with the contexts and references to the modernity and the history of the 20<sup>th</sup> century, thus re-creating the Wagner’s story in new dimensions to be perceived by the modern opera goer able to uncover different layers of the meanings depending on his knowledge and experience. Also the question of why Wagner is/might be topical nowadays will be discussed.

---

**Keywords:** Wagner, opera, postmodernism, contemporary productions, contexts, interpretation

## Introduction:

In 2013 the bicentenary of the great German composer Richard Wagner is celebrated throughout the world. This anniversary is marked by numerous productions of Wagner’s famous operas, such as “Tannhäuser”, “Lohengrin”, “Parsifal” and, of course, the “Ring” cycle consisting of “Das Rheingold”, “Die Walküre”, “Siegfried” and “Götterdämmerung” and considered to be the *opus magnum* of his life completed during a quarter of century. 21<sup>st</sup> century brings postmodernism on the scene of opera theatres more than before, challenging both the critics and the audiences with new stage directors’ interpretations full of contextual and symbolic references to the 20<sup>th</sup> century socio-historical past uncovering the sources of today’s cultural relativism, questioning the values and reflecting the interplay between the art and the society through opera audiences. Apart from being a composer and author of all librettos of his own operas, Wagner was a progenitive thinker, who widely expressed his theoretical views regarding opera and art in general, which cannot be overlooked. The complexity of the hermeneutics of the contemporary productions of Wagner’s operas is rooted in the multi-layered structure that comprises all symbolic density included in the music and libretto by Wagner himself and different contexts basically chosen by the stage directors and represented mainly in visual symbols making a “collage” of the original material and director’s interpretation. We will see it further in the examples of “Ring” cycle productions by

the Latvian National Opera. But, first of all, let us make a historical excursus about Wagner's relation to the Baltic region.

## I.

In the light of 2013 – the bicentenary year of Richard Wagner and 2014 – the year of Riga in the status of European Cultural Capital, Riga has taken the opportunity to emphasize the right to the status of a “Wagnerian city” as Richard Wagner spent two years of his early career (1837.-1839.) in Riga, conducting in Riga German theatre of the time. Among his works from Riga period, the song “Der Tannenbaum” and the libretto of the opera “Rienzi” on Roman tribune should be mentioned. Despite one might say that young Wagner was forced to come to Riga since he was run out of money in Königsberg, which is true, yet, considering the mobility of the time his stop in Riga for few years should not be underestimated at least in terms of contribution to the local musical life and the consequences in terms of development of so called Wagnerism around the Baltic sea in the 19<sup>th</sup> century and the attitude towards Wagner's musical heritage throughout the 20<sup>th</sup> century, when the territory of the Baltic States was a battlefield between Russian and German troops in two world wars, and 50 years of Soviet era. The topic of Wagnerism in Baltic States and Scandinavia is widely discussed in the recent and exhaustive research made by Finnish scholar Hannu Salmi (Salmi, 2005) and previously partially covered by Rosamund Bartlett's writings on Wagner's impact on Russian literature and culture, especially Russian symbolism, as well as on changing ideological perspectives in Russia since the end of the 19<sup>th</sup> century up to the 90ies of the 20<sup>th</sup> century (Bartlett, 1995). However, since the beginning of the 21<sup>st</sup> century a new wave of Wagnerism seems to be forming provoked by the bicentenary of Wagner and also by the accessibility to newest opera productions and Wagner's operas among them via periodically available HD transmissions from renown theatres, such as Metropolitan opera New York, Royal opera Covent Garden or Teatro alla Scala, as well as via satellite TV (i.e. *Mezzo*) and DVD recordings.

Statistically, since the millennium the opera theatres of the Baltic States have staged around 15 productions of Wagner's music dramas, including few concert performances and ballet projects based on Wagner's music.

Latvian National Opera	Lithuanian National Opera	Estonian National Opera
<p>“Der Fliegende Holländer” (2003/Andrejs Zagars, LV) Ring cycle: “Das Rheingold” 2006, revival 2013/Stefan Herheim, DE) “Die Walküre” (2007/Viesturs Kairiņš, LV) revival scheduled for 2015 “Siegfried”, (2008/Viesturs Kairiņš, LV) revival scheduled for 2016. “Gotterdammerung” (2011/Viesturs Kairiņš, LV) Full cycle performed in Riga Opera Festival in June, 2013.</p> <p>Other Wagner operas scheduled:</p> <p>“Rienzi” scheduled for 2014/Kirsten Dalholm, DN) “Parsifal” scheduled for (2015/Andrejs Žagars, LV)</p>	<p>“Der Fliegende Holländer” (2004 /Francesca Zambello, USA) “Parsifal” (concert performance) – 2004/cond. Gintaras Rinkievičius “Die Walkure” (2007/Eimuntas Nekrosius, LT) “Parsifal” – guest performance of the Mariinsky Theatre (2009/ Valery Gergiev, director Tony Palmer, UK) “Tristan and Isolde”, a ballet to the music by Richard Wagner 2012/ chor. Krzysztof Pastor, PL “Lohengrin”, (2013/Andrejs Zagars, LV) <i>A co-production between the LNOBT and the Slovak National Theatre</i></p>	<p>“Tannhäuser“, concert performance in Tallin, Pärnu and Tartu (2003.) „Tristan und Isolde“ (2008/Neeme Kuningas, EE) „Parsifal“ (2011/Nicola Raab, DE) „Tannhuser“ (2013/ Daniel Slater, UK)</p>

Considering the resources required for Wagner's music dramas, starting from orchestra musicians, conductors, and singers ready for Wagner repertoire and ending up with the stage directors brave enough to take the challenge, main opera theatres of the Baltic States in the latest decade have proved to be able to handle Wagner. If we see the names of stage directors involved, the balance between local and invited stage directors is proportional: we have 4 Baltic stage directors and 4 invited directors. Riga seems to be the leader in number of Wagner productions and deserves an additional bonus for full "Ring" cycle staged after 100 years, thus justifying its status as "Wagner's city" among Baltic capitals. By the way, after the Second World War, Riga was the first city in USSR where the operas of "ideologically controversial" Richard Wagner were allowed.

All Baltic productions have been staged more or less within a framework of postmodern aesthetics, some of them by the approach of re-creating the story in another chronotope and modifying the plot (i.e. "Das Rheingold" in Riga, "Lohengrin" in Vilnius", "Tannhäuser" in Tallin) that is typical for the *Regietheater* or director's theatre, one of the most widespread postmodern stage direction practices nowadays, particularly in Europe. *Regietheater* is one of the currently flourishing and dominating flows in contemporary opera productions all over the world. Accordingly, the question, whether this trend is sustainable phenomenon or just a temporary fashion, should be put. Has the so called "classical opera" come to the end? As for Wagner's operas, it can be argued, that the *Regietheater* has begun in the middle of the 20<sup>th</sup> century with experimental minimalist and very symbolic productions by the famous composer's grandson Wieland Wagner, who rooted his concepts in the theories by Adolph Appia and continued by the "French revolution in Bayreuth", namely, the legendary centennial Bayreuth Ring cycle staged by Patrice Chéreau and conducted by Pierre Boulez in 1976. Therefore the *Regietheater* is not necessarily a swearword when talking about opera as far as the idea behind it is to tell an old story in a new way, applying supposedly associative contexts and symbols to bring closer the plot and the audience. No doubt, the stage director in a way has become a new author of the opera, but from the ethical point of view his right to distort the original whole of text and music should be questioned. The big question is what makes a new interpretation different from misinterpretation, especially without set ideological frame? For instance, Rosamund Bartlett who had researched widely the performance and reception history of Wagner's operas in Russia has come to a paradoxical conclusion:

*"[...] although Russia's fascination with Wagner had persisted far longer than that of other European countries, it was now something which definitely belonged to the past. It was extraordinary enough that a nineteenth-century composer could exert a hold over Russian creativity as late as 1940, but it was only natural that Wagner's influence should diminish once it became clear that the utopian dreams of an ideal art for the masses which would transform the new socialist society would never become a reality. It is no coincidence that Russian Wagnerism died with the end of Stalinism."* (Bartlett, 1995)

Wagner's music dramas are challenging due to their symbolic complexity of the plot and it's relation to the score, due to the existing historical traditions of production and due to different well-settled stereotypes and prejudices about Wagner's music in the audience, both Wagnerians and unprepared spectators, making the second group even more risky in terms of reception, since it is not able to understand the irony, humour and paradoxes often included in post-modern Wagner productions. However, we have to be careful, when we deal with ignorance and trivialization in stage director's concept, when he claims that the plot is old-fashioned or hardly understandable which might be the case of "Lohengrin" staged by Latvian stage director Andrejs Žagars in Vilnius. Relocating the epic story of the plot to the beginning of the 2<sup>nd</sup> World War (1940) in Vilnius, using the Cathedral of Vilnius for set design and transforming Lohengrin into a commando, who sings "Mein Lieber Schwan..." to a warplane, Žagars claims to "*present to the audience a very vivid, human story. I had no wish to tell a*

*story about divine entities and super-humans. My goal is to help people enjoy the magic of Wagner's music without any disturbance."* (Zagars, 2013)

As for the supposed prevalence of music over other compounds of opera, there is a paradox about Wagner's music dramas precisely described by the distinguished Wagner scholar Barry Millington:

*"But that centre of gravity [of Wagner's works] is itself disputed. If you ask many a passionate Wagnerian what means most to them, they will say 'the music'. They would be content to banish all visual and theatrical distractions, the better to immerse themselves in the warm bath of voluptuous sonorities. Stage production is at best an irrelevance for such people, at worst an irritating distraction. Wagner himself would have been appalled by such self-indulgence. For him, the music drama was a vehicle to make a statement about the world around him and about how it could be improved. The music acted as the fuel to fire the engine."* (Millington, 2013)

So, the idea that music should rule and everything else should be subject to it, is not really correct, despite a great deal of the emotional effects of Wagner's operas undeniably is created by his highly symphonic and fascinating scores. What makes Wagner's music dramas topical apart from the bicentenary of their author today? Maybe it is the mood of the liberal 21<sup>st</sup> century without fixed system of values, including cultural values, when the routines prevail over the ideals. In terms of art, maybe it is longing for "ideal art" that can change people and to wake the emotional side of fully rationalized life. Yet, the concept of "ideal art" in relation to Wagner's heritage is covered by different stereotypes in terms of expectancies of the audience. At least, such a hypothesis can be based on mainly negative reactions in the society after the premiere of, for example, "Götterdämmerung" by Viesturs Kairiņš in Latvian National Opera, where he ironically portrays Brünnhilde and Siegfried as hippies – a representation of "the other" - among the mass, whose dresscode is conditioned Soviet 70ies and where Siegfried meets his death from Hagen's spear, which is used during the "haunting scene" as a spit for sausage roasting.



Generally, main reproaches of the audience are directed to the new interpretations by stage directors, since they open new dimensions and largely deal with collective past traumas and grotesques of today's reality (for instance, Frank Kastorf's Ring in Bayreuth festival this year, where the Rheingold is represented as oil and the rest of the plot rotates around the war for oil resources) But, nevertheless, the stage directors are responsible for the "engine", if we use a term chosen by Barry Millington, of the production, the drama, the changeable part of opera performance and the guarantee of the sustainability and long-term development of the

genre. In case of Wagner's operas, whether the production complies with the concept of the "Gesamtkunstwerk" or the total work of art, the synergy of all arts in a musical drama or distorts it partially or completely is stage director's choice and responsibility. The stage director must be ready to compete with his message and story with Wagner's self-created fundamental mythological system based on German and Scandinavian myths and legends. Let's see different examples of how stage directors reflect on the topic. Famous Lithuanian stage director Eimuntas Nekrošius at the time of staging "Die Walküre" in 2007 has stated the following:

*"I can't understand the world of contemporary opera productions, everything there is broken and distorted. Opera is losing its sanctity. No one has a right to violate the tradition, because traditional opera has so much charm. Of course, we are living in different times now, so we have to clean off the dust, brush away the spiders' webs – all this needs to be done with great care. [...] The most important task given for every opera director is to let the music flow. It is so hard to restrain yourself, to have limits. It is important to keep the moderation. Music in itself is very eloquent - the director only accommodates it with the visual space. Director is the translator of music."* (Nekrošius, 2007)

*Latvian stage director Viesturs Kairiņš, who has interpreted last three of the "Ring" cycle operas in Riga, in his turn, to the question about the "end problem" of the "Götterdämmerung", the supposed apocalypses, where the world of gods and men dies in flames and flood, but nothing alike happens in his production, where it all ends with a choir singing a mute anthem behind all dead bodies of the main characters, says:*

*"If I see a burning rock, it seems to me an artificial property. The total work of art by Wagner today can be, of course, interpreted as a synergy of technologies involved in opera production like, for instance, video and similar visual effects, but I feel the Gesamtkunstwerk more as connection in manner of thinking. Despite the high-quality expensive burning rock on the stage, I would opt for emotion caused by the relationship of the protagonists. I am interested in translations of Wagner's works, of how can we percept his ideas today".* (Lusina, 2011)

What we see here, both stage directors use the word „translation" to describe their job for Wagner's opera productions. Opera critic Michael Amundsen, writing about the recent Daniel Slater's production of „Tannhäuser" in Estonian National opera puts the question slightly modified: „Wagner's music is undeniably sublime, but are the moral sentiments of his works relevant to contemporary life?" (Amundsen, 2013). The stage directors choosing the postmodern approach to make an opera production often try to reach the audience and translate the archetypical models of relationship and resolve, for instance, the perpetual contradiction between power and love using the symbols familiar to their contemporaries.





Despite the opinions of the aforementioned directors differ, we can both agree to the statement of Nekrošius that classical operas, and especially Wagner, should be dealt with great care, and also to Kairiss that excessive props like Viking helmets, furs and burning rock in video do not necessarily mean the fulfilment of author's intentions. The translation here runs deep into the constantly transforming space of symbols and meanings, and contexts. Stage director of Wagner operas in 21<sup>st</sup> century should be a creative translator, who creates new meanings adds new contexts without losing core ideas of Wagner, which have nothing to do with one or another fixed period of time. We (including stage directors) cannot turn back to the end of the 19<sup>th</sup> century and to see Wagner's music dramas in a way he and his contemporaries saw it, because we cannot ignore our historical and cultural experience that covers more than 150 years after Wagner and exclude it from our perception. Certainly, there are more successful "translations" and failures among contemporary opera productions, including Wagner operas, but none of them deserves a self-righteous judgement that "this is not Wagner" before deeper semantic and semiotic analysis, considering the contexts applied by the stage director and their impact to the general message of the production.

### Conclusion:

The contemporary productions of Wagner operas in the 21st century are mainly interpreted via postmodern approach adding new contexts to the archetypal stories. Drama or stage version of the opera is the only changeable compound of the opera genre that ensures the sustainability of the genre in terms of expectances of opera goers, at the same time attracting new audiences. Wagner's operas today are mainly interpreted via *Regietheater* or director's theatre that allows adding of different meanings and contexts to the original plot, bringing it closed to the audience through recognizable symbols and values.

### References:

- Amundsen, Michael. *Review of the premiere of „Tannhauser“*. Tallin Arts, 14.03.2013, <http://www.the-wagnerian.com/2013/03/review-estonian-national-opera-premiere.html>,  
 Bartlett, Rosamund (1995./2007) *Wagner and Russia*. Cambridge University Press, NY:USA.  
 Lūsiņa, Inese, *Wagner does not let you go. Interview with Viesturs Kairiss*, Diena, 17.11.2011., <http://www.diena.lv/kd/intervijas/vagners-tevi-neatlaiz-13915794>,  
 Millington, Barry (2013) *200 years not out*. Paper presented in the conference „Richard Wagner's Impact in His World and Ours”, Leeds, UK, May 30-June 2, 2013.  
 Nekrošius, Eimuntas, excerpts from the interview, <http://www.opera.lt/en/performances/opera/die-walkre>

Salmi, Hannu (2005). *Wagner and Wagnerism in Nineteenth-Century Sweden, Finland and the Baltic Provinces. Reception. Enthusiasm.* Eastman Studies of Music, University of Rochester Press, NY:USA.

Zagars, Andrejs, quote from the press conference before the premiere of his production of „Lohengrin” in Lithuanian National Opera and Ballet Theatre, <http://www.opera.lt/en/news/lnobt-welcomes-the-premiere-of-richard-wagner-s-mysteriouslohengrin>.

# METEOROLOGICAL AND HUMAN FACTORS INFLUENCE ON LEACHATE DYNAMICS

*Vilda Grybauskiene, Dr.*

*Gitana Vyciene, MA*

Aleksandras Stulginskis University, Institute Of Water Resources Management, Lithuania

---

## Abstract

The more urbanized society is, the larger the volumes of waste generated, and more problems are associated with their management. The aim of this article is to analyze Jarubaičiai landfill leachate generated content and dynamics of the factors causing this problem. This article analyzes Jerubaičiai landfill leachate resulting from the dynamics of the exchange of meteorological conditions and therefore increasing the amount of waste. This study was carried out from 05/15/2008 to 12/31/2008. The reference periods covers all seasons and are representative of Sightseeing meteorological conditions. Throughout the year, 6500 m<sup>3</sup> leachate is formed at the Jerubaičiai landfill. The study found that during the year the amount of waste was 1050 tons of waste per week. The landfill is covered by approximately. When the average air temperature is about - 10 °C, the leachate recycled content ranges from 40 to 140 m<sup>3</sup>. At the average temperature of 0 °C the leachate recycled content ranges from 250 - 270 m<sup>3</sup> of leachate. During winter when the temperatures are below 0°C, 250-270 m<sup>3</sup> of leachate transpires through the pile of waste. In summer, the total amount of precipitation was 52%, and the amount of leachate setting-up to only 23% of the total filtrate. Correlation between air temperature and leachate  $r=0,784$ . It shows that air temperature strongly affects the amount of extracted filtrate. It was concluded that when the amount of waste in landfill increases, the amount of leachate discharged also increases at  $r = 0.641$ .

---

**Keywords:** Waste, leachate, waste management

## Introduction:

Human activities are inevitably associated with the generation of waste. The more urbanized society is, the larger the volumes of waste generated, and more problems are associated with their management. Landfill leachate, is problem of growing generation at cities and relevant environmental problem. Landfill leachate is characterized by high BOD<sub>5</sub>, it is also have a big concentration of heavy metals and organic compounds (Kaunelienė and Gelažienė, 2002). Landfill leachate collection and treatment at Lithuania and the EU is pressing problem because of treatments prices, technology, and the most appropriate site selection. Leachate ie full of the chemical composition of various landfill wastes varies depending on waste age, the degree of compression, waste type, and landfill shape and height of the average the air and slag temperature, precipitation, humidity (Barber and Maris 1984, Crawford and Smith, 1985).

According to Jeskelevičius and Lynikienė (2009) on the landfill volume occurring physical, chemical and biological reactions occur both in the landfill gas is also harmful to the leachate. Because of the lack of supervision and control - landfills with household waste within industrial, biodegradable or even hazardous waste leachate observed a large quantity of toxic compounds, and maximum steady groundwater pollution sources. Especially for those of landfill sites who have not necessary protective measures. Here the most important ground water chemical composition of the formation factor is the leachate (Williams, 2005). Our

conditions of high concentrations of chemical components in the leachate can form more than 20-30 years after the closure of landfills and liquid pollutant pathways to 1.5-2.0 km from the site (Williams, 2005). Crawford and Smith (1985) found that the seasonal and climatic features have a direct impact on leachate composition and key environmental factors inducing the biological decomposition of landfill waste is considered the temperature and humidity. The optimum moisture content of the landfill should be approximately 40%. The moisture content of less than 40 % is identified as a factor would reduce the biological activity of the heap and is therefore observed BOD<sub>5</sub> concentrations were decreased (Hamoda et al., 1998; Renou et al., 2008). Frank and others (2002) suggest that the ambient temperature has a similar effect on leachate migration, since most of the landfill bacteria are anaerobic, they preferred a constant temperature between 20 and 40 ° C and the seasonal change in temperature can reduce the biological activity of waste degradation and therefore may reduce leachate release (Crawford & Smith, 1985; Hamoda et al., 1998). Leachate release to the environment is influenced by many cases. They change the concentrations and emission levels. This study aims to determine the meteorological conditions and volume of waste impact the landfill leachate dynamics.

## Methodology

The leachate sampling was performed in a landfill leachate storage reservoir of municipal solid waste landfill in Plunges district. The landfill is 0.8 kilometers away from Plunge-Medingenai road. This landfill is the only one left in the Telsiai district. It serves Plunge, Rietavas, Mazeikiai, Telsiai regions. Currently, there are six sections for the waste to be accumulated. The waste, when it comes at the landfill, is accumulated in sections. When the waste is decomposing, the leachate forms which are gathered by the leachate-drain systems collected underneath the pile of waste. The leachate gathered later gets into the storage reservoir. From here it often is pumped up into the leachate cleaning equipment. The cleaning of the leachate happens in reverse of the osmosis after which forms the condensate and water. The condensate formed is returned back to the top of the pile of waste, and the already clear leachate, like water, is let out to the bio storage reservoirs, from which later gets into the nearby canal Fig. 1. Throughout the year, 6500 m<sup>3</sup> leachate is formed at the Jerubaičiai landfill.

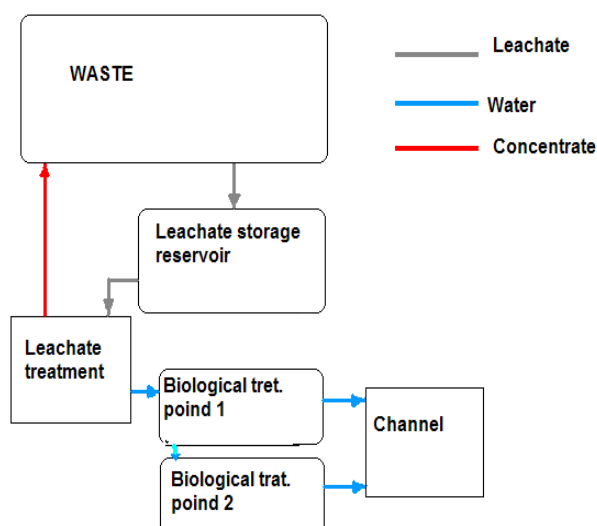

Fig. 1. Filtrate cleaning chart of the Jerubaičiai landfill

The leachate from the leachate storage reservoir is served in the ring whirl in which when a certain amount of HCl is added, the filtrate reaches the necessary ph 6.5. The leachate is mixed and circulated by the vacuums in leachate storage reservoir, until it reaches the necessary ph level. From the ring whirl the leachate is sent by the vacuum through a re-

filtering system, which consists of sand and special cassette filters. The reverse osmosis principle applies in all of leachate's processing equipment stages. If half conductive membrane, which allows through only a certain size particles, divides two sodium solutions or contaminated liquids, the concentration then equalizes. In the reverse osmosis modules the process takes part when the filtrate moves through the membrane's surface. Unclean leachate's concentration is slowly increases when the water runs through the module. The waste is filtered through and is left behind the membrane. So called "concentrate" is taken out. The strained clean water flows into the water reservoir. *The ascertainment of the amount of cleaned filtrate.* There is a mounted meter put in order to observe this process. *Waste excess formation and the calculation of the trash brought into the landfill.* The scales are used in order to determine the amount of waste brought in. Data alteration of meteorological changes at the Jerubaiciai landfill was determined according to the Telšiai district meteorological center's observation journal.

**Results and their discussion**

*The analysis of the dynamics of the environmental temperature's data.* When establishing the effect of the meteorological conditions to the leachate, it is necessary to study their dynamics during that period. The data is received from the meteorological stations' database. The average weather temperature dynamics was fixated every Monday and Thursday at 7 o'clock in the morning. The final results can be seen below (Fig. 2).

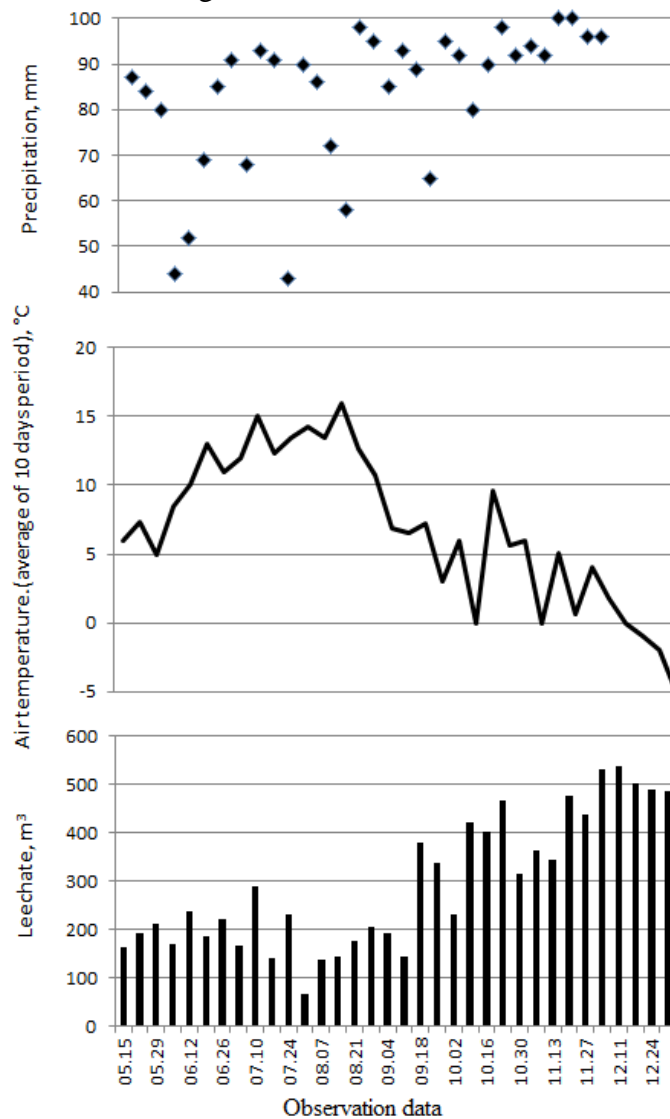

Fig. 2. The dynamics of the climatic conditions at research period

This data is compared within itself. During warm period from 2008 May 15 until 2008 September 15 when the temperature is 10°C at 7 o'clock in the morning the cleaned leachate dimension is fluctuating from 40 to 140 m<sup>3</sup>. When the temperature decreases, the level of the cleaned leachate begins to increase. During winter when the temperatures are below 0°C, 250-270 m<sup>3</sup> of leachate transpires through the pile of waste. From this graph (fig. 2) is seen that cooler weather affects the increase in the amount of leachate.

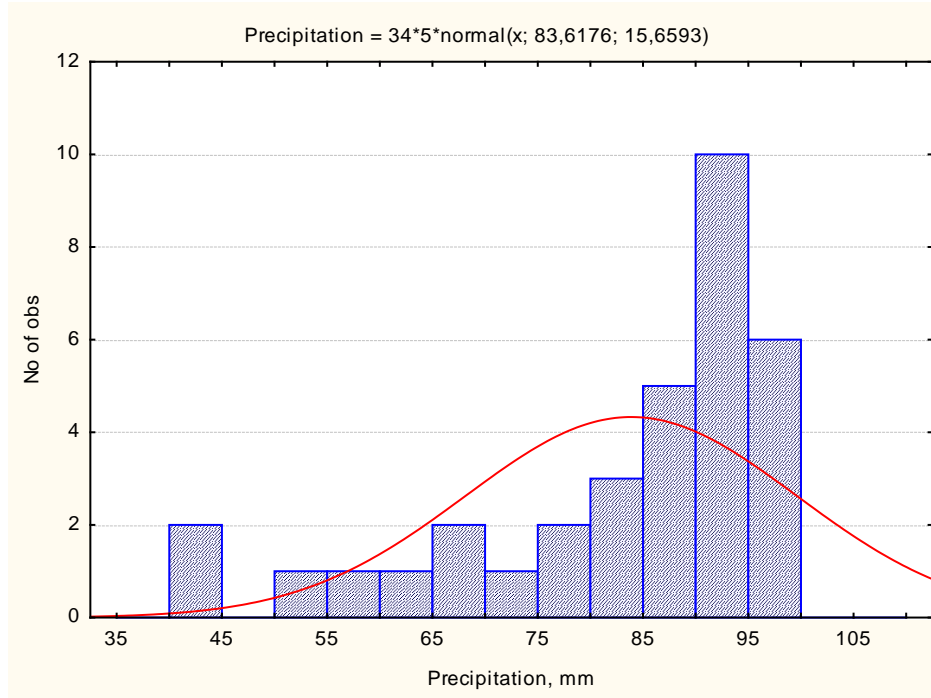

Fig. 3. Precipitation histogram of observation period and density function

Correlation between air temperature and leechate  $r=0,784$ . It shows that air temperature strongly affects the amount of extracted filtrate. More statistical data are presented at table1.

Table 1. Statistical data of research results

	Valid, N	Mean	Min	Max	Stand. Dev	Standart. error	T- value	df	CORRELATION	Leechate	Temperature	Precipitation
Leechate	34	29,42	66	537,0	138,58	23,76	12,37	33		1	-0,78	0,45
Tepperature	34	6,90	-5	15,9	5,47	0,93	7,355	33		0,78	1	-0,43
Precipitation	34	83,17	43	100	15,65	2,68	31,13	33		0,45	0,43	1

***Influence of precipitation for the formation of the filtrate.*** In the landfill, the leachate forms when the precipitation and water from the melting snow filtrates through the waste. Leachate is one of the main environmental problems associated with the clearing of the landfill because it has toxins such as organic materials, heavy metals and mineral oils which could harm water quality both underground and on the surface (Amokrante, 1997). According to the schedule of the amount of precipitation, the changeable dynamics of precipitation is being fixed. During warm periods most precipitation falls between the months of June and July-80-93 mm, and least-only 38 mm in May. In October there can also be seen clear increase in precipitation - 81 mm. When analyzing data from 2008 (Fig. 3.), it can be seen that most precipitation fell during the months of June and July. When observing the dynamic of amount of leachate. It is seen that during the research period the amount of leachate

decreases. Heat extracts in the pile of waste during the process of disintegration. There is around 60 °C temperature 3 meters deep underground independently from the season of the year. It allows us to come up to a conclusion that precipitation in the summer evaporates and therefore the amounts of leachate are lower. In the fall there is higher amount of leachate extracted. That means that smaller amounts of precipitation is evaporated. The most leachate is extracted in winter, when the amount of precipitation is lower. This data differs from the average amount of precipitation in Lithuania. They are registered in Plunge district where climate is more humid. The relative air humidity is directly dependent from the amount of precipitation. During warm periods, from 2008 May 15 to 2008 September 15, the relative air humidity is lower and less leachate is formed in the landfill. The relative air humidity minimums were registered four times during the research period that is May 3-18, July 24-30 and August 24-31. The relative air humidity stays high at the end of fall and all winter long because humidity does not evaporate as quickly during lower temperatures. If we would analyze the amount of materials dissolved in the leachate during that time, we would see that it increased during the chosen period. From this we could make a presumption that if air's relative humidity is lower, the amount of materials dissolved in the leachate, which ends up in the mechanisms of the reverse osmosis, is higher. During the period when the relative air humidity is lowest, and when the amount of materials dissolved in it is higher, more concentrate is formed at the time of leachate's cleaning. The leachate is sent to the cleaning installation at the same diversion rate of 3200l/h. Because the system cleans itself automatically each 120 hr, the work of the installation can be kept steady. The decrease of the amount of runoff water is observed at the end of July. This decrease of the cleaned leachate was influenced by the existing high temperatures and low level of precipitation. The amount of the runoff water reaches 100-200 m<sup>3</sup> during the months of July-August. Constant increase from 200-450 m<sup>3</sup> per week is seen in autumn months, when the temperature decreases and the relative humidity is higher. A slight dependency was determined when analyzing the influence of air humidity to the contamination of filtrate. Correlation coefficient is  $r=0.473$ . However, not a strong dependency was determined between air humidity and the amount of filtrate.

**Leachate cleaning data.** The landfill serves Telšiai county citizens and factories which have decreased their production levels. Such dynamics of the amount of waste influences the amount of particles dissolved in the leachate which is registered by the distinct electrical measuring instrument. Measurements were started in the middle of May and at that time the measuring instrument showed around 630 S/cm. Much higher meanings are registered during the summer months. The biggest registered meaning is July 27, even 1008 S/cm. Such a high increase in the amount of particles may have been caused by the constant high temperatures and low level of precipitation. During the existing high temperatures, the reactions in the pile of waste become more active.

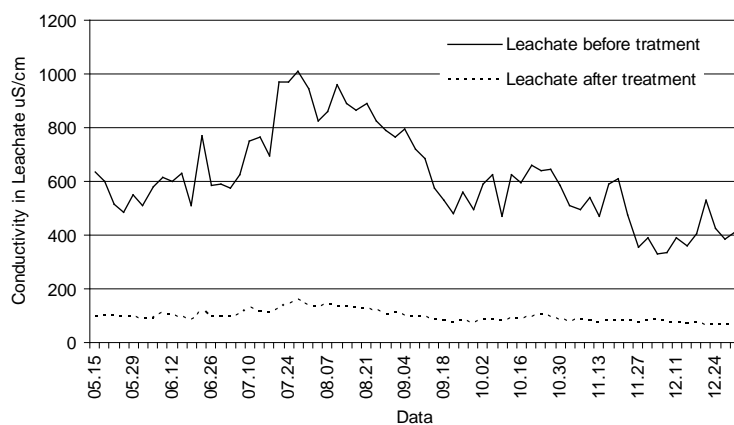

Fig. 4. The dynamics of the leachate conductivity before and after cleaning

When further observing changes it was determined that when the summer season ends and temperatures drop, the amount of dissolved particles decreases. In the beginning of the fall the amount of dissolved particles in the leachate is from 500-650 S/cm. Such numbers stay throughout almost all fall. The changes in them are noticed at the end of fall when air temperature drops below 0°C. During that period the amount of dissolved materials is lower than 400 S/cm. During steady temperature our received meanings also slightly fluctuate. When noticing even the smallest change in temperature, the leachate is also seen as changing. When analyzing cleaned leachate's conductivity we can see (Fig. 4.) that the received results are also not steady. In May it is around 90-100 S/cm and stays as such until the summer. From the earlier discussed graph we already know that in summer during the increase in temperature the leachate got into our previously discussed leachate cleaning installations in which the amount of dissolved particles was higher. So when observing already cleaned leachate we can see that the contamination level is increasing, and the biggest meaning is noticed on July 27, and that is 160 S/cm. The leachate's average conductivity in summertime is registered at around 110-140 S/cm. The amount of dissolved materials decreases only when the fall comes. We also registered that throughout almost all fall the changes stay still, at 70-90 S/cm. The only increase is registered in the middle of October. The already cleaned leachate data schedule seems to follow the schedule of the cleaning of leachate. From this we can conclude that there is a direct dependency between both data. Such effect could have been influenced by the changes in air temperature. When there is a higher level of contamination of leachate, which is affected by the higher temperatures, the efficiency of the filtration increases. When processing the data statistically, we determined that the average meaning of the conductivity in the leachate before cleaning is 725 S/cm, standard error -154, after the cleaning the average meaning-112 S/cm, standard error-19,5.

**The analysis of the amount of waste delivered.** The amount of waste in the landfill is always changing. Such instability is affected by the inconsistent use of consumption. This also depends on the season of the year and State holidays. As seen in the fig 8, the amount of waste brought in constantly increases. Currently, around 1050 tons of waste per week gets into the landfill. Fig 8. shows until July the amount of waste brought in was from 850-950 tons per week. From July 1, 2008 Jerubaiciai landfill became the only household waste type of landfill working in Telsiai district. An increase from 950 to 1050 t of waste per week has already been noticed. At the end of December the amount of waste is registered at the increase of 1130 t. This was due to Christmas period when the consumption increases. Comparing the dynamics of the amount of waste brought in to the landfill with the dynamics of the formed filtrate, it was determined that there is a tendency for increase (fig. 5).

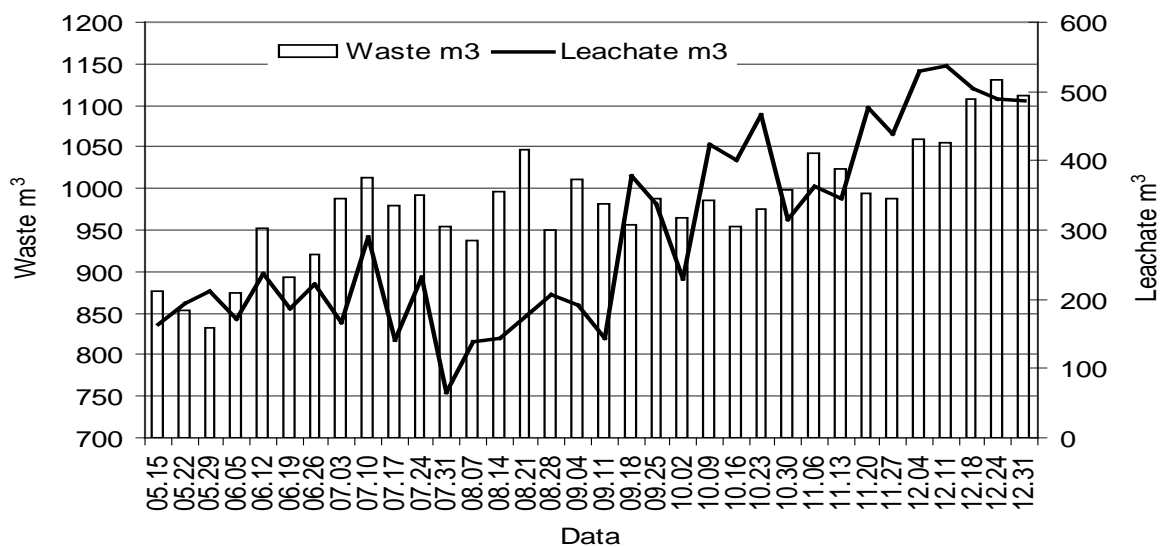

Fig. 5. Dynamics' of the amount of waste brought in to the landfill



Waste brought in to the landfill often times is already rotten and its disintegration has already begun. Therefore, when the waste gets into the pile of the existing waste, the extraction of leachate intensifies. After the analysis of the statistical data, it can be seen from Fig. 5 that when the amount of waste brought in to the landfill increases, the amount of leachate formed in the landfill also increases. These increases are dependent from one another. The data has been amended during the existing reliability level  $p=0.0001$ , also 34 measuring data was examined, and it was determined that the standard error between measurements of the amount of filtrate is 138.5, and between dynamics of the amount of waste brought in is 69.2. When analyzing the increase in the amount of waste and the dynamics of the leachate extracted, it was determined that this data is dependent from one another (Cureton et. All., 1991). The dependency was determined during the existing level of reliability  $p=0.0001$ . The average of 294 m<sup>3</sup> of leachate is extracted and 982 t of waste is brought into the landfill during the week. The average strength correlation is determined between them, and that is  $r=0,641$ . It allows us to form a conclusion that when the amount of waste increases, the amount of filtrate also increases.

### **Conclusion:**

Meteorological conditions affect the dynamics of the leachate in landfills. During the day's higher average temperatures the amount of leachate decreases, and during lower temperatures-increases. During lower relative air humidity less leachate is formed, and when the humidity increases, the amount of leachate increases. When the average air temperature drops below 10 °C, the amount of leachate increases. A strong correlated dependency has been determined between air temperature and the amount of leachate extracted.

During research most levels of precipitation have been registered in the months of June-July, but there was no increase in the amount of leachate. Precipitation from the summer evaporates from the pile of waste and does not get into the system of leachate gathering.

When the relative air humidity decreases, higher amounts of dissolved materials are registered, that is, the concentration of leachate pollution increases because less leachate is formed.

The amount of leachate depends on the amount of waste brought in to the landfill. When the amount of waste increases, the amount of leachate proportionally increases as well. The dependency has been determined between the increase in the amount of waste in the pile and the extracted leachate. Regression coefficient is  $R=0,41$ . It shows that when we pour waste into piles, we will need to take care of the large amounts of leachate that forms.

The filtrate is cleaned better when filtrate's conductivity is bigger and when the average air temperatures are higher.

### **References:**

- Amokrane, A., Cornel, C., Vernon, J. 1997. Landfill Leachates Pretreatment by Coagulation-Flocculation, *Water Research*. 31(11) 297-336.
- Baber, C., Maris, J., 1984. Recirculation of Leachate as a Landfill Management Option: Benefits and Operational Problems. *Quarterly Journal of Engineering Geology and Hydrogeology*, first published on February 1984, v. 17:19-29
- Crawford, JF., Smith, PG. 1985. *Landfill Technology*, P - 159
- Cureton, P. M., Gronevelet, P. H., McBride, R.A. 1991. Landfill Leachate Recirculation Effects on Vegetation Vigor and Clay Surface Cover Infiltration. *Journal of Environmental Quality*, Vol. 20, pp. 17-24,
- Frank, K. *Handbook of solid waste management*. e-knyga. New York : McGraw-Hill:. 2002.
- Hamoda M.F.,Adu Qdias JN Evaluation of Municipal Solid Waste Composting Kinetics, *Resources, Conservation and Recycling* 23 (1998) 209 – 223.

Hoilijoki, T.H., Ketunnen and J.A. Rintala, Nitrification of Anaerobically Pretreated Municipal Landfill Leachate at Low Temperature, *Wat. Res.* Vol. 34, No. 5, (2000) 1435 – 1446

Jaskelevicius, B., Lynikiene, V. Investigation of influence of lapes landfill leachate on ground and surface water pollution with heavy metals. *Journal of Environmental Engineering and Landscape management.* Volume 17, Issue 3. 2009. P- 131-139

Kaminskas M., Diliunas, J., Čyzius, G., Karveliėne, D, Zuzevi2ius, A., 2004. Požeminio ir paviršinio vandens apsauga buitinių atliekų sąvartynų aplinkoje. *Vandens ūkio inžinerija, Mokslo darbai* 26 (24), 87–92.

Kauneliėne, V., Gelaziėne, L. Sunkiujų metalų migracija į karklų žilvičių (*Salix viminalis*), naudojamų sąvartyno filtrato valymui, audinius Aplinkos tyrimai, inžinerija ir vadyba, 2002.Nr.2(20), P.49-56 ISSN 1392-1649 *Environmental research, engineering and management*, 2002.No.2(20), P.49-56 *1 pastraipa*.

Renou S., Givaudan, J.G. Poulain, S., Dirassouyan, F.,Moulin,P. Landfill leachate treatment: Review and opportunity, *Journal of Hazardous Materials* 150 (2008) 468 – 493

Williams, T. Waste treatment and disposal. Second edition. John Wiley and sons, LTd. England:. 2005. p – 375

# STUDY OF THE EFFECT OF CYANO SUBGROUP ON THE ELECTRONIC PROPERTIES OF AZULENE MOLECULE: B3LYP-DFT CALCULATION

*Ghaidaa. A. Hafedh Jaber*  
*Basim Abdullattif Ghalib*  
*H. I. Abbood*

---

## Abstract

Theoretical study of the effect of cyano subgroup on the electronic properties of azulene molecule was performed using DFT with B3LYP/6-31(d,p) basis set. The optimized structure, total energies, electronic states, energy gaps, ionization potentials, electron affinities, chemical potentials, global hardness, softness, global electrophilicity, dipole moment and dipole polarizability were calculated. The harmonic vibrational frequencies were calculated and compared with available experimental data. The results showed a decrease in energy gap and improve the electronic properties for the new structures.

---

**Keywords:** DFT, Ionization potential, electron affinity, energy gap, and IR spectrum

## Introduction

Aromatic compounds are important in industry and play key roles in the biochemistry of all living things [1]. Cyano-substituted aromatic molecules are members of a class of environmental contaminants found in airborne particulate matter, fossil fuel combustion products, coal fly ash, cigarette smoke, and vehicular emissions, formed by reactions of aromatic molecules with nitrogen oxide [2]. The organic semiconductor materials, such as, conjugated organic molecules have been widely used as active materials for optoelectronic devices such as light emitting diodes [3-5], field effect transistor [6-9], and photovoltaic and solar cells [10,11]. These materials have advantages of easy fabrication, mechanical flexibility and low cost. The organic thin film transistors are one type of the so called organic devices, in which they are fabricated by using the organic semiconductors [12]. There are many organic materials that show useful field effect transistor performance, which can be characterized by their carrier mobility and on/off current ratios [13, 14].

Various studies on cyclic oligomers have been reported both experimentally and theoretically [15, 16], in [17] the substituent effects of oligomers such as oligothiophene, oligopyrrole and oligofuran are discussed in terms of reorganization energy. So, [18] studied the geometric and electronic properties for cyanothiophene oligomers as a prototype of an organic conducting polymer using *ab initio* and DFT [19], they showed that the cyano group generally reduced the band gap with variation of the substitution position.

Azulene molecule and its derivatives have been studied in this work. Therefore the main aim of this work is to examine the cyano group substituent effect on azulene molecule varying the number of the substituent in the molecule.

## Theory and computational details

The structures of the molecules under study in this work are shown in figure 1. All the computational studies were carried out using the density functional theory (DFT) methods implemented in the Gaussian 09 suite of programs [21]. The molecular properties of the

compounds had been computed by DFT using the standard 6-31G(d,p) basis set. Lee-Yang - Parr correlation functional [22] is used together with Becke's three parameters[23]exchange functional B3LYP. Conformational analysis of the molecules had been performed to have an idea about the lowest energy structures of the species.

The geometrical structure was performed at the B3LYP density functional theory with the same basis set [22,24]. Harmonic vibration frequencies were computed at the same level of theory. The hybrid functional B3LYP has shown to be highly successful for calculation the electronic properties such as ionization potentials, electronic states and energy gaps [25-27].The electronic energy as, where  $E_T, E_V$ , and  $E_J$  are the electronic kinetic energy, the electron nuclear attraction and the electron-electron repulsion terms respectively. The electron correlation is taken into account in DFT due to the exchange correlation term  $E_{xc}$ , which includes the exchange energy arising from the anti-symmetry of the quantum mechanical wave function and the dynamic correlation in the motion of individual electrons; it makes DFT dominant over the conventional HF procedure [28].

The geometry optimized structures are obtained by restricted closed-shell formalism and without any symmetry restriction, and vibration analysis for each structure does not yield any imaginary frequencies, which indicates that the structure of each molecule corresponds to at least a local minimum on the potential energy surface[29]. In this investigation, the more relevant electronic potential (IP), electron affinities (EA), chemical potential ( $\mu$ ) (the negative of electronegativity ( $\chi$ )), hardness ( $\eta$ ), softness (S),electrophilic index ( $\omega$ ) and the electric dipole polarizability ( $\alpha$ ) were calculated. The ionization potential is calculated as the energy difference between the energy of the molecule derived from electron-transfer and the respective neutral molecule;  $IP_v = E_{\text{cation}} - E_n$ . The EA was computed as the energy difference between the neutral molecule and the anion molecule:  $EA = E_n - E_{\text{anion}}$  [30]. The HOMO and LUMO energy was also used to estimate the IP and EA in the framework of Koopmans' theorem:  $IP = -\epsilon_{\text{HOMO}}$  and  $EA = -\epsilon_{\text{LUMO}}$  [31].

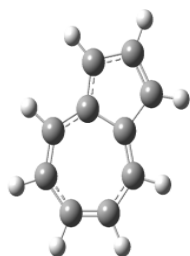

Azulene

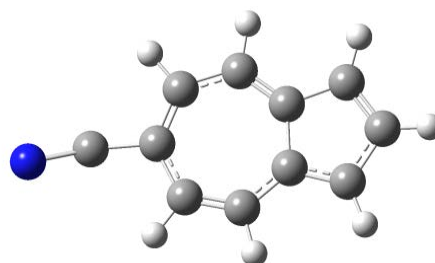

mono-cyano azulene

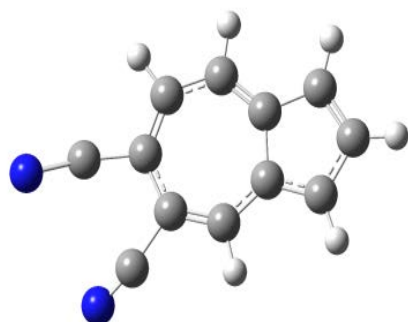

di-cyano azulene

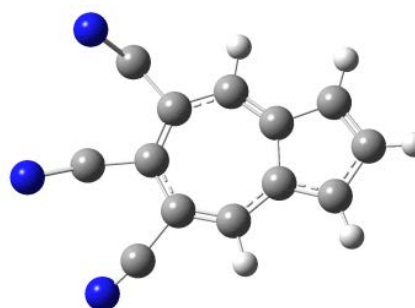

tri-cyano azulene

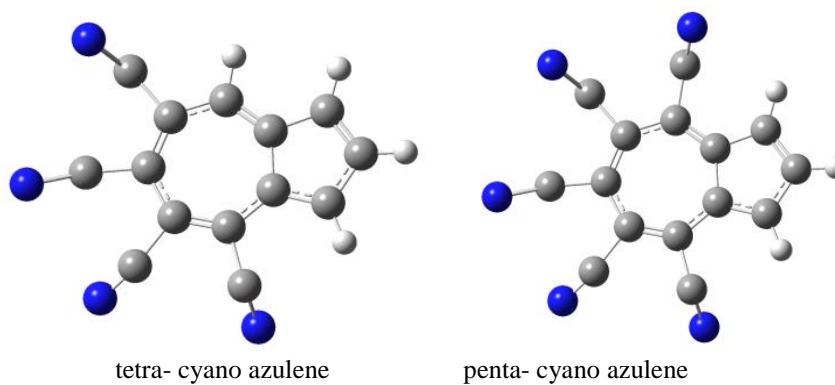

**Figure 1.** Geometrical structures of the studied molecules

In the density functional theory (DFT), one of the global quantities is chemical potential ( $\mu$ ), which is measures the escaping tendency of an electronic cloud, and equals the slope of the Energy versus N(number of electrons) curve at external potential  $v(r)$ [32]:

$$\mu = \left[ \frac{\partial E}{\partial N} \right]_{(v)} \quad (1)$$

The finite difference approximation to Chemical Potential gives,

$$\mu \approx -\chi = -\frac{IP + EA}{2} \quad (2)$$

The theoretical definition of chemical hardness has been provided by the density functional theory as the second derivative of electronic energy with respect to the number of electrons N, for a constant external potential  $v(r)$  [32]:

$$\eta = \frac{1}{2} \left[ \frac{\partial^2 E}{\partial N^2} \right]_{(v)} = \frac{1}{2} \left[ \frac{\partial \mu}{\partial N} \right]_{(v)} \quad (3)$$

The finite difference approximation to Chemical hardness gives,

$$\eta = (IP - EA)/2 \quad (4)$$

The softness is given as [31] :

$$S = \frac{1}{2\eta} = \left( \frac{\partial^2 N}{\partial E^2} \right)_{(v)} = \left( \frac{\partial N}{\partial \mu} \right)_{(v)} \quad (5)$$

The electrophilicity index is a measure of energy lowering due to maximal electron flow between donor and acceptor. Electrophilicity index ( $\omega$ ) is defined as [28],

$$\omega = \frac{\mu^2}{2\eta} \quad (6)$$

One of the other global properties is the electric dipole polarizability, which is a measure of the linear response of the electron density in the presence of an infinitesimal electric field, F, and represents a second-order variation in the energy, viz.[32] :

$$\alpha = - \left( \frac{\partial^2 E}{\partial F_a \partial F_b} \right)_{a,b = x, y, z} \quad (7)$$

If some of applied molecules are planar and some are not, it will be useful to report polarizability quantities that are invariant to the choice of coordinate system. One of them is the mean polarizability  $\langle \alpha \rangle$  is evaluated using the equation [28].

$$\langle \alpha \rangle = \frac{1}{3} (\alpha_{xx} + \alpha_{yy} + \alpha_{zz}) \quad (8)$$

Where  $\alpha_{xx} \leq \alpha_{yy} \leq \alpha_{zz}$  are the eigenvalues of the polarizability tensor.

## Results and discussion

### I. Energies.

Table (1) shows the values of the total energy and electronic states and the energy gap ( $E_{LUMO} - E_{HOMO}$ ) of the studied molecules. The total energy for all studied molecules as a linear function of CN side group number adding to the azulene molecule. The final total energy of the product is the collection of total energy of all small molecules which build the product molecule, that means:

$$E_{tot} \approx E_{tot}(\text{azulene}) + nE_{tot}(\text{CN}) \quad (9)$$

Where n is the number of CN radicals.

It is clear that from Table 1, the total energy for all mentioned molecules are small when compared with the original azulene molecule, and the substitution of cyano groups causes decreasing the HOMO and LUMO energy [34], and energy gap decreased. Therefore, the presence of substituent decreases the energy gaps improves the conductivities and also enhances the solubilities of these molecules.

The LUMO-HOMO energy gaps of cyano-azulene molecules are less than that of the original molecule, with decreasing energy gap, electrons can be easily excited from the ground state [35,36]. This effect of the side group was the largest in molecule No.6 it has energy gap of (2.524 eV). The energy gap of azulene (3.324 eV). The table 1 shows also the symmetry of studied molecules, the molecule 1 is planar with inversion center and have  $C_{2v}$  symmetry (high symmetry), and have lower electronegativity, while molecule 6 is planar and have  $C_1$  symmetry (low symmetry), and have higher electronegativity. The results showed that the energy gap here is a linear function to the cyano subgroup adding to the molecule.

**Table1: Total energy, electronic states and energy gap for molecules**

Structure	Energy(a.u)	Symmetry	Electronic States(eV)		Energy Gaps (eV)
			HOMO	LUMO	
1	-383.7826	$C_{2v}$	-5.594	-2.270	3.324
2	-461.1120	$C_s$	-5.292	-2.081	3.211
3	-536.3485	$C_s$	-5.295	-2.190	3.105
4	-611.5643	$C_s$	-5.245	-2.201	3.044
5	-686.7933	$C_s$	-5.004	-2.112	2.892
6	-762.0060	$C_1$	-5.005	-2.481	2.524

### II. Some electronic variables.

B3LYP density functional theory used in this work has a high efficient to calculate the electronic properties for the organic studied molecules, such as ionization potentials(IP), electron affinities(EA), electronegativity ( $\chi$ ), absolute hardness( $\eta$ ), absolute softness (S), electrophilic index ( $\omega$ ). The properties that are displayed in table 2 for each variable are computed by adiabatic method only, in which the two different ways used in the calculation are : The first one being energy-vertical is based on the differences of total electronic energies when an electron is added or removed in accordance with the neutral molecule. The second one is based on the differences between the HOMO and the LUMO energies of the neutral molecule and is known as orbital-vertical (Koopmans' theorem). The calculated properties for each variable as shown in table 2 clearly reveal that these compounds have a tendency to capture electrons instead of donating them. The ionization potential for the studied molecules group is greater than that for the original azulene molecule, but the molecule No.6 has the largest value of ionization potential, this indicates that this molecule needs high energy to become cation comparing with the others. The strength of an acceptor molecule is measured by its electron affinity (EA) which the energy released when adding one electron to LUMO. An acceptor must have a high EA, adding the CN radical to the ring leads to increasing the ability of the electron affinity for the molecule, EA for molecule 6 is the largest, as we see in Table 1.

Few interesting observations have been made from the results that are shown in table 2 obtained through the energy-vertical method. The electron affinities (EA) computed from the energy of the lowest unoccupied molecular orbital (LUMO) are higher for all studied molecules than that of the energy-vertical method. The ionization potential (IP) that results from the highest occupied molecular orbital is smaller for all studied molecules than that of the energy-vertical method. From the previous investigations, it has been found that for almost all the commonly used exchange-correlation functional such as B3LYP, B3PW91, Koopman's theorem is not satisfied accurately [30]. The two results obtained by the calculation of electronegativities and electrophilicities also agreed very well with the difference in the result. This could be the reason for the low hardness values obtained from the orbital-vertical method than from the method of energy-vertical. Koopman's theorem neglects the relaxation effect by using the frozen-orbital approximation. However, this error is frequently compensated by the oppositely directed error due to the electron correlation effect, neglected in the Hartree-Fock (HF) method. Therefore, the Koopmans' theorem is a crude but useful and fast approach [38]. The behavior of electronegativity, softness and electrophilic index for the studied molecules shows the magnitude larger than these for the original ring, adding the radicals give the molecule more softness. The results in table. 2 are due to adiabatic method.

**Table2: The electronic properties for molecules.**

Molecules	IP(eV)	EA(eV)	X (eV)	H(eV)	S(eV) <sup>-1</sup>	W(eV)
1	4.375	1.240	2.807	1.862	0.300	3.853
2	4.675	1.993	3.334	1.749	0.285	4.004
3	5.295	2.054	4.484	1.620	0.308	4.064
4	4.225	1.916	3.886	1.521	0.435	3.856
5	5.053	3.104	4.266	1.334	0.825	4.025
6	6.135	3.854	4.994	1.042	2.206	5.345

The molecules dipole moment represents a generalized measure of bond properties and charge densities in a molecule [30]. Molecule with electron acceptor group due to better charge distribution and increasing distance have higher dipole moment[32], from table 3 molecule **2** has higher dipole moment (8.204 Debye) .

The results of the calculated polarizability for (**1** – **6**) molecules in table 3 showed that all substitution groups leads to increase the average polarizability and cause more reactive than the original molecule. The molecules **2** and **3** have average dipole polarizability equal 203.947 and 207.516 a.u, they have the highest polarizability and have highest reactivity. This due to the ring delocalizing  $\pi$  electron resonance from the ring groups [32].

**Table 3:calculated dipole moment  $\mu$ (Debye) and average polarizability  $\langle \alpha \rangle$  in atomic units for molecules.**

molecules	$\mu$	$\alpha_{zz}$	$\alpha_{yy}$	$\alpha_{xx}$	$\langle \alpha \rangle$
1	0.001	269.81	151.363	44.964	155.379
2	8.204	362.363	182.565	68.913	203.947
3	0.003	379.652	185.604	57.292	207.516
4	0.204	304.58	218.748	59.763	194.364
5	0.012	281.341	203.679	76.989	167.003
6	3.234	303.656	216.695	66.582	195.644

### III. IR Spectra

The IR spectra of (**1** - **6**) molecules are provided in fig. (2). The harmonic vibrational frequencies calculated for studied molecules at B3LYP level using the 6-31(d,p) basis sets. The (C – H) stretching vibrations of aromatic molecules in the region (2900 – 3250) cm<sup>-1</sup> which is characteristic region for ready identification of (C – H) stretching vibrations and particularly the region (3250 – 3100) cm<sup>-1</sup> for asymmetric stretching and (3100 – 2900) cm<sup>-1</sup> for symmetric stretching modes of vibration [30]. We summarized the vibrational frequencies and the corresponding intensities for cyano-azulene molecules group in fig. 2.

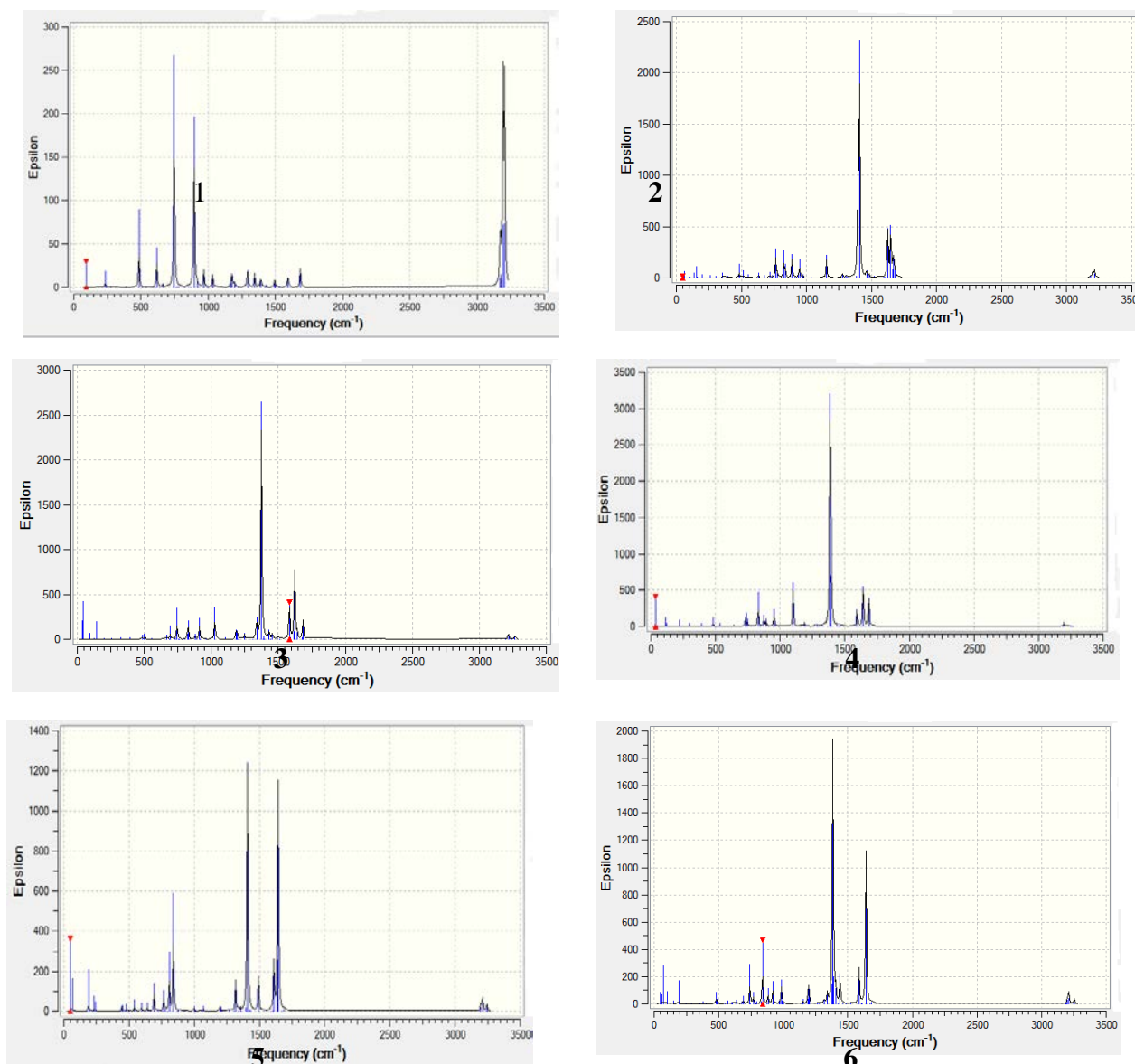

Figure 2: The IR spectra of molecules under study,  $\text{Epsilon} \equiv \text{Intensity (Km/mol)}$ .

#### IV. Conclusions:

The total energies for molecules under study are smaller than that for the original azulene molecule and substitution cyano group causes decreasing energy and more stability. The presence of the substituents decreases the energy gap of the studied molecules, this is one of the important properties obtained in this work, and a small energy gap means small excitation energies of manifold of the excited states. The electronic properties were calculated by two methods, energy-vertical method and orbital-vertical method and Koopman's theorem is not satisfied accurately. The results showed that all substitution groups leads to increase the average polarizability and dipole moment and cause to more reactive than original molecule. Adding the cyano groups leads to increasing the vibrational mode, and highest stretching vibrational wave numbers and its gave suitable positions for CN with carbon atoms in phenyl ring. Molecule **6** is the best option for n-type organic semiconductors because of its better HOMO – LUMO ratio and other electronic properties.



**References:**

- [1] K. J. Denniston, J. Topping and T. M. Dwyer, "General Organic and Biochemistry", 5<sup>th</sup> Edition, Towson University, 2007.
- [2] K. KefaOnchoke, M. Christopher /Hadad, and K. PrabirDutta, *J.Phys. Chem. A* 110 (2006)76-84.
- [3] O. Kwon, V. Coropceanu, N. E. Gruhn, J. C. Durivage, J. G. Laquindanum, H. E. Katz, J. Cornil, and J. L. Bredas, *J. Chem. Phys.*, 120(2004)8186.
- [4] H. Geng, Y. Niu, Q. Peng, Z. Shuai, V. Coropceanu, and Jean-Luc Bredas, *J. Chem. Phys.* 135. (2011)104703.
- [5] J. R. Sheats, H. Antoniadis, M. hueschen, W. Leonard, J. Miller, R. Moon, D. Roitman and A. Stocking, *science*, 273(1996)884.
- [6] F. Garnier, R. Hajlaoui, A. Yassar, P. Srivastava, *Science*, 265, 1648, 1994.
- [7] G. Horowitz, D. Fichou, X. Z. Peng, Z. G. Xu, F. Gamier, *Solid State Commun*, 72(1989)381.
- [8] G. Horowitz, *Adv. Mater*, 10(1998)365.
- [9] H. E. Katz, A. J. Lovinger, J. Johnson, C. Kloc, T. Siegrist, W. Li, Y. Y. Lin, A. Dodabalapur, *Nature (London)*, 404 (2000)478.
- [10] G. Yu, J. Wang, J. McElvain, A. Heeger, *Adv. Mater*, 10 (1998)1431.
- [11] C. J. Brabec, N. S. Sariciftci, J. C. Hummelen, *Adv. Funct. Mater*, 11 (2001)15. [12] H. E. Katz, *J. Mater. Chem*, 7(1997) 369.
- [13] H. Klauk, D. J. Gundlach, M. Bonsel, C. C. Kuo, T. Jackson, *Appl. Phys. Lett*, 76(2000)1692.
- [14] T. W. Kelley, D. V. Muyres, P. F. Baude, T. P. Smith, T. P. Jones, *Mater. Res. Soc. Symp. Proc*, 717(2003) 169.
- [15] M. D. Curtis, J. Cao, J. W. Kampf, *J. Am. Chem. Soc*, 126(2004)4318.
- [16] S. E. Koh, C. Risko, D. A. de Silva Filho, O. Kwon, A. Facchefti, J. L. Bredas, T. J. Marks, M. A. Ratner, *Adv. Funct. Mater*, 18(2008)332
- [17] G. R. Hutchison, M. A. Ratner, T. J. Marks, *J. Am. Chem. Soc.*, 127, 2339, 2005.
- [18] R. G. Parr, W. Yang, "Density- Functional Theory of Atoms and Molecules", Oxford University Press: New York, 1989.
- [19] M. A. De Oliveira, H. F. De Almeida, In. *J. Quan. Chem*, 90(2002)603.
- [20] Y. H. Park, Yun-Hi Kim, I. Sun Koo, and K. Yang, *Bull. Korean Chem. Soc.*, Vol.31, (2010) 1649 – 1656.
- [21] M. J. Frisch, G. W. Trucks, H. B. Schlegel et al., *Gaussian 09, Revision A.02*, Gaussian, Inc., PA, Wallingford CT. 2009.
- [22] C. Lee, W. Yang, R.G. Parr, *Phys. Rev. B* 37 (1988) 785.
- [23] A.D. Becke, *Phys. Rev. A* 38 (1988) 3098.
- [24] A.D. Becke, *J. Chem. Phys.* 98 (1993) 5648.
- [25] J. Engelberts, R. Havenith, J. Van Lenthe, L. Jenneskens, P. Fowler, *Inorg. Chem*, 44(2005) 52266.
- [26] J. C. Santos, W. Tiznado, R. Contreras, P. Fuentealba, *J. Chem. Phys.*, 120(2004)1670.
- [27] J. C. Santos, J. Andres, A. Aizman, P. Fuentealba, *J. Chem. Theory Comput*, 1(2005)83.
- [28] P. Udhayakala, T. V. Rajendiran, S. Seshadri, and S. Gunasekaran, *J. Chem. Pharm. Res.*, 3 (2011)610-625.
- [29] S. Gümüs, *Turk. J. Chem.*, 35(2011) 803-808.
- [30] K. Sadasivam, R. Kumaresan, *Computational and Theoretical Chemistry* 963 (2011) 227-235.
- [31] A. Demetrio Da Silva, V. Coropceanu, D. Fichou et al., *Phil. Trans. R. Soc. A*, 365 (2007) 1435- 1452.

- [32] M. Oftadeh, S. Naseh, M. Hamadianian, *Computational and Theoretical Chemistry* 966 (2011) 20-25.
- [33] N. Ketkar et al., *J. Mol. Struct.* 77(1981) 127.
- [34] P. Ravi, G. M. Gory, S. P. Tewari, and A. K. Sikder, *Journal of Energetic Materials*, 29 (2011) 209-227.
- [35] X. Ming-Hua, SU Ning-Hai, S. WU, *Chinese J. Struct. Chem.*, 27 (2008) 421-425.
- [36] Z. Wang, S.WU, *J.Serb. Chem. Soc.* 73 (2008) 1187-1196.
- [37] A.V. Kuhta, I. N.K. Kuhta, N. A. Kuhta, O. L. Neyra, E. Meza, *J. Phys. B: At. Mol. Opt. Phys.* 41 (2008) 205701.
- [38] U. Salzner, J. B. Lagowski, P.G. Pickup, and R. A. Poirier, *J. Comput. Chem.* 18 (1997)1934.
- [39] A. L. Mattiode, D. M. Hudgins, C. W. Bauschlicher Jr. L. J. Allamandola, *Advances in Space Reseaich*, 36 (2005) 156 – 165.