

# MULTI-PORT ELECTRIC STIMULATION SYSTEM USING HIGH SPEED PROCESSORS

*Lopez de la Fuente*

*Martha Salome, PhD*

University of Monterrey, Mexico

---

## Abstract

Electric signals are used in research areas as stimulus in tests: in body fluid samples to find a specific type of cells, particles, viruses or bacteria, in water samples to find pollutant agents, in blood samples to count T-Lymphocytes as cancer evidence, in food samples to determine safety, in prosthetics development for functional tests, in biotechnology to determine cell development stage, and several other fields. Currently, generic equipment such as standard signal generators is used to deliver the needed electric signals to the experimental setting. Generic equipment requires knowledge in the electric field, that researchers in biological and medicine fields do not have. Besides, it is expensive and delivers a limited type of signal waveforms. This paper presents the idea, design, implementation, and results of a flexible, programmable, multi-purpose device for delivering multi-waveform signals for a variety of applications. The idea is to develop a device which delivers different waveforms, single or superimposed, to several ports, where signal parameters such as amplitude, frequency, phase, waveform and repetition pattern are defined by the user. The design is based on a high speed processor, a Harvard architecture memory, a communication/configuration port, and 8-bit IO ports. A prototype is developed using an ARM processor based board, a C++ application program, and a User Interface. Specifications achieved: self contained, configurable, programmable, Vout up to 200Vpp, frequency 1Hz-40kHz, 4 waveforms (sinusoid, triangle, square, and saw-tooth), single, dual, or superimposed signals, waveform combination, single triggered outputs, continuous execution, and programmable repetition patterns.

---

**Keywords:** Embedded systems, electric stimulation, particle manipulation

## Introduction:

There is a need for reliable, portable, low cost devices, which can be used in research and experiments that require electric stimulation. Clinic analysis, water quality, food quality, genetic analysis, prosthetics, cancer research, cell differentiation and characterization, are research fields that can be beneficiated by this device. Research experimentation and testing require multiple repetitive stimulation varying parameters that may produce different effects or to prove that an experiment is developing as expected. A variety of signals, patterns and stimulation is needed, and existing equipment is of little use for researchers. Besides, biologists, medical staff, and doctors do not have the knowledge in electric, electronics and programming to operate or configure standard equipment, so their research advance and results slow down and depend on other people. The system detailed in this paper presents a portable, inexpensive device, that can be configured and operated easily, and provides any signal and pattern a researcher may need, by varying a few parameters and by connecting easily to any experimental setting. This way, a multi-purpose stimulation device is achieved, resulting in a configurable, programmable, and autonomous system. It can easily be modified to extend its use to other areas, by adding modular programming or including signal patterns

that do not follow a known behavior. The device software and user interface can be installed in any portable computer, and data can be stored from past experiments for future reference. A simple User Interface allows the researcher to set up, change and repeat experiments by changing the signal parameters. An infinite combination of signal patterns and stimulation can be achieved by varying amplitude, frequency, waveform, and repetition periods. This paper shows the system design and functionality, and a brief background of the application areas.

### Background on electric stimulation

The use of electric stimulation in several research areas is well documented; for example, small voltage signals are used in clinic analysis when looking for virus and bacteria in blood and urine; dielectrophoresis (DEP) is the phenomenon used for manipulating and separating dielectric particles and cells by suspending them in a fluid and using electric stimulation to generate electric fields in between, producing a controlled motion on the particles; in water and food freshness, samples are electrically stimulated to separate, count and extract pollutant agents; in flowing liquids, separation and filtration of undesired particles is produced by energized electrodes with electric stimulation of a specific frequency and phase. This research and analysis require reliable stimulation and experiment repeatability, in a way that precise and consistent results can be obtained, and used for further analysis.

In recent years, new applications for electric stimulation have been emerging: sinusoid waveforms are used to manipulate the DNA chain, electric signals are used to manipulate Cytotoxin in T-Lymphocytes, which are indicators of toxicity or cancer, and so on.

The proposed idea and implemented prototype, shown in this paper, may lead to a multi-application portable device which can deliver electric stimulation to a wide variety of research areas. Also, the prototype can obtain and store data related to the experimentation results, so it can be further analyzed to understand research results. Currently, most of the research and experimentation work is done with standard signal generators, setting operation parameters manually, by researchers with no background on electronics, all of which lead to slow, imprecise, not repeatable experimentation.

Examples of applications and the electric stimulation they use, are shown in Table 1.

Table 1. Ongoing research based on electric stimulation	
Application	Electric stimulation
Route different particles in one fluid sample	Sinusoidal, 200Hz, 100Vpp
Detect and manipulate pollutant particles in water	5 to 500KHz, 150Vpp
Manipulate poly-styrene testing beads	Sinusoidal, 1Khz-5MHz
Trap and sort proteins in DNA	2 opposite sinusoids, 8Vpp, 1MHz
Detect virus and cells in blood samples.	2 phased sinusoids, 10V, in the range of KHz
Separate and count T cells in blood for HIV diagnose	Sinusoidal, 6Vpp @ 50KHz
Separate red blood cells from other cells	Superimposed frequencies, phased sinusoids, 6Vpp, 200KHz
Manipulate and separate MD23 cancer cells	Sinusoidal, 10Vpp, 50KHz
Manipulation of pathogens in body fluids	Sine, 10V, 1 MHz AC/DC

**System design.** The idea of an autonomous system begins with a high speed processor that can run an application program fast enough to deliver continuous voltage samples that can be converted into a cyclic waveform. Tables in memory can contain the data samples that represent different waveforms. Efficiency in memory storage size can be achieved by storing only a fraction of a waveform, when possible, for example on sinusoids:  $\frac{1}{4}$  of the cycle contains the same information as the other  $\frac{3}{4}$ s. Output ports can be digital 8-bit IO, since 256 values scale is enough for up to 1mV steps. Digital to analog converters and analog filters are connected to the digital IO ports to convert the data samples into a continuous voltage signal. A cyclic execution of the application program produces a continuous sinusoidal signal. Different waveforms, not considered in the mentioned basic 4, can easily be added to the system by sampling a full period of the desired signal and representing it as a table of data

samples. The number of data samples used to construct any waveform does not need to be the complete set of samples stored in the memory tables: as fewer samples are used, higher frequencies can be achieved since it takes less execution time for the processor to go from the first through the last point. A user interface allows selecting configuration and operation parameters. Open source code can be modified to add functionality or new waveforms.

This stimulation system can be used as an autonomous component or as part of a LoC (Lab-on-Chip) design, when miniaturized. The complete system is shown in Figure 1: the User Interface allows parameter and operation configuration, the Electrical Stimulation System Prototype delivers digital data according to the selected configuration, the Signal Processing module converts the digital data into analog signals, the Experiment Setup contains the device to be stimulated, and the Monitoring and Feedback line carries information sensed in the experiment to determine adjustments in the stimulation. The Experiment Setup module depends on the research area, for example on particle manipulation it can be a video microscope to see the manipulation effects; in prosthetics testing it can be a prototype being stimulated to observe the mechanical response, and so on. Every block modules require minimum or no changes when migrating from one research area to another.

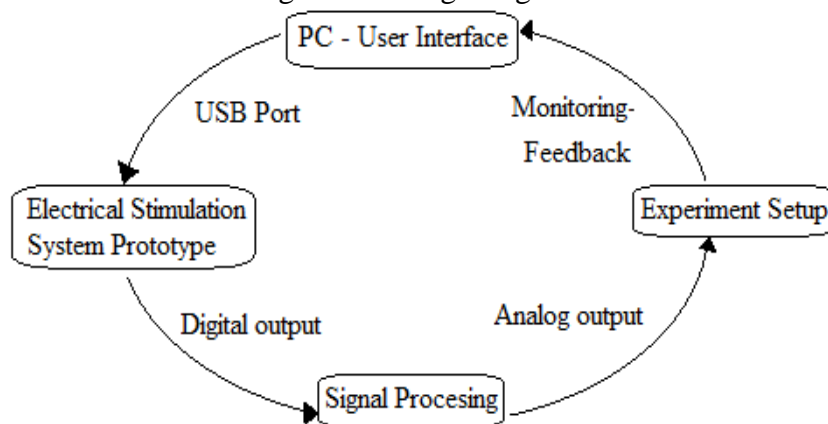

Figure 1. Block diagram of a complete Stimulation System

The application software, that delivers the output digital data to form the stimulation patterns, was developed in C++ and runs on an ARM processor based development board. The application program is stored in an EEPROM and a RAM array stores the waveform samples and the temporary data generated during execution of experiment. The system includes a USB or RS232 port for programming and configuration, and parallel ports are used as four 8-bit GPIO (General Purpose Input Output).

The application software architecture can be summarized as follows:

Set-up: Accept user parameters to define execution and signal generation scheme.

Select signal outputs: Determine, based on user parameters, the data tables, timing, and data separation to be used in signal generation.

Configure operation: Determine algorithm to construct the data table to be used for signal output.

Memory data tables: Use base data tables to extract samples for 1 or 2 separate signals; use base data tables to construct temporary data table for operation mode 3 (superposition of 2 signals).

Waveform superposition. A special case of signal generation occurs when a user needs to mix 2 different waveforms and frequencies to produce a unique output signal. This is useful when 2 different motion or manipulation effects are desired at the same time, over the same sample or device. A timed mix of data samples has to be achieved and stored in a temporary memory table, before signal generation occurs, so execution time is only used for output delivering but not for signal building. Figure 4 explains the way a 2-waveform, 2-frequency signal is achieved from base data tables, and stored into the temporary table.

The hardware architecture is represented in Figure 2.

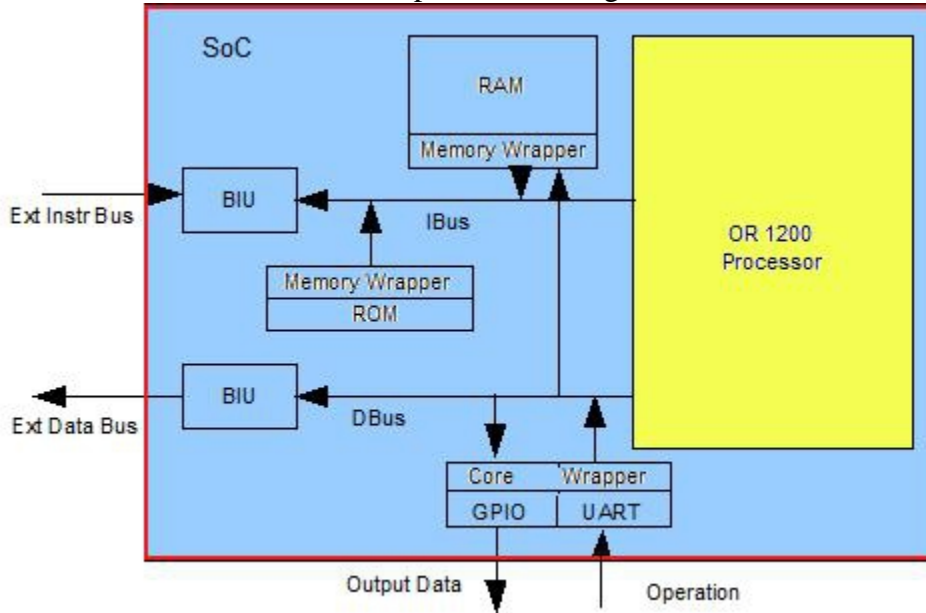

Figure 2. Hardware architecture of the Electric stimulation system.

Processor: executes the application program using maximum crystal frequency to achieve maximum frequency in the output signals.

Application program memory. Several programs were tested, mainly evaluating 2 schemes: Memory intensive versus Computation intensive. The core of the memory intensive scheme is the use of data tables containing the sampled waveforms. The core of the computation intensive scheme uses Taylor series to calculate up to 4 decimals the value of the signal samples; more decimals were not needed due to the effect of the external filter. Figure 3 shows both. The selection, for maximum output frequency, was Memory intensive scheme.

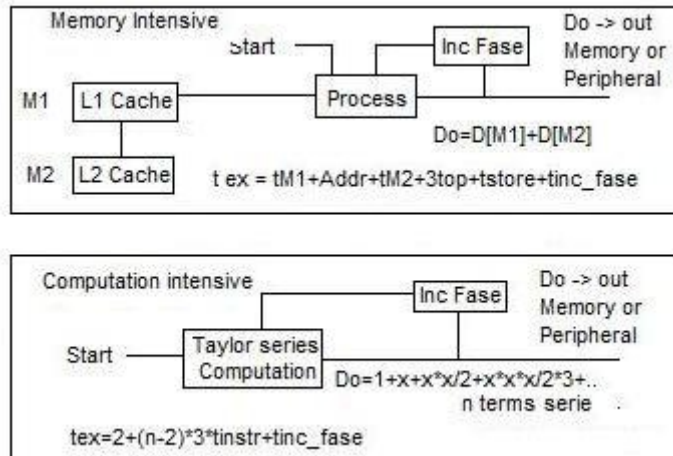

Figure 3. Memory intensive versus Computation intensive.

Data memory. Contains 2 types of data tables: the permanent tables containing waveform samples used to construct and deliver the signal for all the operation modes, and the temporary tables calculated prior to execution of operation mode 3, because the superposition of 2 signals has to be calculated before in order to not to take time for it when delivering the signal. This is the key to obtain maximum frequency output even when superimposing 2 signals with very different frequencies. This procedure is shown in Figure 4.

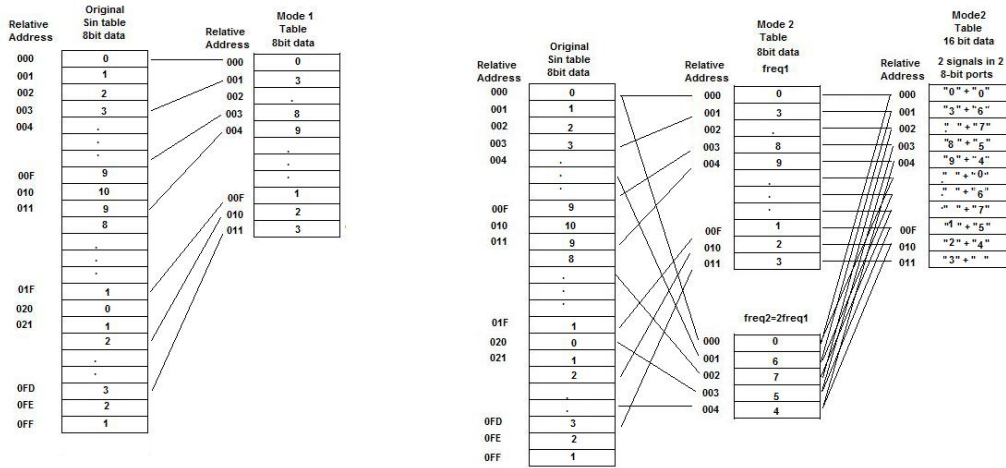

Figure 4. Data table construction for 1 and 2 signals.

**IO Port.** Two 8-bit IO ports are used to deliver digital data to external Digital to Analog Converter (DAC) and then to analog filter. 8 bit ports allow internal data tables of 256 data values for signal samples.

**Communication port.** A USB port is used for programming, operation, and configuration of the prototype. Programming allows adding future additions to the current application program; operation allows using a regular personal computer to install the development software and the user interface; and configuration allows executing the program under selected parameters via the same computer or as a standalone module.

**Open source code.** When needed, open source libraries were used in order to keep a low cost on the prototype.

**Signal conditioning.** As the processor based system delivers digital signals, a digital to analog conversion, filtering, and in some cases amplification, is needed as an external circuit. All tests were successfully completed for the signal parameters intended in this work.

The interface shown in Figure 5 allows the user to easily select and define the parameters for the operation.

```

Signal GenerationSystem
Configuration and Operation
*****
*****
Run program as
    1)Time based run
    2) Variable pattern run, timed
    3)Frequency sweep
*****
*****
Select Operation mode
    1)Single Frequency
    2)Dual Separated Frequencies
    3)Dual Superimposed Frequencies
*****
*****
Select Signal Output Type
    1)Sinusoidal
    2)Triangle
    3)Square
    4)Sawtooth
Frequency for Signal 1 (Hertz):
Frequency range if sweeping (Hertz):
Number of samples per Cycle:
*****
*****
Select Signal Output Type 2 (for Op. Mode 2 or 3):
    1)Sine Waveform
    2)Triangle Waveform
    3)Square Waveform
    4)Sawtooth Waveform
Frequency for Signal 2 (Hertz):
Number of samples per Cycle:
ENTER for System to run
    
```

Figure 5. User Interface: to configure and operate the signal generator.

First, to select if the signal will be delivered by a finite amount of time, if the waveform should change automatically during execution, or to make a sweep over a frequency range. Then, to set the operation mode: select a single signal, or 2 signals over 2 different output channels, or 2 different signals superimposed to deliver on 1 single output. Then to set the type of waveform, the frequency, and the data samples per signal cycle. The amount of samples per cycle impacts the maximum achievable frequency, so small numbers are recommended for high frequencies. Last, for operation modes 2 and 3, parameters for the 2<sup>nd</sup> signal are set. No signal delivery occurs until all the parameters are set and the final Enter is typed; this is due to the importance of the timing in certain experiments.

**Functional specifications.** The prototype has been tested in different development boards from several commercial brands, so its portability is fully demonstrated: it runs on a LM3S6965 Luminary micro board, on a Tower system from Freescale, a Kinetis Quickstik from Freescale, and on an Arduino II. The best performance has been achieved by the ARM processor based boards, as they are intended for real time applications. If system is transferred to a board other than the mentioned, full frequency range can be achieved by a processor running on a 50 MHz or higher clock, an a program memory of at least 256 kB, data SRAM of 64kB or more, and two 8-bit General purpose IO. A USB port is highly recommended since it provides input for in-field programming and configuration. If a battery or energy source is provided, the system can operate as an autonomous system. If long term storage is needed for data resulting from repeated experimentation, a personal computer attached to the system is recommended. After rounds of improvement in software and hardware, the functional specifications of this Electrical Stimulation prototype are shown on Table 2.

Table 2. Device specifications	
Waveforms	Sinusoidal, triangle, saw-tooth, and square
Frequency Range	1 Hz - 40 kHz
Data samples per signal cycle	From 8 to 256
Output amplitude	200Vpp
Output configurations	Single output, dual output, 2 dephased outupt. 2 separated waveforms, 2 superimposed waveforms
Output Types	Single, Dual, and Superimposed Output (whether using frequency sweep, or simple output mode)
Application software	Modular, generates waveforms, stores, repeat patterns
Hardware architecture	Stand-alone module, foundation for a lab-on-a-chip

The prototype was tested to show that it delivers the kind of signals mentioned above; results for the intended frequency range and waveforms were successfully achieved. Figure 6 shows the experimental setting and the stimulation system.



Figure 6. User interface, Prototype board, Signal viewer. Development board: The LM3S6965 prototyping a) ARM® Cortex-M3 Processor, b) GPIO, c) USB port, d) Reset, e) Memory card slot for data and/or program.

Examples of the waveforms obtained: Simple sinusoid, simple triangle, simple sawtooth, triangle superimposed over a sinusoid, sawtooth superimposed over a triangle, triangle superimposed over a sawtooth, and so on. Also, tests were conducted in order to ensure that different frequencies can be achieved during superposition, as it is shown in Figure 4. Different number of data samples were used in tests, to ensure waveform remain consistent regardless the amount of samples; this is achieved due to the external analog filter. These signals prove to be useful in the research areas mentioned in table I; the parameters achieved are 200Vpp maximum, of up to 40KHz. Ongoing work is in process to extend the frequency range in order to reach additional research areas. Figure 7 shows examples of the various patterns and superposition that can be delivered by the system.



Figure 7. Examples of the delivered signals, different waveforms, different frequencies.

**Future work.** As use of this system finds its way through on-going research areas, additional functionality will certainly arise. Audio systems and prosthetic devices use signal patterns very different from standard sinusoids and saw-tooth, and they can also be characterized and represented with data tables. Some areas require closing the experimentation loop by sensing a physical variable to further correct the stimulation signal; current system can receive input signals from any digital sensor, so its information can be integrated into the user selection when deciding the signal and operation parameters. Future work also includes breaking the dependence of the maximum frequency output from the processor clock speed, by adjusting the time between samples when mixing data samples from 2 or more different waveforms. An interesting addition is in progress: once a user finds the tests which are usually performed, the stimulation parameters can be saved in the system

for future use, so several tests can be saved as TestFreq1, TestFreq2, and so on; this way, the configuration and operation parameters can be saved and used later, to ensure that the exact same stimulation is used and can be compared to previous research results.

### Conclusion:

Experiment stimulation using electric signals is needed in several research areas. Generic equipment such as signal generator is available but do not fulfill the need for user configuration, programming, variety of waveform patterns, and operation. The prototype presented in this work delivers electric signals over a wide range of parameters, as an autonomous portable device. It can deliver any combination of different waveforms over up to 4 output channels. Open source software is provided for this application and it can run on different commercial hardware platforms. Future work on this prototype is in progress, to add new waveforms, deliver higher voltages, wider frequency range, and to integrate sensors for giving feedback to the system so it can auto-adjust signal outputs.

### References:

- M. Salome-Lopez, G. Andreas, A. Alfonso, S. O. Martinez-Chapa. “A programmable and configurable Multi-port System-on-Chip for stimulating Electrokinetically-driven Microfluidic Devices” International Conference of the IEEE Engineering in Medicine and Biology Society IEEE (EMBC 2011), Boston MA, USA, 2011
- Martha Salome Lopez, Blanca Lapizco-Encinas, Sergio Martinez Chapa, An electric stimulation system for electrokinetic particle manipulation in microfluidic devices, Review of Scientific Instruments Journal, USA, 2013.
- Martha S. Lopez, Jose A. Benavides, An electric stimulation system for research and testing, Electronics, Robotics and Automotive Mechanics Conference (CERMA, IEEE) México, 2012.
- M. Salome-Lopez Definition, Design, and Implementation of a Processor-Based Stimulation System for Electrokinetically-Driven Fluidic Devices, Instituto Tecnológico y de Estudios Superiores de Monterrey, México. 2011
- S. O. Chacón, B. H. Lapizco-Encinas, M. Rito-palomares, E. Collado-Arredondo, S.O. Martinez-Chapa. “Dielectroforesis con estructuras Aisladoras” Chemical Engineering Mexican Journal, Universidad Autónoma Metropolitana, Iztapalapa México, 2007. Vol. 6 (3)
- I. C. Young, A. F. Alexander. “Application of pulsed electrical field for advanced cooling and water recovery in coalfired power plant” U.S. Department of Energy, Drexel University, Chestnut St. Philadelphia, 2009.
- S. Tuukkanen, J.J. Toppari, A. Kuzyk, P. Törmä. “Dielectrophoresis as a tool for nanoscale DNA manipulation” International Journal of Nanotechnology, Jyväskylä, Finland. 2005, Vol. 2(3) pp. 280-291.
- K. Mehti, S. Park, D. P. Sureh, B. Alli. “Negative dielectrophoretic capture of bacterial spores in food matrices” Biomicrofluidics. American Institute of Physics. Norfolk Virginia, 2010
- M. Bocchi, E. Franchi, R. Guerrieri. “Electronic Microsystems for Handling Rare Cells” IEEE Journal & Magazines. 2010. Vol. 57(1):244-255.
- R. Jan, T. D. Thanh, E. Ralf, A. Dario, R. Alexandra. “Dielectrophoretic Manipulation of DNA: Separation and Polarizability” Analytical chemistry, Bielefeld University, Bielefeld Germany, 2007, Vol. 79(10), pp. 3925-3932.
- R. Hölzel, F.F. Bier “Dielectrophoretic manipulation of DNA” Journal IEEE Proc-Nanobiotechnol. 2003 Vol. 150(2)
- A.T. Giannitsis “Usage of a microfluidic lab-on-chip in biomedicine” 12th Biennial Baltic Electronica Conference, Tallin Technical University, Tallin Estonia. 2010.
- N. Pamme, “Continuous flow separations in microfluidic devices” Lab on a Chip, The University of Hall, Cottingham Road UK, 2007, Vol. 7(12) pp. 1644-1659.